

**Technical Information**

**General Description**

Spool Type , Normally Closed, Vent to Open Logic Element. For additional information see Technical Tips on pages LE1-LE6.

**Features**

- High flow capacity
- Can be used as high flow switching or metering element
- Can be used as main stage for a pilot operated relief or sequence valve
- Integral 250 micron pilot flow filter
- Various switching pressures available
- 1:1 pilot pressure ratio
- Hardened working parts for maximum durability
- All external parts zinc plated

**Performance Curve** (Through cartridge only)  
**Vented Open Pressure Drop vs. Flow 1 to 2**

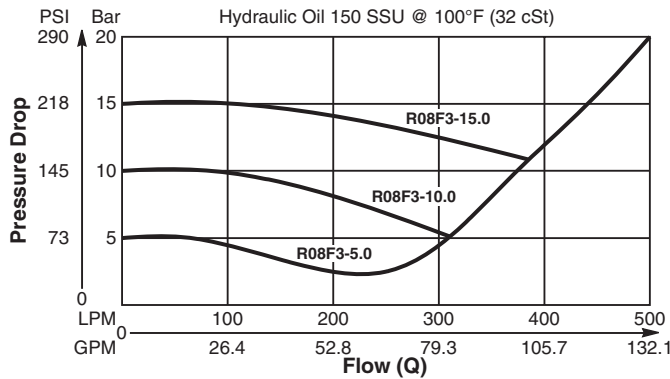

**Specifications**

<b>Rated Flow</b>	500 LPM (132 GPM)
<b>Nominal Flow @ 7 Bar (100 PSI)</b>	340 LPM (90 GPM)
<b>Maximum Inlet Pressure</b>	420 Bar (6000 PSI)
<b>Leakage @ 150 SSU (32 cst)</b>	90 ml/min. @ 100 Bar (1450 PSI)
<b>Switching Press.</b>	See ordering information
<b>Cartridge Material</b>	All parts steel. All operating parts hardened steel.
<b>Operating Temp. Range/Seals</b>	-34°C to +121°C (Nitrile) (-30°F to +250°F) -26°C to +204°C (Fluorocarbon) (-15°F to +400°F)
<b>Fluid Compatibility/Viscosity</b>	Mineral-based or synthetic with lubricating properties at viscosities of 45 to 2000 SSU (6 to 420 cSt)
<b>Filtration</b>	ISO-4406 18/16/13, SAE Class 4
<b>Approx. Weight</b>	.69 kg (1.52 lbs.)
<b>Cavity</b>	C20-3S (See BC Section for more details)
<b>Form Tool</b>	Rougher NFT20-3SR Finisher NFT20-3SF

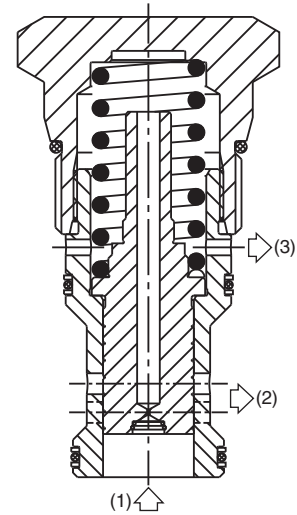
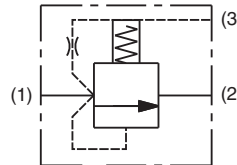
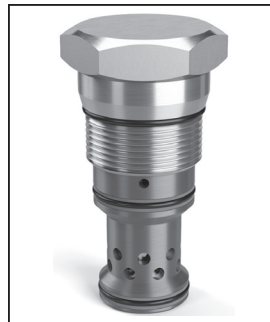

**Dimensions** Millimeters (Inches)

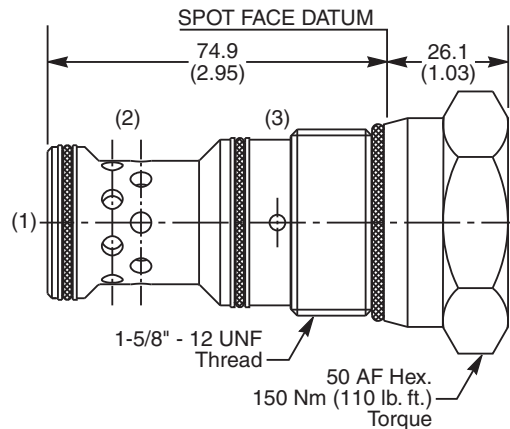

**Ordering Information**

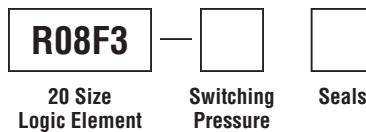

Code	Switching Pressure Non Adjustable Preset
5.0	5.0 Bar (73 PSI) Std.
10.0	10.0 Bar (145 PSI)
15.0	15.0 Bar (218 PSI)
20.0	20.0 Bar (290 PSI)

Code	Seals / Kit. No.
N	Nitrile, Buna-N (Std.) / (SK30512N-1)
V	Fluorocarbon / (SK30512V-1)

If no switching pressure is specified, valve will be supplied as R08E3-5.0N

- CV Check Valves
- SH Shuttle Valves
- LM Load/Motor Controls
- FC Flow Controls
- PC Pressure Controls
- LE Logic Elements
- DC Directional Controls
- MV Manual Valves
- SV Solenoid Valves
- PV Proportional Valves
- CE Coils & Electronics
- BC Bodies & Cavities
- TD Technical Data

