

Technical Information

- CV** Check Valves
- SH** Shuttle Valves
- LM** Load/Motor Controls
- FC** Flow Controls
- PC** Pressure Controls
- LE** Logic Elements
- DC** Directional Controls
- MV** Manual Valves
- SV** Solenoid Valves
- PV** Proportional Valves
- CE** Coils & Electronics
- BC** Bodies & Cavities
- TD** Technical Data

General Description

Needle Type, Pressure Compensated Flow Regulator Valve. For additional information see Technical Tips on pages FC1-FC4.

Features

- Good adjustment from 1-15 LPM (0.3-4 GPM)
- Used for systems requiring priority flow such as steering systems
- Hardened working parts for maximum durability
- Reverse flow function 3 to 1
- Adjustable and tamperproof versions available
- All external parts zinc plated

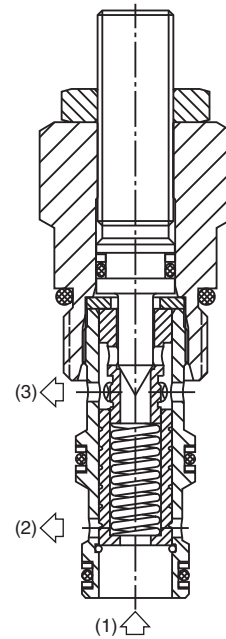
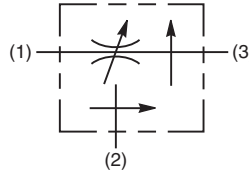
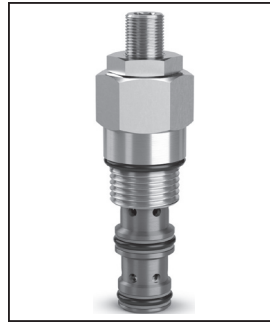

Specifications

Rated Flow	15 LPM (4 GPM)
Maximum Inlet Pressure	420 Bar (6000 PSI)
Cartridge Material	All parts steel. All operating parts hardened steel.
Operating Temp. Range/Seals	-34°C to +121°C (Nitrile) (-30°F to +250°F) -26°C to +204°C (Fluorocarbon) (-15°F to +400°F)
Fluid Compatibility/ Viscosity	Mineral-based or synthetic with lubricating properties at viscosities of 45 to 2000 SSU (6 to 420 cSt)
Filtration	ISO-4406 18/16/13, SAE Class 4
Approx. Weight	.08 kg (.18 lbs.)
Cavity	C08-3 (See BC Section for more details)
Form Tool	Rougher NFT08-3R Finisher NFT08-3F

Performance Curves (Through cartridge only)

Flow Regulating Performance

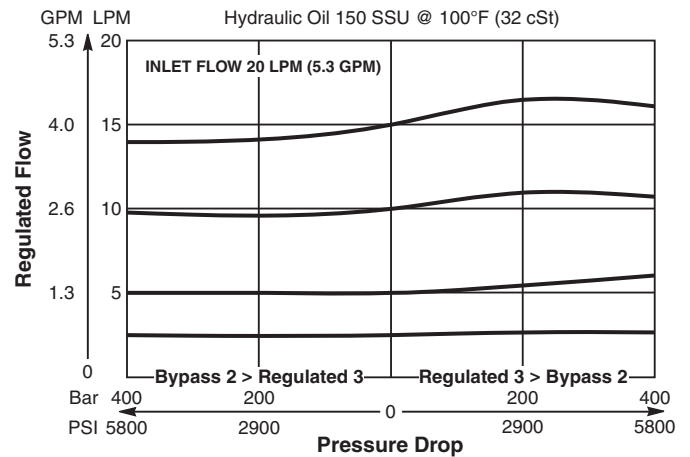

Application

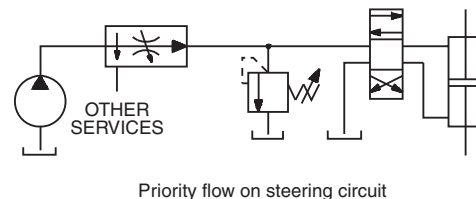

Dimensions Millimeters (Inches)

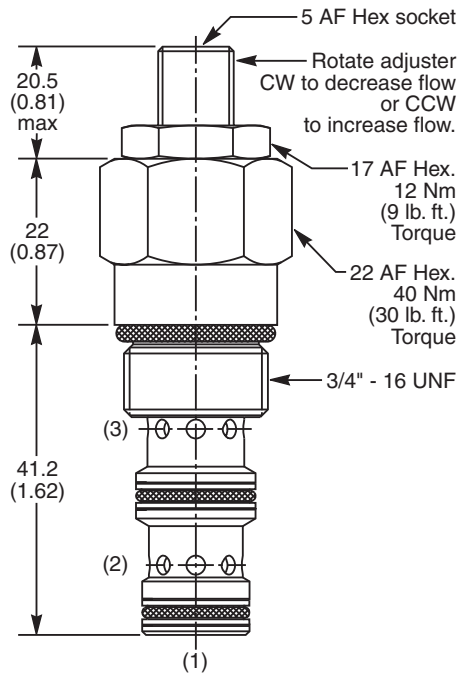

Ordering Information

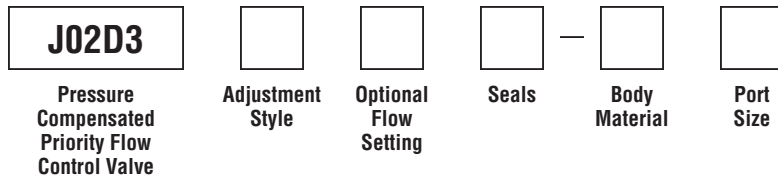

Code	Adjustment Style
Z	Screw Adjust (Std.)
W	Knob Adjust
T	Tamper Resistant Cap (TC1130)

Code	Seals / Kit. No.
N	Nitrile, Buna-N (Std.) / (SK30501N-1)
V	Fluorocarbon / (SK30501V-1)

Code	Body Material
Omit	Steel
A	Aluminum

Code	Port Size	Body Part No.
Omit	Cartridge Only	
4T	SAE-4	(B08-3-*4T)
6T	SAE-6	(B08-3-*6T)

* Add "A" for aluminum, omit for steel.

Code	Optional Flow Setting
Omit	Omit for no setting* Specify setting if required (LPM)

* Appropriate mid-range setting for Standard = 7 LPM

- CV**
Check Valves
- SH**
Shuttle Valves
- LM**
Load/Motor Controls
- FC**
Flow Controls
- PC**
Pressure Controls
- LE**
Logic Elements
- DC**
Directional Controls
- MV**
Manual Valves
- SV**
Solenoid Valves
- PV**
Proportional Valves
- CE**
Coils & Electronics
- BC**
Bodies & Cavities
- TD**
Technical Data