

General Description

Priority Type, Pressure Compensated Flow Regulator Valve.
 For additional information see Technical Tips on pages FC2-FC5.

Features

- High flow capacity
- Good adjustment from 2-45 LPM (0.5-12 GPM)
- Used for systems requiring priority flow such as steering systems
- Reverse flow function 3 to 1
- Hardened working parts for maximum durability
- All external parts zinc plated

Specifications

Rated Flow	70 LPM (18 GPM)
Maximum Regulated Flow	45 LPM (12 GPM)
Maximum Inlet Pressure	420 Bar (6000 PSI)
Cartridge Material	All parts steel. All operating parts hardened steel.
Operating Temp. Range/Seals	-34°C to +121°C (Nitrile) (-30°F to +250°F) -26°C to +204°C (Fluorocarbon) (-15°F to +400°F)
Fluid Compatibility/Viscosity	Mineral-based or synthetic with lubricating properties at viscosities of 45 to 2000 SSU (6 to 420 cSt)
Filtration	ISO-4406 18/16/13, SAE Class 4
Approx. Weight	0.18 kg (0.40 lbs.)
Cavity	C10-3 (See BC Section for more details)

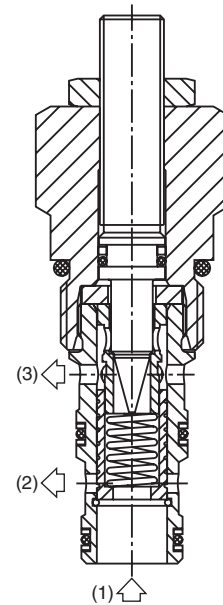
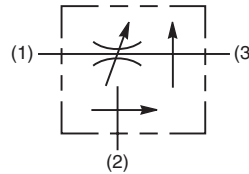

Performance Curves

Flow vs. Inlet Pressure (Through cartridge only)

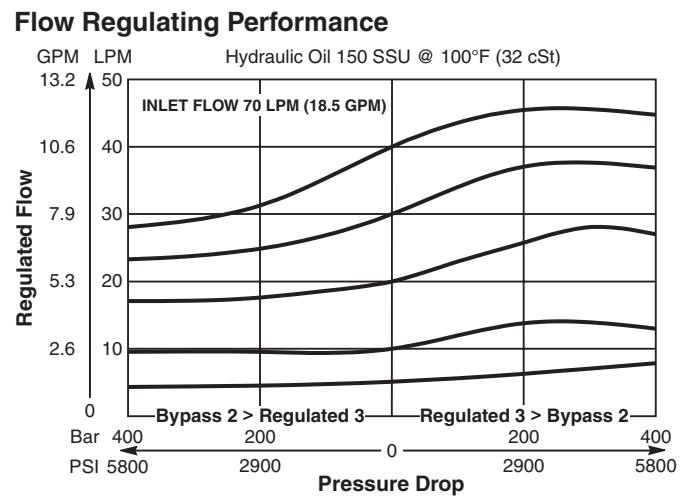

Application

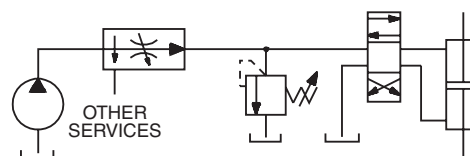

Priority flow on steering circuit

CV
Check Valves
SH
Shuttle Valves
LM
Load/Motor Controls
FC
Flow Controls
PC
Pressure Controls
LE
Logic Elements
DC
Directional Controls
SV
Solenoid Valves
PV
Proportional Valves
CE
Coils & Electronics
BC
Bodies & Cavities
TD
Technical Data

Dimensions Millimeters (Inches)

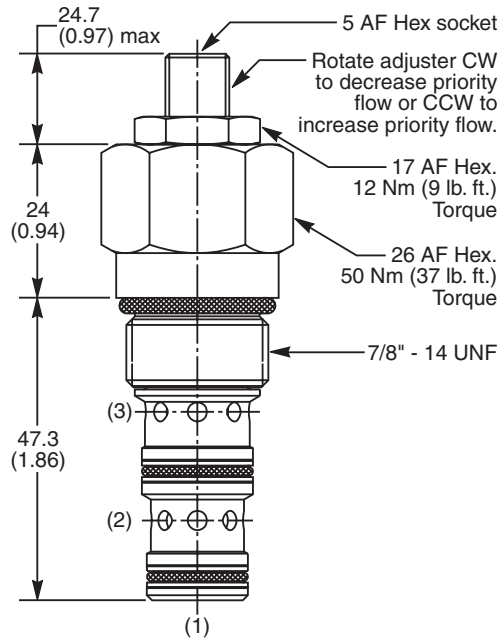

Ordering Information

J04D3	Z	N
Pressure Compensated Priority Flow Control Valve	Adjustment Style	Seals

Highlighted represents preferred options that offer the shortest lead times. Other options may be available, but at extended lead times.

Code	Adjustment Style
Z	Screw Adjust

Code	Seals
N	Nitrile

Standard valve has a flow setting of 20 LPM.

Kit	Part Number
Knob	ASV014975
Tamper Resistant Cap	TC1130
Nitrile Seal	SK30505N-1
Fluorocarbon Seal	SK30505V-1

Order Bodies Separately
 See section BC

B10	—	3	—	8T
10 size		3-Way Cavity		Port Size

Code	Porting / Body Material
8T	SAE-8 / Steel (5000 PSI)

CV
Check Valves
SH
Shuttle Valves
LM
Load/Motor Controls
FC
Flow Controls
PC
Pressure Controls
LE
Logic Elements
DC
Directional Controls
SV
Solenoid Valves
PV
Proportional Valves
CE
Coils & Electronics
BC
Bodies & Cavities
TD
Technical Data