

Valve/Cavity Compatibility

For additional information see Technical Tips on pages BC2-BC3.

		VALVE			
		Parker	Waterman	FPS	CEC
CAVITY	Parker	X	X		
	Waterman	X	X		
	FPS			X	X
	CEC			X	X

Performance Curve
Pressure Drop vs. Flow

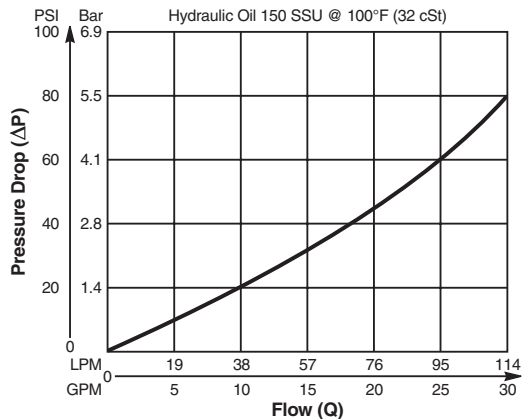

Dimensions Millimeters (Inches)

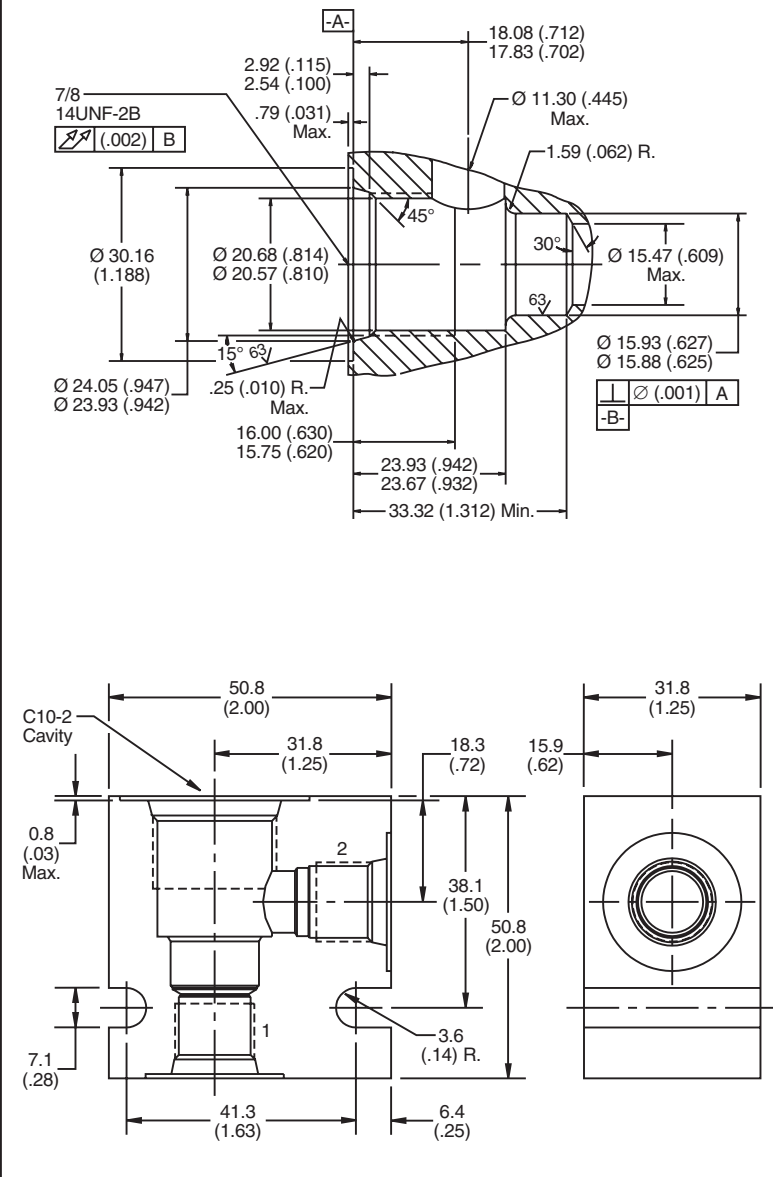

Ordering Information

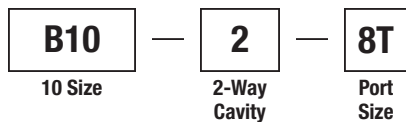

Code	Port Size
8T	SAE - 8/Steel (5000PSI)

Weight: .45 kg (1.0 lbs.)

- CV Check Valves
- SH Shuttle Valves
- LM Load/Motor Controls
- FC Flow Controls
- PC Pressure Controls
- LE Logic Elements
- DC Directional Controls
- SV Solenoid Valves
- PV Proportional Valves
- CE Coils & Electronics
- BC Bodies & Cavities
- TD Technical Data