



www.Parker.com/HydraulicValve

Colorflow[®] and Ball Valves

Industrial Flow Control, Check, Gauge Control

Catalog MSG14-3300/US

September 2022

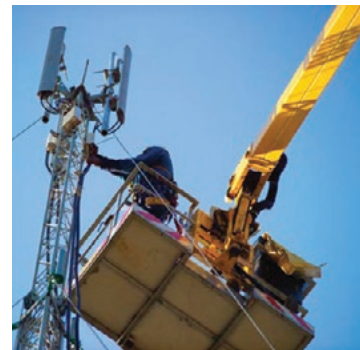

ENGINEERING YOUR SUCCESS.

Fully guided poppets are used on Colorflow valves rather than the less durable ball-check type construction. Poppets open and close more smoothly — last longer — and eliminate the distortion of seats and springs.

The exclusive “Colorflow” feature on metering, flow control, and needle valves gives highly visible check-points for setting valve openings. This feature also provides a reference point that allows the valve to be accurately and quickly reset to a previous setting.

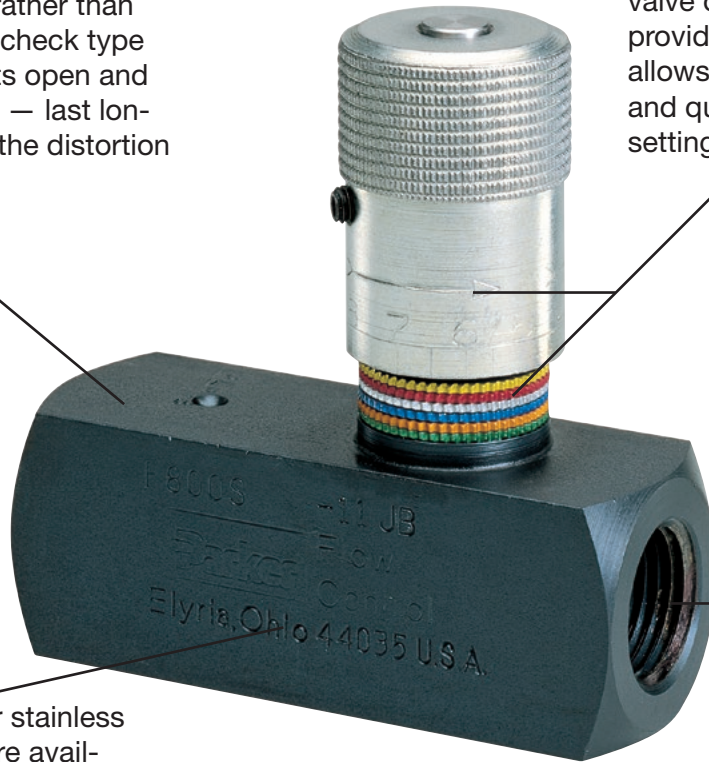

Steel, brass or stainless steel bodies are available, all of which include stainless steel needles as standard.

Colorflow valves are available with a variety of porting options.

WARNING: Colorflow valves are not repairable

⚠ WARNING – USER RESPONSIBILITY

FAILURE OR IMPROPER SELECTION OR IMPROPER USE OF THE PRODUCTS DESCRIBED HEREIN OR RELATED ITEMS CAN CAUSE DEATH, PERSONAL INJURY AND PROPERTY DAMAGE.

- This document and other information from Parker-Hannifin Corporation, its subsidiaries and authorized distributors provide product or system options for further investigation by users having technical expertise.
- The user, through its own analysis and testing, is solely responsible for making the final selection of the system and components and assuring that all performance, endurance, maintenance, safety and warning requirements of the application are met. The user must analyze all aspects of the application, follow applicable industry standards, and follow the information concerning the product in the current product catalog and in any other materials provided from Parker or its subsidiaries or authorized distributors.
- To the extent that Parker or its subsidiaries or authorized distributors provide component or system options based upon data or specifications provided by the user, the user is responsible for determining that such data and specifications are suitable and sufficient for all applications and reasonably foreseeable uses of the components or systems.

OFFER OF SALE

The items described in this document are hereby offered for sale by Parker-Hannifin Corporation, its subsidiaries or its authorized distributors. This offer and its acceptance are governed by the provisions stated in the detailed “Offer of Sale” elsewhere in this document or available at www.parker.com/hydraulicvalve.

SAFETY GUIDE

For safety information, see Safety Guide SG HY14-1000 at www.parker.com/safety or call 1-800-CParker.

© Copyright 2022, Parker Hannifin Corporation, All Rights Reserved

Contents

Colorflow® Valves

Page

Flow Control Valves

Series F Flow Controls 4 - 7

Series PC*K..... Pressure Compensated Flow Controls 8 - 10

Series PC*M Pressure Compensated Flow Controls, Adjustable 11 - 13

Series N..... Needle Valves..... 14 - 16

Series MV Metering Valves 17 - 20

Series MVI Cartridge-type Metering 21 - 23

Check Valves

Series C..... Check Valves..... 24 - 26

Gauge Control Valves

Series GF..... Gauge Isolator Valve 27

Series GT..... Push-to-Read Gauge Isolator Valve.....28

Ball Valves

High Pressure Ball Valves

Series BVHP2-Way, 500 Bar (7250 PSI)1/4"-1", in-line 30 - 46

Series BVAH2-Way, 500 Bar (7250 PSI)1/4"-2", in-line 30 - 46

Series BVHH.....2-Way, 800 Bar (11,600 PSI)1/2"-2", in-line 47 - 51

Series BV3D3-Way, 500 Bar (7250 PSI)1/4"-2", in-line 52 - 57

Series BV3H3-Way, 500 Bar (7250 PSI)1/4"-2", in-line 58 - 61

Series BV4H4-Way, 500 Bar (7250 PSI)1/4"-2", in-line 58 - 61

Series BVMM.....2 and 3-Way, 500 Bar (7250 PSI)1/4"-2", manifold 62 - 67

Series BVSL2-Way, 100 Bar (1450 PSI)1/4"-4", aluminum-suction 68 - 73

Technical Appendix 74 - 75

Terms of Sale with Warranty Limitations.....77

Safety Guide..... 78 - 81





**Check, Flow Control,
Metering, Needle, and
Gauge Control Valves**

Colorflow[®] Valves



ENGINEERING YOUR SUCCESS.

General Description

Series F flow control valves provide precise control of flow and shut-off in one direction, and automatically permit full flow in the opposite direction.

Operation

A two-step needle allows fine adjustment at low flow by using the first three turns of the adjusting knob. The next three turns open the valve to full flow, and also provide standard throttling adjustments.

Features

- The exclusive “Colorflow” color-band reference scale on the valve stem is a great convenience and time-saver in setting the valve originally and in returning it to any previous setting.
- A simple set screw locks the valve on any desired setting.
- A tamperproof option (T) feature is also available to prevent accidental or intentional adjustment of flow setting.

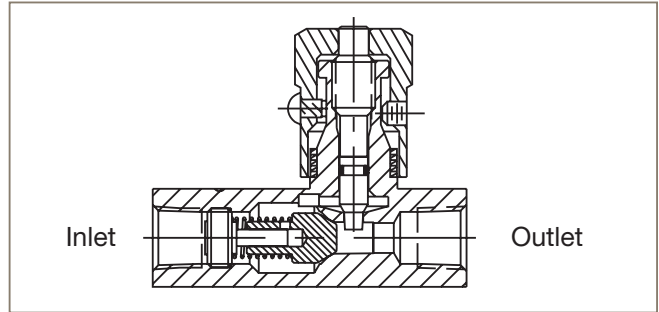
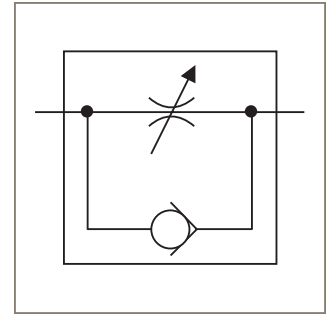

Specifications

Maximum Operating Pressure	Brass: 140 Bar (2000 PSI); except for F1600 brass which is 35 Bar (500 PSI) Steel & Stainless Steel: 350 Bar (5000 PSI) for 200 thru 800 & 420 thru 1220; 210 Bar (3000 PSI) for 1200 thru 3200 & 1600 thru 3220	
Material	Body: Steel, Brass, or 303 Stainless Steel Knob: Steel - Zinc plated Spring: 302 Stainless Steel	Poppet: 416 Stainless Steel Retainer: 416 Stainless Steel Needle: 416 Stainless Steel
Poppets	Soft seal poppet in brass 200 - 820 sizes Solid metal 416 stainless steel poppet on all other sizes and styles	
Nominal Cracking Pressure	0.4 Bar (5 PSI) standard	
Temperature Range of Seal Compound	-40°C to +121°C (-40°F to +250°F) Nitrile (standard) -26°C to +205°C (-15°F to +400°F) Fluorocarbon	

WARNING: This product can expose you to chemicals including Lead, Nickel (Metallic), or 1,3-Butadiene which are known to the State of California to cause cancer, and Lead or 1,3-Butadiene which is known to the State of California to cause birth defects and other reproductive harm. For more information go to www.P65Warnings.ca.gov.

Cat3300.indd, ddp, 09/22



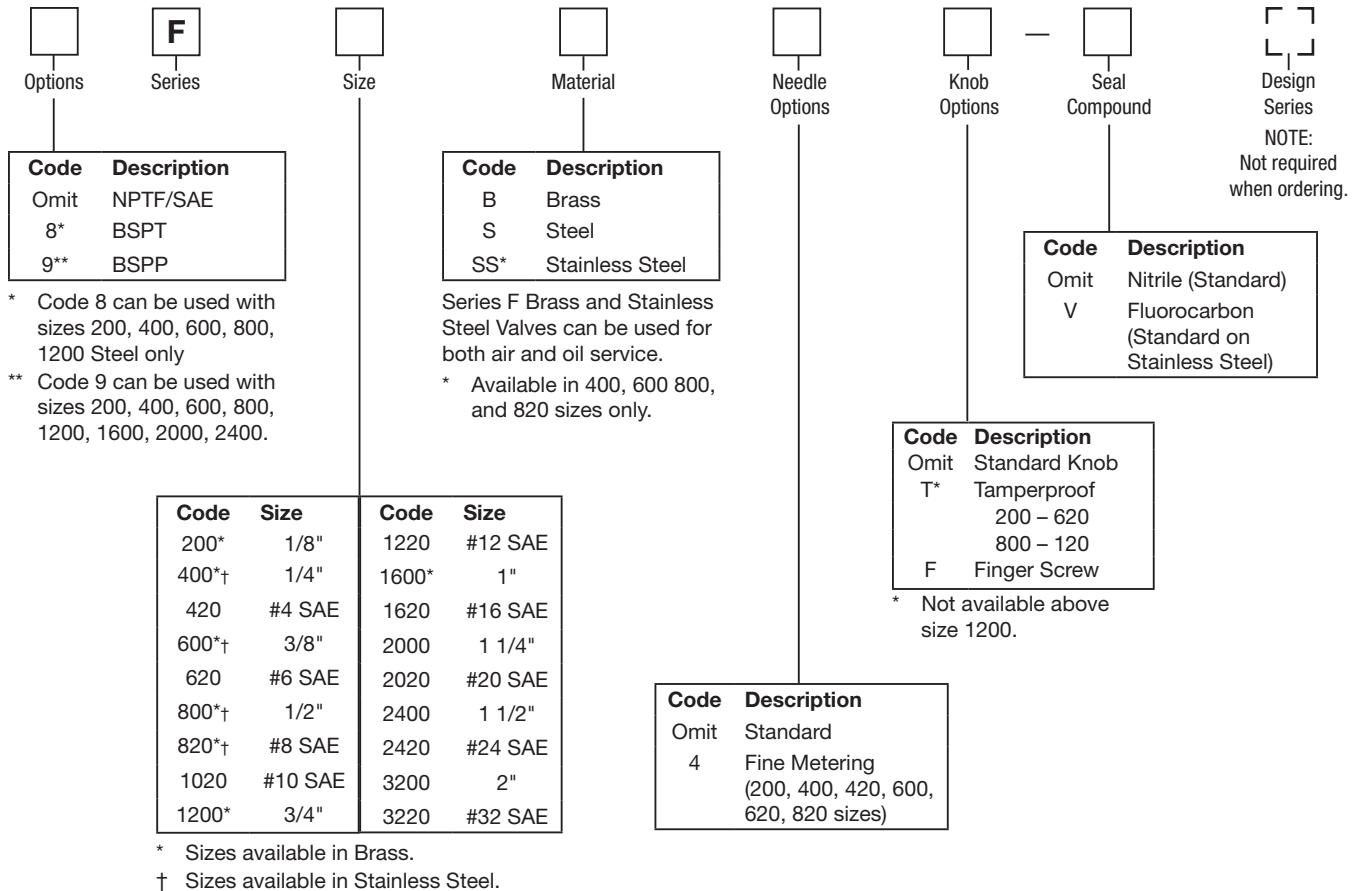

Model Number	Free Flow Rate, Max. LPM (GPM)	Free Flow Orifice Area in. ²	Free Flow C _v	Effective Orifice Area in. ²	Effective Control Flow C _v	Model Number	Effective Orifice Area in. ²	Effective Control Flow C _v
F200	11 (3)	0.023	0.53	0.0102	0.230	F400-4	0.0044	0.0758
F420	11 (3)	0.023	0.53	0.0102	0.230	F600-4	0.0097	0.1530
F400	19 (5)	0.068	1.56	0.0194	0.433	F620-4	0.0044	0.0758
F620	19 (5)	0.068	1.56	0.0194	0.433	F820-4	0.0097	0.1530
F600	30 (8)	0.099	2.27	0.0344	0.787			
F820	30 (8)	0.099	2.27	0.0344	0.787			
F800	57 (15)	0.224	5.11	0.0427	0.976			
F1020	57 (15)	0.224	5.11	0.0427	0.976			
F1200	95 (25)	0.348	7.95	0.1080	2.470			
F1220	95 (25)	0.348	7.95	0.1080	2.470			
F1600	151 (40)	0.453	10.35	0.2300	5.250			
F1620	151 (40)	0.453	10.35	0.3070	7.000			
F2000	265 (70)	0.855	19.52	0.2300	5.250			
F2020	265 (70)	0.855	19.52	0.3710	8.470			
F2400	379 (100)	0.955	21.82	0.2300	5.250			
F2420	379 (100)	0.955	21.82	0.3710	8.470			
F3200	568 (150)	1.046	23.90	0.2300	5.250			
F3220	568 (150)	1.046	23.90	0.6010	13.410			

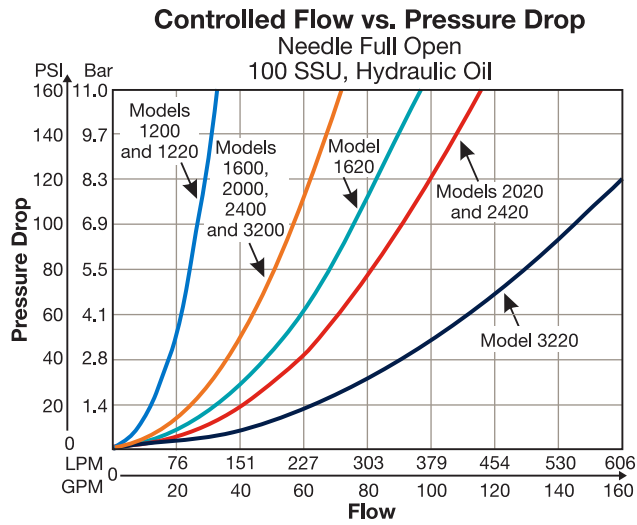
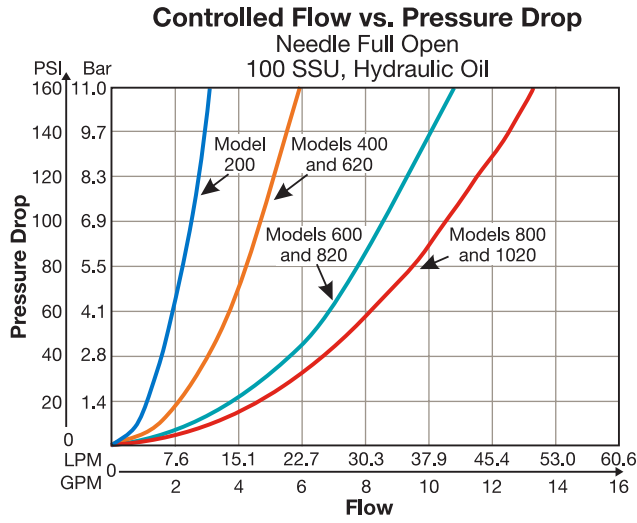

Inch equivalents for millimeter dimensions are shown in (**)

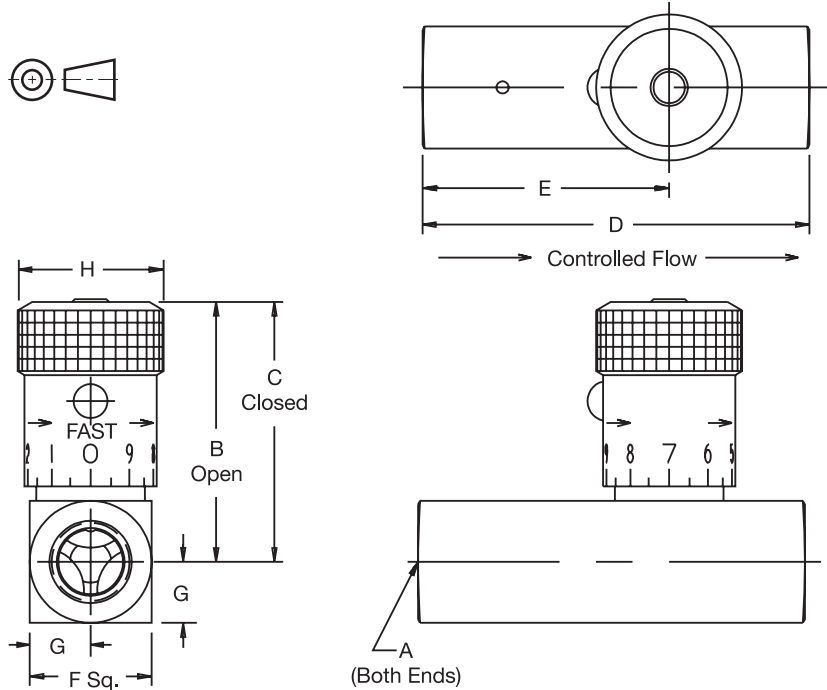

Knob Options

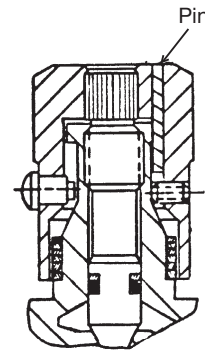

Tamperproof Option (Code "T") permanently locks knob at desired flow setting by installing a pin in predrilled hole.

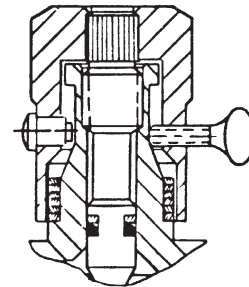

Finger screw Option (Code "F") provides this thumb-screw in place of set screw.

Model Number	Weight kg (lbs)	A	B	C	D	E	F	G	H
F200	0.1 (0.3)	1/8-27 NPTF	39.1 (1.54)	35.3 (1.39)	50.8 (2.00)	32.5 (1.28)	16.0 (0.63)	7.9 (0.31)	19.1 (0.75)
F400	0.2 (0.5)	1/4-18 NPTF	45.5 (1.79)	40.4 (1.59)	66.8 (2.63)	42.2 (1.66)	20.6 (0.81)	10.4 (0.41)	20.6 (0.81)
F420	0.2 (0.5)	7/16-20 UNF #4 SAE	41.4 (1.63)	37.6 (1.48)	68.3 (2.69)	42.9 (1.69)	20.6 (0.81)	10.4 (0.41)	19.1 (0.75)
F600	0.3 (0.7)	3/8-18 NPTF	55.4 (2.18)	49.5 (1.95)	69.9 (2.75)	44.5 (1.75)	25.4 (1.00)	12.7 (0.50)	25.4 (1.00)
F620	0.3 (0.7)	9/16-18 UNF #6 SAE	47.7 (1.88)	42.7 (1.68)	79.2 (3.12)	48.8 (1.92)	25.4 (1.00)	12.7 (0.50)	20.6 (0.81)
F800	0.7 (1.5)	1/2-14 NPTF	68.6 (2.70)	61.5 (2.42)	87.4 (3.44)	56.6 (2.23)	31.8 (1.25)	16.0 (0.63)	30.2 (1.19)
F820	0.5 (1.1)	3/4-16 UNF #8 SAE	56.9 (2.24)	51.1 (2.01)	88.9 (3.50)	53.8 (2.12)	28.4 (1.12)	14.2 (0.56)	25.4 (1.00)
F1020	0.8 (1.8)	7/8-14 UNF #10 SAE	68.6 (2.70)	61.5 (2.42)	101.6 (4.00)	65.0 (2.56)	31.8 (1.25)	15.7 (0.62)	30.2 (1.19)
F1200	1.2 (2.6)	3/4-14 NPTF	85.9 (3.38)	71.4 (2.81)	98.6 (3.88)	65.5 (2.58)	38.1 (1.50)	19.1 (0.75)	35.1 (1.38)
F1220	1.2 (2.6)	1 1/6-12 UN #12 SAE	85.9 (3.38)	71.4 (2.81)	117.3 (4.62)	76.5 (3.01)	38.1 (1.50)	19.1 (0.75)	35.1 (1.38)
F1600	2.3 (5.1)	1-11 1/2 NPTF	123.7 (4.87)	106.9 (4.21)	127.0 (5.00)	81.8 (3.22)	44.5 (1.75)	22.4 (0.88)	47.8 (1.88)*
F1620	2.3 (5.1)	1 5/16-12 UN #16 SAE	130.8 (5.15)	114.0 (4.49)	142.7 (5.62)	88.9 (3.50)	57.2 (2.25)	28.4 (1.12)	47.8 (1.88)*
F2000	3.7 (8.2)	1 1/4-11 1/2 NPTF	130.0 (5.12)	113.3 (4.46)	143.0 (5.63)	98.6 (3.88)	57.2 (2.25)	28.7 (1.13)	47.8 (1.88)*
F2020	3.7 (8.2)	1 5/8-12 UN #20 SAE	140.2 (5.52)	123.4 (4.86)	165.1 (6.50)	108.0 (4.25)	69.9 (2.75)	35.1 (1.38)	47.8 (1.88)*
F2400	4.6 (10.2)	1 1/2-11 1/2 NPTF	136.4 (5.37)	119.6 (4.71)	143.0 (5.63)	113.5 (4.47)	69.9 (2.75)	35.1 (1.38)	47.8 (1.88)*
F2420	4.6 (10.2)	1 7/8-12 UN-2B #24 SAE	143.5 (5.65)	126.7 (4.99)	184.2 (7.25)	127.0 (5.00)	76.2 (3.00)	38.1 (1.50)	47.8 (1.88)*
F3200	7.9 (17.4)	2-11 1/2 NPTF	146.1 (5.75)	129.3 (5.09)	165.1 (6.50)	134.9 (5.31)	88.9 (3.50)	44.5 (1.75)	47.8 (1.88)*
F3220	7.9 (17.4)	2 1/2-12 UN #32 SAE	163.6 (6.44)	139.4 (5.49)	228.6 (9.00)	155.7 (6.13)	101.6 (4.00)	50.8 (2.00)	47.8 (1.88)*

* = Hex

General Description

Series PCK pressure compensated flow control valves are designed to regulate flow at a selected rate, within 5%, regardless of fluctuations in inlet and outlet pressure.

Operation

Series PCK valves are factory-set for a specified flow. The flow can be changed with a different "PCK" Orifice Plug Kit (sold separately).

Features

- Available with reverse flow check.
- Flow precision within $\pm 5\%$ of full flow.

Specifications

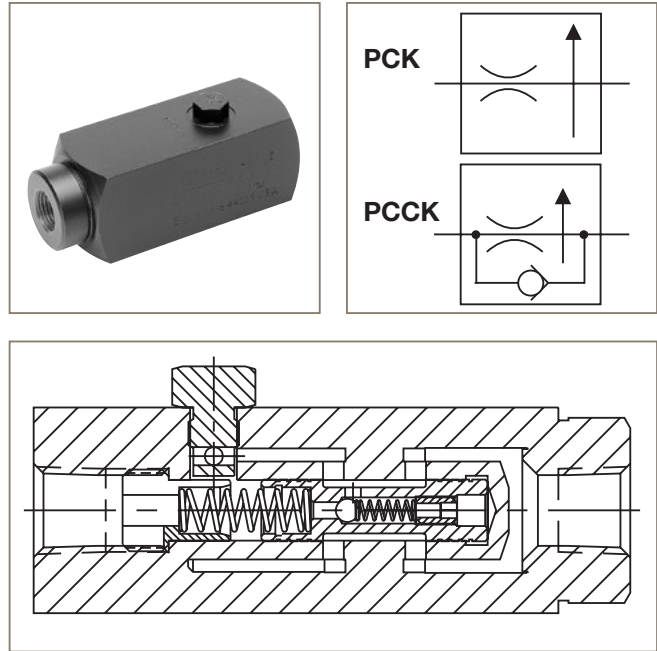

	PC*K400S PC*K620S	PC*K600S PC*K820S	PC*K800S PC*K1020S	PC*K1200S PCK1220S
Body Material	Steel			
Maximum Operating Pressure	210 Bar (3000 PSI)			
Minimum Pressure to Compensate	7 Bar (100 PSI)	7 Bar (100 PSI)	7 Bar (100 PSI)	10 Bar (150 PSI)
Temperature Range of Seal Compound	-40°C to +121°C (-40°F to +250°F) Nitrile (standard) -26°C to +205°C (-15°F to +400°F) Fluorocarbon			
Mounting	In-line			
Maximum Flow	11 LPM (3 GPM)	23 LPM (6 GPM)	57 LPM (15 GPM)	95 LPM (25 GPM)
Minimum Flow	1 LPM (0.3 GPM)	2 LPM (0.6 GPM)	6 LPM (1.5 GPM)	10 LPM (2.5 GPM)
Reverse Flow, Maximum thru Check	19 LPM (5 GPM)	30 LPM (8 GPM)	76 LPM (20 GPM)	132 LPM (35 GPM)
Pressure Drop, ΔP at Maximum Reverse Flow thru Check	3 Bar (40 PSI)	3 Bar (40 PSI)	PC*K800S: 8 Bar (115 PSI) PC*K1020S: 3 Bar (40 PSI)	PC*K1200S: 8 Bar (115 PSI) PC*K1220S: 3 Bar (40 PSI)
Port Size (in.)	PC*K400S: 1/4 NPTF PC*K620S: 9/16-18 UNF (SAE 6)	PC*K600S: 3/8 NPTF PC*K820S: 3/4-16 UNF (SAE 8)	PC*K800S: 1/2 NPTF PC*K1020S: 7/8-14 UNF (SAE 10)	PC*K1200S: 3/4 NPTF PC*K1220S: 1-1/16-12 UN (SAE 12)

* For optional reverse-flow check, insert "C" in model number at asterisk (*).

WARNING: This product can expose you to chemicals including Lead, Nickel (Metallic), or 1,3-Butadiene which are known to the State of California to cause cancer, and Lead or 1,3-Butadiene which is known to the State of California to cause birth defects and other reproductive harm. For more information go to www.P65Warnings.ca.gov.

Cat3300.indd, ddp, 09/22

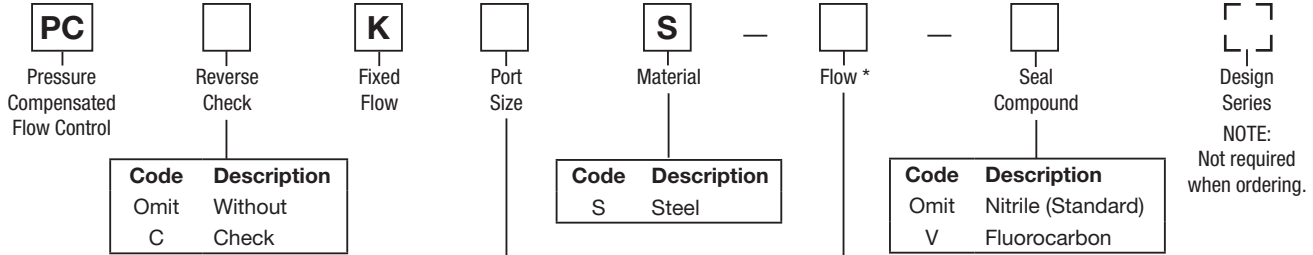

Code	Size
400	1/4"
600	3/8"
620	#6 SAE
800	1/2"
820	#8 SAE
1020	#10 SAE
1200	3/4"
1220	#12 SAE

Available Flow Settings GPM (LPM)							
PCK 400/620		PCK 600/820		PCK 800/1020		PCK 1200/1220	
GPM	(LPM)	GPM	(LPM)	GPM	(LPM)	GPM	(LPM)
0.25	(0.9)	0.50	(1.9)	2.00	(7.57)	4.00	(15.14)
0.50	(1.9)	1.00	(3.8)	3.00	(11.36)	6.00	(22.71)
0.75	(2.8)	1.50	(5.7)	4.00	(15.14)	8.00	(30.28)
1.00	(3.8)	2.00	(7.6)	5.00	(18.93)	10.00	(37.85)
1.25	(4.7)	2.50	(9.5)	6.00	(22.71)	12.00	(45.42)
1.50	(5.7)	3.00	(11.4)	7.00	(26.50)	14.00	(52.99)
1.75	(6.6)	3.50	(13.2)	8.00	(30.28)	16.00	(60.56)
2.00	(7.6)	4.00	(15.1)	9.00	(34.07)	18.00	(68.13)
2.25	(8.5)	4.50	(17.0)	10.00	(37.85)	20.00	(75.70)
2.50	(9.5)	5.00	(18.9)	11.00	(41.64)	22.00	(83.27)
2.75	(10.4)	5.50	(20.8)	12.00	(45.42)	24.00	(90.84)
3.00	(11.4)	6.00	(22.7)	13.00	(49.21)		
				14.00	(52.99)		
				15.00	(56.78)		

Note: Settings are based on using 100 SSU at +49°C (+120°F).

* To order this valve you must indicate appropriate GPM value from table. Example: 9PCK600S-3.50-V

“PK” Orifice Plug Kits

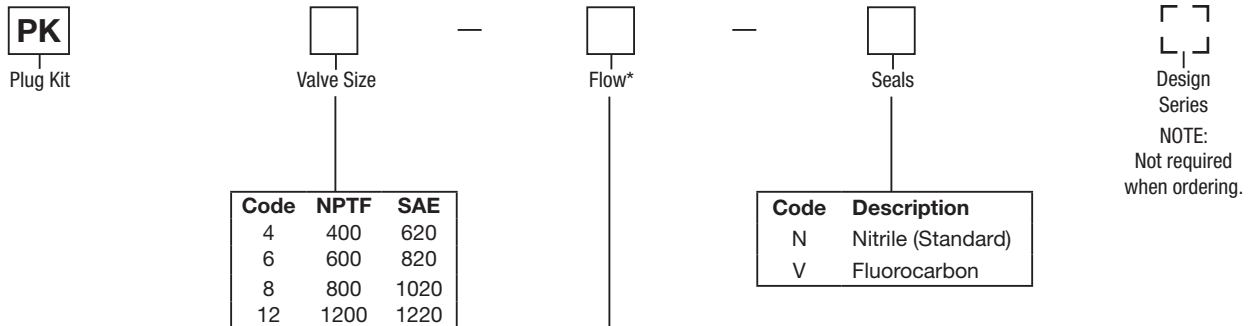

Model Number	Weight kg (lbs.)
PK4-*N	0.5 (0.1)
PK6-*N	0.5 (0.1)
PK8-*N	0.5 (0.1)
PK12-*N	0.5 (0.1)

Available Flow Settings GPM (LPM)							
PCK 400/620		PCK 600/820		PCK 800/1020		PCK 1200/1220	
GPM	(LPM)	GPM	(LPM)	GPM	(LPM)	GPM	(LPM)
0.25	(0.9)	0.50	(1.9)	2.00	(7.57)	4.00	(15.14)
0.50	(1.9)	1.00	(3.8)	3.00	(11.36)	6.00	(22.71)
0.75	(2.8)	1.50	(5.7)	4.00	(15.14)	8.00	(30.28)
1.00	(3.8)	2.00	(7.6)	5.00	(18.93)	10.00	(37.85)
1.25	(4.7)	2.50	(9.5)	6.00	(22.71)	12.00	(45.42)
1.50	(5.7)	3.00	(11.4)	7.00	(26.50)	14.00	(52.99)
1.75	(6.6)	3.50	(13.2)	8.00	(30.28)	16.00	(60.56)
2.00	(7.6)	4.00	(15.1)	9.00	(34.07)	18.00	(68.13)
2.25	(8.5)	4.50	(17.0)	10.00	(37.85)	20.00	(75.70)
2.50	(9.5)	5.00	(18.9)	11.00	(41.64)	22.00	(83.27)
2.75	(10.4)	5.50	(20.8)	12.00	(45.42)	24.00	(90.84)
3.00	(11.4)	6.00	(22.7)	13.00	(49.21)		
				14.00	(52.99)		
				15.00	(56.78)		

Note: Settings are based on using 100 SSU at +49°C (+120°F).

* To order this plug kit you must indicate appropriate GPM value from table. Example: PK6-3.50-N

Performance Curves

PC*K Series
Controlled Flow vs. Pressure Drop
 at Maximum Flow Setting
 Typical for All Sizes

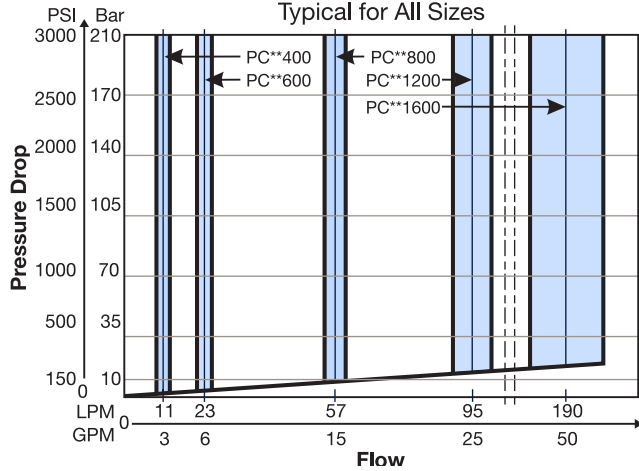

Dimensions

Inch equivalents for millimeter dimensions are shown in (**)

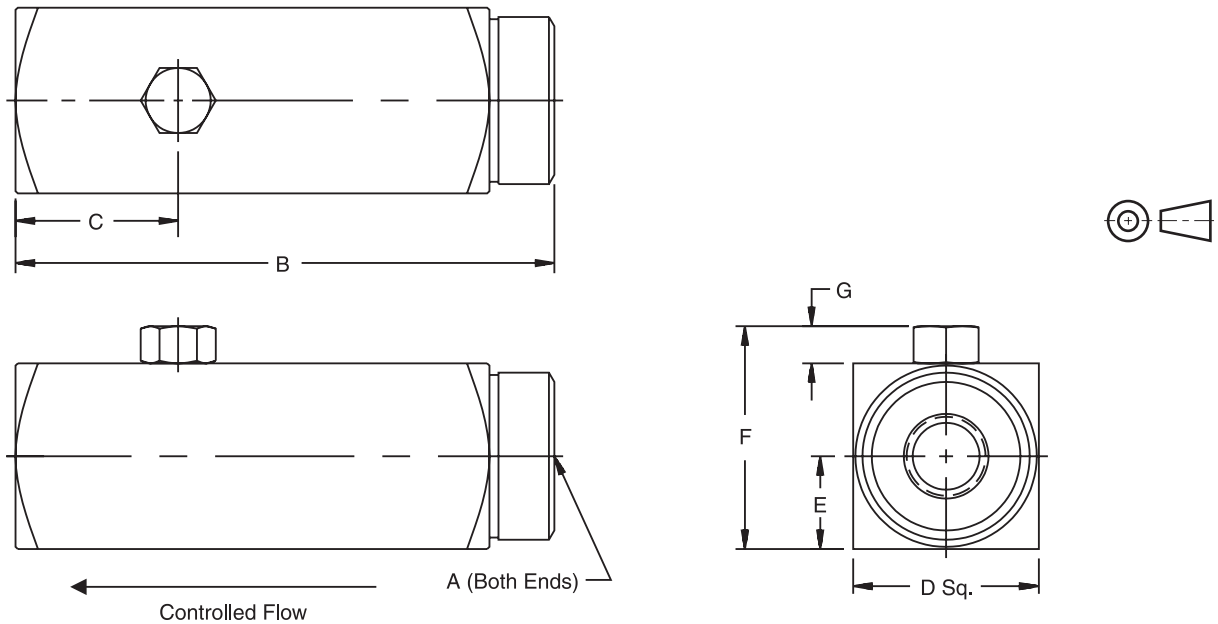

Model Number	Weight		A	B	C	D	E	F	G
	kg	(lbs)							
PC*K400/620	0.03	(0.7)	1/4-18 NPTF/9/16-18 UNF	92.2 (3.63)	27.7 (1.09)	31.8 (1.25)	17.5 (0.69)	38.1 (1.50)	6.4 (0.25)
PC*K600	1.00	(2.1)	3/8-18 NPTF	105.7 (4.16)	30.2 (1.19)	38.1 (1.50)	19.1 (0.75)	44.5 (1.75)	6.4 (0.25)
PC*K 820	1.00	(2.1)	3/4-16 UNF	112.5 (4.43)	37.3 (1.47)	38.1 (1.50)	19.1 (0.75)	44.5 (1.75)	6.4 (0.25)
PC*K800/1020	1.50	(3.3)	1/2-14 NPTF/7/8-14 UNF	125.5 (4.94)	36.6 (1.44)	44.5 (1.75)	22.4 (0.88)	50.8 (2.00)	6.4 (0.25)
PC*K1200/1220	1.50	(3.3)	3/4-14 NPTF/1 1/16-12 UNF	149.4 (5.88)	27.7 (1.09)	57.2 (2.25)	28.7 (1.13)	63.5 (2.50)	6.4 (0.25)

General Description

Series PCM pressure compensated flow control valves are designed to regulate flow at a selected rate, within 5%, regardless of fluctuations in inlet and outlet pressure.

Operation

Series PCM valves can be adjusted for required flows after being installed.

Features

- Available with reverse flow check.
- The exclusive “Colorflow” color-band reference scale on the valve stem is a great convenience and time-saver in setting the valve originally and in returning it to any previous setting.
- A simple set screw locks the valve on any desired setting.
- A tamperproof option (T) feature is also available to prevent accidental or intentional adjustment of flow setting.

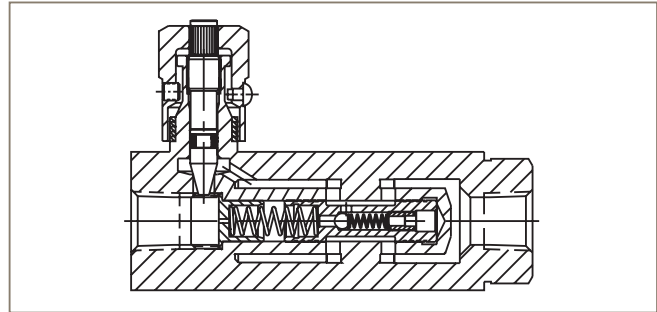
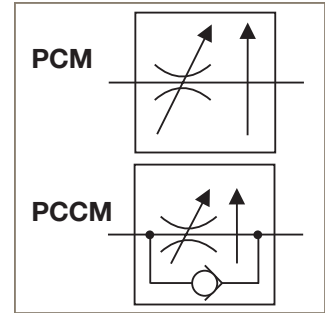

Specifications

	PC*M400S PC*M620S	PC*M600S PC*M820S	PC*M800S PC*M1020S	PC*M1200S PC*M1220S	PC*M1600S PC*M1620S	PC*M2000S
Body Material	Steel or 303 Stainless Steel					
Max. Oper. Pressure	210 Bar (3000 PSI)					
Min. Pressure to Compensate	7 Bar (100 PSI)	7 Bar (100 PSI)	7 Bar (100 PSI)	10 Bar (150 PSI)	10 Bar (150 PSI)	10 Bar (150 PSI)
Temperature Range of Seal Compound	Nitrile (standard): -40°C to +121°C (-40°F to +250°F) Fluorocarbon: -26°C to +205°C (-15°F to +400°F)					
Mounting	Inline					
Max. Flow	11 LPM (3 GPM)	23 LPM (6 GPM)	57 LPM (15 GPM)	95 LPM (25 GPM)	189 LPM (50 GPM)	303 LPM (80 GPM)
Min. Flow	1 LPM (0.3 GPM)	2 LPM (0.6 GPM)	6 LPM (1.5 GPM)	10 LPM (2.5 GPM)	19 LPM (5.0 GPM)	30 LPM (8 GPM)
Reverse Flow, Max. thru Check	19 LPM (5 GPM)	30 LPM (8 GPM)	76 LPM (20 GPM)	132 LPM (35 GPM)	227 LPM (60 GPM)	378 LPM (100 GPM)
Pressure Drop, ΔP at Max. Reverse Flow thru Check	3 Bar (40 PSI)	3 Bar (40 PSI)	PC*M800S: 8 Bar (115 PSI) PC*M1020S: 3 Bar (40 PSI)	PC*M1200S: 8 Bar (115PSI) PC*M1220S: 3 Bar (40 PSI)	10 Bar (140 PSI)	11 Bar (155 PSI)
Port Size (in.)	PC*M400S: 1/4 NPTF PC*M620S: 9/16-18 UNF (SAE 6)	PC*M600S: 3/8 NPTF PC*M820S: 3/4-16 UNF (SAE 8)	PC*M800S: 1/2 NPTF PC*M1020S: 7/8-14 UNF (SAE 10)	PC*M1200S: 3/4 NPTF PC*M1220S: 1-1/16-12 UNF (SAE 12)	PC*M1600S: 1 NPTF PC*M1620: 1-5/16-12 UNF (SAE 16)	PC*M2000S: 1 1/4" NPTF

* For optional reverse-flow check, insert “C” in model number at asterisk (*).

WARNING: This product can expose you to chemicals including Lead, Nickel (Metallic), or 1,3-Butadiene which are known to the State of California to cause cancer, and Lead or 1,3-Butadiene which is known to the State of California to cause birth defects and other reproductive harm. For more information go to www.P65Warnings.ca.gov.

Cat3300.indd, ddp, 09/22

Ordering Information

<div style="border: 1px solid black; width: 30px; height: 30px; margin: 0 auto;"></div> <p>Options</p>	<div style="border: 1px solid black; width: 30px; height: 30px; margin: 0 auto; text-align: center; font-weight: bold;">PC</div> <p>Pressure Compensated Flow Control</p>	<div style="border: 1px solid black; width: 30px; height: 30px; margin: 0 auto;"></div> <p>Reverse Check</p>	<div style="border: 1px solid black; width: 30px; height: 30px; margin: 0 auto; text-align: center; font-weight: bold;">M</div> <p>Adjustable Flow</p>	<div style="border: 1px solid black; width: 30px; height: 30px; margin: 0 auto;"></div> <p>Size</p>	<div style="border: 1px solid black; width: 30px; height: 30px; margin: 0 auto;"></div> <p>Material</p>	<div style="border: 1px solid black; width: 30px; height: 30px; margin: 0 auto;"></div> <p>Knob Options</p>	<div style="border: 1px solid black; width: 30px; height: 30px; margin: 0 auto;"></div> <p>Seals</p>	<div style="border: 1px dashed black; width: 30px; height: 30px; margin: 0 auto;"></div> <p>Design Series</p> <p>NOTE: Not required when ordering.</p>
--	---	--	--	---	---	---	--	--

<table border="1" style="width: 100%; border-collapse: collapse;"> <thead> <tr> <th>Code</th> <th>Description</th> </tr> </thead> <tbody> <tr> <td>Omit</td> <td>NPTF/SAE</td> </tr> <tr> <td>9*</td> <td>BSP</td> </tr> </tbody> </table> <p>* Code 9 can be used with sizes 400, 600, 800, 1200, 1600.</p>	Code	Description	Omit	NPTF/SAE	9*	BSP	<table border="1" style="width: 100%; border-collapse: collapse;"> <thead> <tr> <th>Code</th> <th>Description</th> </tr> </thead> <tbody> <tr> <td>Omit</td> <td>Without</td> </tr> <tr> <td>C</td> <td>Check</td> </tr> </tbody> </table>	Code	Description	Omit	Without	C	Check	<table border="1" style="width: 100%; border-collapse: collapse;"> <thead> <tr> <th>Code</th> <th>Size</th> </tr> </thead> <tbody> <tr> <td>400</td> <td>1/4"</td> </tr> <tr> <td>600*</td> <td>3/8"</td> </tr> <tr> <td>620</td> <td>#6 SAE</td> </tr> <tr> <td>800*</td> <td>1/2"</td> </tr> <tr> <td>820</td> <td>#8 SAE</td> </tr> <tr> <td>1020</td> <td>#10 SAE</td> </tr> <tr> <td>1200</td> <td>3/4"</td> </tr> <tr> <td>1220</td> <td>#12 SAE</td> </tr> <tr> <td>1600</td> <td>1"</td> </tr> <tr> <td>1620</td> <td>#16 SAE1</td> </tr> <tr> <td>2000</td> <td>1 1/4"</td> </tr> </tbody> </table> <p>* Available in Stainless Steel.</p>	Code	Size	400	1/4"	600*	3/8"	620	#6 SAE	800*	1/2"	820	#8 SAE	1020	#10 SAE	1200	3/4"	1220	#12 SAE	1600	1"	1620	#16 SAE1	2000	1 1/4"	<table border="1" style="width: 100%; border-collapse: collapse;"> <thead> <tr> <th>Code</th> <th>Description</th> </tr> </thead> <tbody> <tr> <td>Omit</td> <td>Standard Knob</td> </tr> <tr> <td>T*</td> <td>Tamperproof</td> </tr> <tr> <td>F</td> <td>Finger Screw</td> </tr> </tbody> </table> <p>* Not available above size 1200.</p>	Code	Description	Omit	Standard Knob	T*	Tamperproof	F	Finger Screw
Code	Description																																														
Omit	NPTF/SAE																																														
9*	BSP																																														
Code	Description																																														
Omit	Without																																														
C	Check																																														
Code	Size																																														
400	1/4"																																														
600*	3/8"																																														
620	#6 SAE																																														
800*	1/2"																																														
820	#8 SAE																																														
1020	#10 SAE																																														
1200	3/4"																																														
1220	#12 SAE																																														
1600	1"																																														
1620	#16 SAE1																																														
2000	1 1/4"																																														
Code	Description																																														
Omit	Standard Knob																																														
T*	Tamperproof																																														
F	Finger Screw																																														

Code	Description
Omit	Nitrile (Standard)
S	Steel
SS	Stainless Steel

Code	Description
Omit	Nitrile (Standard)
V	Fluorocarbon (Standard on Stainless Steel)

Performance Curves

PC*M Series
Controlled Flow vs. Pressure Drop
 Typical for All Sizes
 150 SSU, Hydraulic Oil

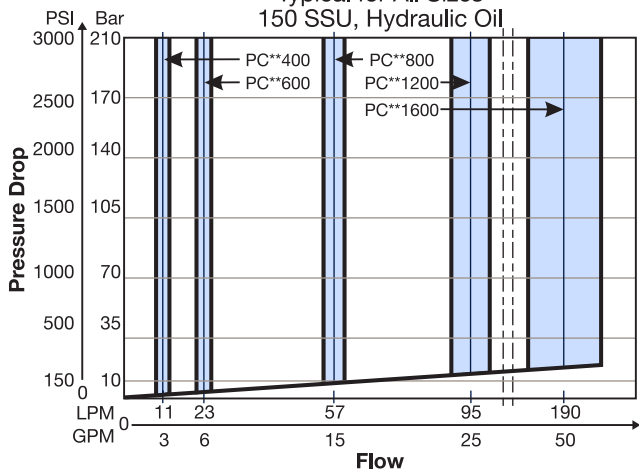

Reverse Flow vs. Pressure Drop
 At Maximum and Minimum Flow Settings
 150 SSU, Hydraulic Oil

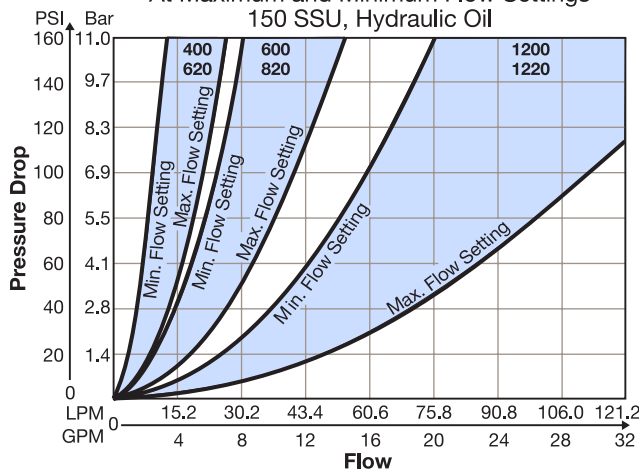

PCCM 800 and 1600 Series
Reverse Flow vs. Pressure Drop
 At Maximum and Minimum Flow Settings
 150 SSU, Hydraulic Oil

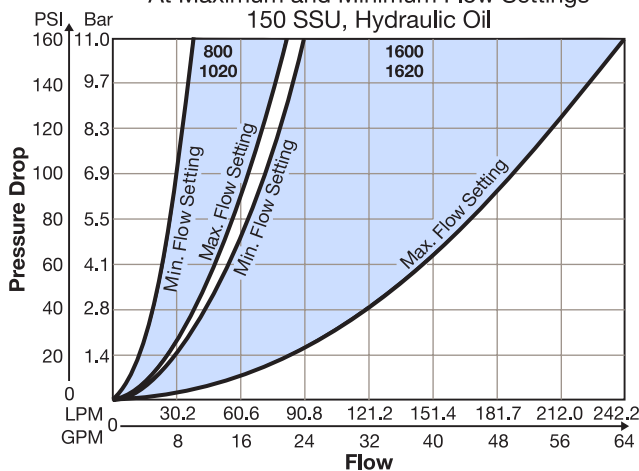

PCCM 2000S Series
Reverse Flow vs. Pressure Drop
 At Maximum and Minimum Flow Settings
 150 SSU, Hydraulic Oil

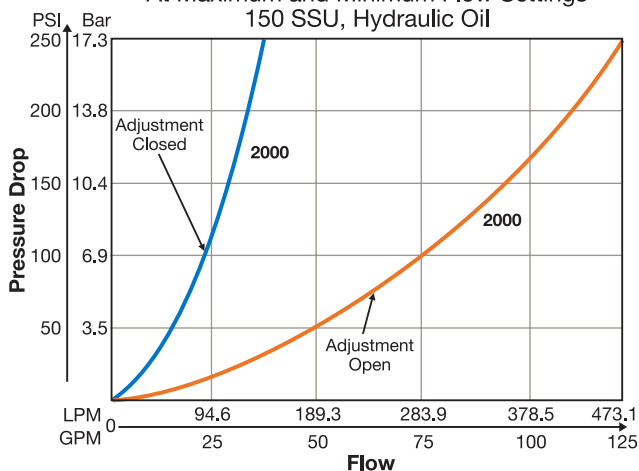

Inch equivalents for millimeter dimensions are shown in (**)

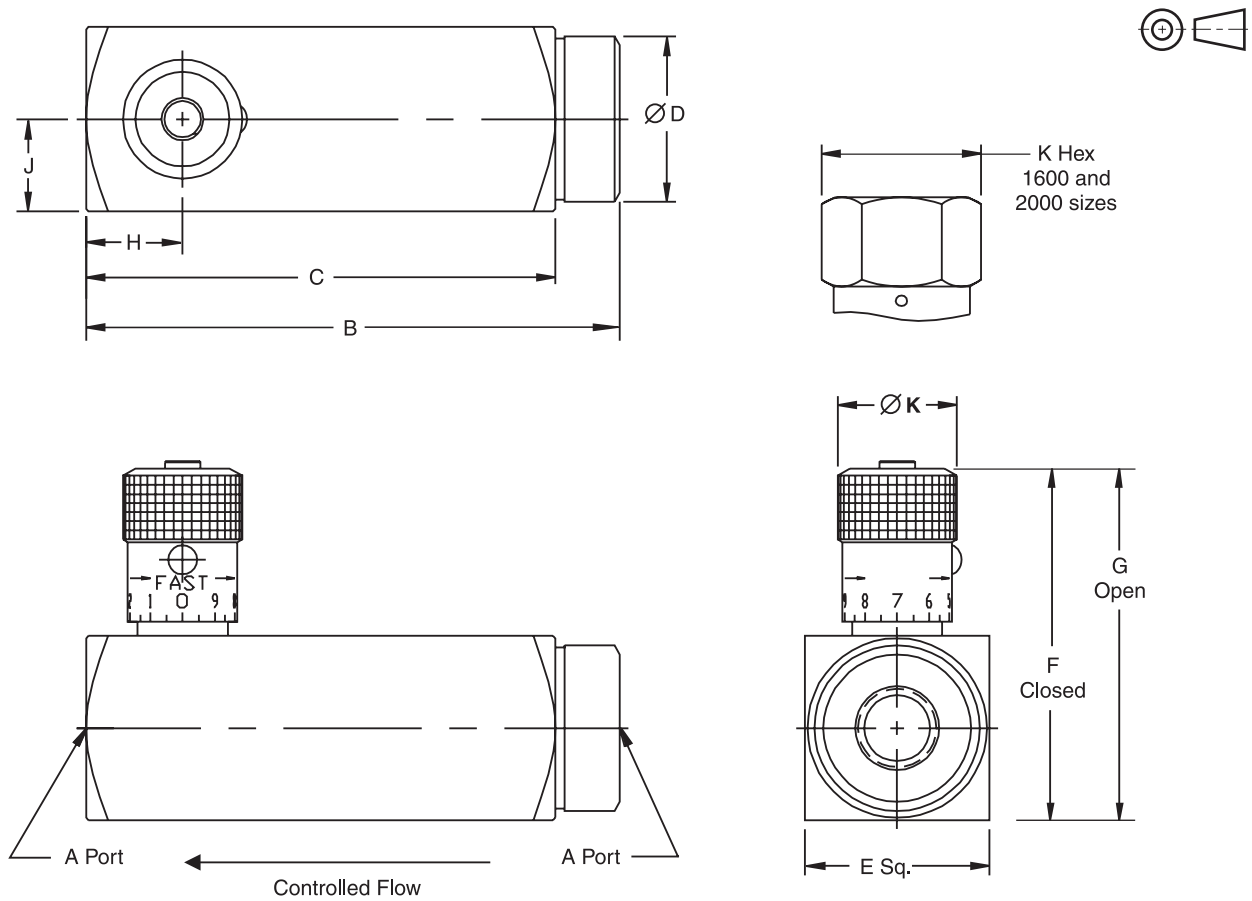

Model Number	Weight kg (lbs)	A	B	C	D	E	F	G	H	J	I
PC*M400/620	0.8	1/4-18 NPTF	92.2	81.0	28.7	31.8	64.0	69.3	16.8	17.5	20.6
	(1.8)	9/16-18 UNF	(3.63)	(3.19)	(1.13)	(1.25)	(2.52)	(2.73)	(0.66)	(0.69)	(0.81)
PC*M600/820	1.0*	3/8-18 NPTF	105.7	93.0	31.8	38.1	73.7	80.0	17.5	19.1	25.4
	(2.2)*	3/4-16 UNF	(4.16)	(3.66)	(1.25)	(1.50)	(2.90)	(3.15)	(0.69)	(0.75)	(1.00)
PC*M800/1020	1.7	1/2-14 NPTF	125.5	109.5	38.1	44.5	95.0	102.6	22.4	22.4	30.2
	(3.7)	7/8-14 UNF	(4.94)	(4.31)	(1.50)	(1.75)	(3.74)	(4.04)	(0.88)	(0.88)	(1.19)
PC*M1200/1220	3.6	3/4-14 NPTF	149.4	130.3	50.8	57.2	115.8	128.5	27.7	28.7	35.1
	(8.0)	1 1/16-12 UNF	(5.88)	(5.13)	(2.00)	(2.25)	(4.56)	(5.06)	(1.09)	(1.13)	(1.38)
PC*M1600/1620	6.6	1-11 1/2 NPTF	176.3	155.7	63.5	69.9	158.2	175.3	33.3	35.1	47.8
	(14.6)	1 5/16-12 UNF	(6.94)	(6.13)	(2.50)	(2.75)	(6.23)	(6.90)	(1.31)	(1.38)	(1.88)
PC*M2000	11.8 (26.0)	1 1/4-11 1/2 NPTF	212.9 (8.38)	190.5 (7.50)	76.2 (3.00)	88.9 (3.50)	182.1 (7.17)	201.2 (7.92)	41.4 (1.63)	44.5 (1.75)	47.8 (1.88)

* Weights are for PC*M600; weights for PC*M820 are 1.4 kg (3.1lbs.)

General Description

Series N needle valves are ideal as speed controls on hydraulic and pneumatic systems where a reverse flow check is not needed. They provide excellent control and a reliable shut-off in a very small envelope.

Operation

A two-step needle allows fine adjustment at low flow by using the first three turns of the adjusting knob. The next three turns open the valve to full flow, and also provide standard throttling adjustments.

Features

- The exclusive “Colorflow” color-band reference scale on the valve stem is a great convenience and time-saver in setting the valve originally and in returning it to any previous setting.
- A simple set screw locks the valve on any desired setting.
- A tamperproof option (T) feature is also available to prevent accidental or intentional adjustment of flow setting.
- Bi-directional flow.

Specifications

Maximum Operating Pressure	<p>Brass: 140 Bar (2000 PSI); except for N1600 brass which is 35 Bar (500 PSI)</p> <p>Steel & Stainless Steel: 350 Bar (5000 PSI) for 200 thru 1220; 210 Bar (3000 PSI) for all other sizes</p>
Material	<p>Body: Steel, Brass, or 303 Stainless Steel</p> <p>Knob: Steel - Zinc plated</p> <p>Spring: 302 Stainless Steel</p> <p>Needle: 416 Stainless Steel</p>
Temperature Range of Seal Compound	<p>-40°C to +121°C (-40°F to +250°F) Nitrile (standard)</p> <p>-26°C to +205°C (-15°F to +400°F) Fluorocarbon</p>

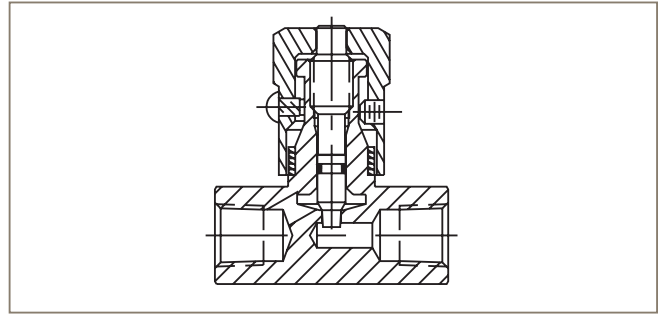
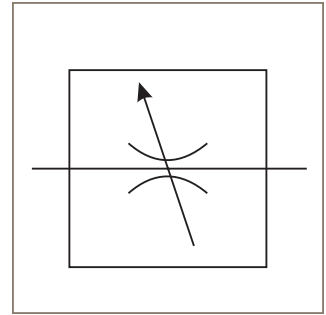

WARNING: This product can expose you to chemicals including Lead, Nickel (Metallic), or 1,3-Butadiene which are known to the State of California to cause cancer, and Lead or 1,3-Butadiene which is known to the State of California to cause birth defects and other reproductive harm. For more information go to www.P65Warnings.ca.gov.

Cat3300.indd, ddp, 09/22

<div style="border: 1px solid black; width: 30px; height: 30px; margin: 0 auto;"></div> <p>Options</p>	<div style="border: 1px solid black; width: 30px; height: 30px; margin: 0 auto; text-align: center; font-weight: bold; font-size: 1.2em;">N</div> <p>Series N</p>	<div style="border: 1px solid black; width: 30px; height: 30px; margin: 0 auto;"></div> <p>Size</p>	<div style="border: 1px solid black; width: 30px; height: 30px; margin: 0 auto;"></div> <p>Material</p>	<div style="border: 1px solid black; width: 30px; height: 30px; margin: 0 auto;"></div> <p>Needle Options</p>	<div style="border: 1px solid black; width: 30px; height: 30px; margin: 0 auto;"></div> <p>Knob Options</p>	<div style="border: 1px solid black; width: 30px; height: 30px; margin: 0 auto;"></div> <p>Seal Compound</p>	<div style="border: 1px dashed black; width: 30px; height: 30px; margin: 0 auto;"></div> <p>Design Series</p> <p>NOTE: Not required when ordering.</p>																																																																	
<table border="1" style="width: 100%; border-collapse: collapse;"> <thead> <tr> <th>Code</th> <th>Description</th> </tr> </thead> <tbody> <tr> <td>Omit</td> <td>NPTF/SAE</td> </tr> <tr> <td>8*</td> <td>BSPT</td> </tr> <tr> <td>9**</td> <td>BSPP</td> </tr> </tbody> </table> <p>* Code 8 can be used with sizes 400, 600, 800 Steel only</p> <p>** Code 9 can be used with sizes 200, 400, 600, 800, 1200, 1600, 2000</p>	Code	Description	Omit	NPTF/SAE	8*	BSPT	9**	BSPP	<table border="1" style="width: 100%; border-collapse: collapse;"> <thead> <tr> <th>Code</th> <th>Size</th> </tr> </thead> <tbody> <tr> <td>200*</td> <td>1/8"</td> </tr> <tr> <td>400*†</td> <td>1/4"</td> </tr> <tr> <td>420</td> <td>#4 SAE</td> </tr> <tr> <td>600*†</td> <td>3/8"</td> </tr> <tr> <td>620</td> <td>#6 SAE</td> </tr> <tr> <td>800*†</td> <td>1/2"</td> </tr> <tr> <td>820*</td> <td>#8 SAE</td> </tr> <tr> <td>1020</td> <td>#10 SAE</td> </tr> <tr> <td>1200*</td> <td>3/4"</td> </tr> <tr> <td>1220</td> <td>#12 SAE</td> </tr> <tr> <td>1600*</td> <td>1"</td> </tr> <tr> <td>1620</td> <td>#16 SAE</td> </tr> <tr> <td>2000</td> <td>1 1/4"</td> </tr> <tr> <td>2020</td> <td>#20 SAE</td> </tr> </tbody> </table> <p>* Sizes available in Brass.</p> <p>† Sizes available in Stainless Steel.</p>	Code	Size	200*	1/8"	400*†	1/4"	420	#4 SAE	600*†	3/8"	620	#6 SAE	800*†	1/2"	820*	#8 SAE	1020	#10 SAE	1200*	3/4"	1220	#12 SAE	1600*	1"	1620	#16 SAE	2000	1 1/4"	2020	#20 SAE	<table border="1" style="width: 100%; border-collapse: collapse;"> <thead> <tr> <th>Code</th> <th>Description</th> </tr> </thead> <tbody> <tr> <td>B</td> <td>Brass</td> </tr> <tr> <td>S</td> <td>Steel</td> </tr> <tr> <td>SS*</td> <td>Stainless Steel</td> </tr> </tbody> </table> <p>Series N Brass Valves can be used for both air and oil service.</p> <p>* Available in 400, 600, and 800 sizes, NPT only.</p>	Code	Description	B	Brass	S	Steel	SS*	Stainless Steel	<table border="1" style="width: 100%; border-collapse: collapse;"> <thead> <tr> <th>Code</th> <th>Description</th> </tr> </thead> <tbody> <tr> <td>Omit</td> <td>Standard Knob</td> </tr> <tr> <td>T*</td> <td>Tamperproof</td> </tr> <tr> <td>F</td> <td>Finger Screw</td> </tr> </tbody> </table> <p>* Not available above size 1220.</p>	Code	Description	Omit	Standard Knob	T*	Tamperproof	F	Finger Screw	<table border="1" style="width: 100%; border-collapse: collapse;"> <thead> <tr> <th>Code</th> <th>Description</th> </tr> </thead> <tbody> <tr> <td>Omit</td> <td>Standard</td> </tr> <tr> <td>4</td> <td>Fine Metering (200, 400, 420, 600, 620, 820 sizes)</td> </tr> </tbody> </table>	Code	Description	Omit	Standard	4	Fine Metering (200, 400, 420, 600, 620, 820 sizes)	<table border="1" style="width: 100%; border-collapse: collapse;"> <thead> <tr> <th>Code</th> <th>Description</th> </tr> </thead> <tbody> <tr> <td>Omit</td> <td>Nitrile (Standard)</td> </tr> <tr> <td>V</td> <td>Fluorocarbon (Standard on Stainless Steel)</td> </tr> </tbody> </table>	Code	Description	Omit	Nitrile (Standard)	V	Fluorocarbon (Standard on Stainless Steel)	
Code	Description																																																																							
Omit	NPTF/SAE																																																																							
8*	BSPT																																																																							
9**	BSPP																																																																							
Code	Size																																																																							
200*	1/8"																																																																							
400*†	1/4"																																																																							
420	#4 SAE																																																																							
600*†	3/8"																																																																							
620	#6 SAE																																																																							
800*†	1/2"																																																																							
820*	#8 SAE																																																																							
1020	#10 SAE																																																																							
1200*	3/4"																																																																							
1220	#12 SAE																																																																							
1600*	1"																																																																							
1620	#16 SAE																																																																							
2000	1 1/4"																																																																							
2020	#20 SAE																																																																							
Code	Description																																																																							
B	Brass																																																																							
S	Steel																																																																							
SS*	Stainless Steel																																																																							
Code	Description																																																																							
Omit	Standard Knob																																																																							
T*	Tamperproof																																																																							
F	Finger Screw																																																																							
Code	Description																																																																							
Omit	Standard																																																																							
4	Fine Metering (200, 400, 420, 600, 620, 820 sizes)																																																																							
Code	Description																																																																							
Omit	Nitrile (Standard)																																																																							
V	Fluorocarbon (Standard on Stainless Steel)																																																																							

Model Number	Max. Flow LPM (GPM)	Effective Orifice Area Control Flow in. ²	Effective Control Flow C _v	Model Number	Max. Flow LPM (GPM)	Effective Orifice Area Control Flow in. ²	Effective Control Flow C _v	Model Number	Effective Orifice Area Control Flow in. ²	Effective Control Flow C _v
N200	11 (3)	0.0102	0.230	N1200	95 (25)	0.1080	2.470	N400-4	0.0044	0.0758
N420	11 (3)	0.0102	0.230	N1220	95 (25)	0.1080	2.470	N600-4	0.0097	0.1530
N400	19 (5)	0.0194	0.433	N1600	151 (40)	0.2300	5.250	N620-4	0.0044	0.0758
N620	19 (5)	0.0194	0.433	N1620	151 (40)	0.3070	7.000	N820-4	0.0097	0.1530
N600	30 (8)	0.0344	0.787	N2000	264 (70)	0.2300	5.250			
N820	30 (8)	0.0344	0.787	N2020	264 (70)	0.3710	8.470			
N800	57 (15)	0.0427	0.976							
N1020	57 (15)	0.0427	0.976							

Performance Curves

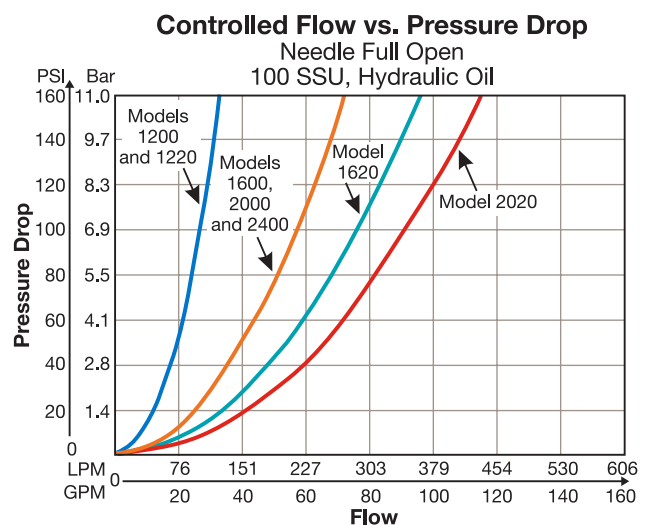
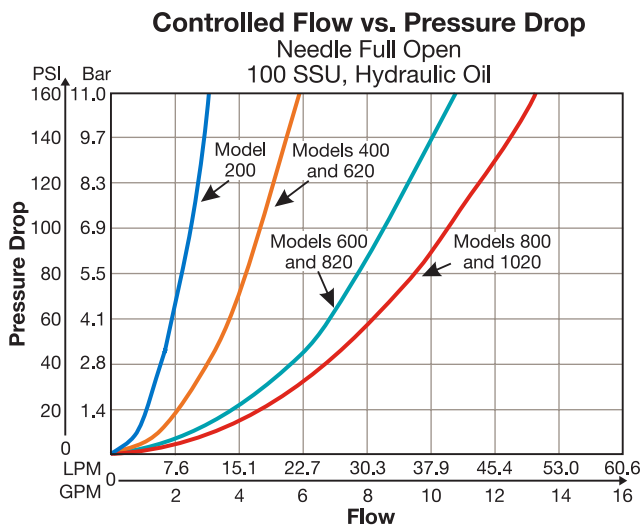

Inch equivalents for millimeter dimensions are shown in (**)

Knob Options

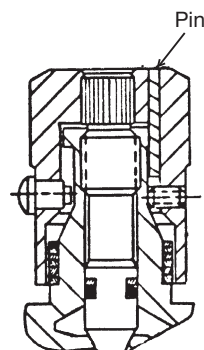
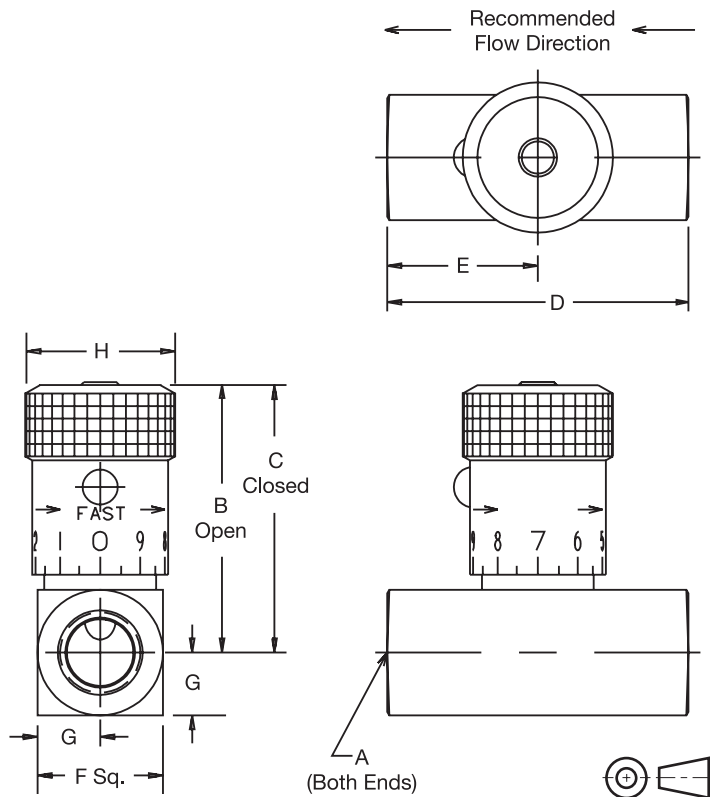

Tamperproof Option (Code "T") permanently locks knob at desired flow setting by installing a pin in predrilled hole.

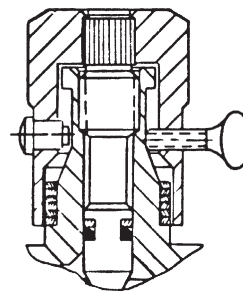

Finger screw Option (Code "F") provides this thumbscrew in place of set screw.

Model Number	Weight kg (lbs)	A	B	C	D	E	F	G	H
N200	0.1 (0.3)	1/8-27 NPTF	39.1 (1.54)	35.3 (1.39)	38.1 (1.50)	19.1 (0.75)	15.7 (0.62)	7.9 (0.31)	19.1 (0.75)
N400	0.2 (0.5)	1/4-18 NPTF	45.5 (1.79)	40.4 (1.59)	50.8 (2.00)	25.4 (1.00)	20.6 (0.81)	10.4 (0.41)	20.6 (0.81)
N420	0.1 (0.3)	7/16-20 UNF #4 SAE	41.4 (1.63)	37.6 (1.48)	50.8 (2.00)	25.4 (1.00)	20.6 (0.81)	10.4 (0.41)	19.1 (0.75)
N600	0.4 (0.9)	3/8-18 NPTF	55.4 (2.18)	49.5 (1.95)	63.5 (2.50)	31.8 (1.25)	25.4 (1.00)	12.7 (0.50)	25.4 (1.00)
N620	0.2 (0.5)	9/16-18 UNF #6 SAE	47.7 (1.88)	42.7 (1.68)	60.5 (2.38)	30.2 (1.19)	25.4 (1.00)	12.7 (0.50)	20.6 (0.81)
N800	0.6 (1.3)	1/2-14 NPTF	68.6 (2.70)	61.5 (2.42)	66.5 (2.62)	33.3 (1.31)	31.8 (1.25)	15.7 (0.62)	30.2 (1.19)
N820	0.4 (0.9)	3/4-16 UNF #8 SAE	56.9 (2.24)	51.1 (2.01)	76.2 (3.00)	38.1 (1.50)	28.4 (1.12)	14.2 (0.56)	25.4 (1.00)
N1020	0.6 (1.3)	7/8-14 UNF #10 SAE	68.6 (2.70)	61.5 (2.42)	88.9 (3.50)	44.5 (1.75)	31.8 (1.25)	15.7 (0.62)	30.2 (1.19)
N1200	1.0 (2.2)	3/4-14 NPTF	85.9 (3.38)	71.4 (2.81)	82.6 (3.25)	41.1 (1.62)	38.1 (1.50)	19.1 (0.75)	35.1 (1.38)
N1220	1.0 (2.2)	1 1/6-12 UN #12 SAE	85.9 (3.38)	71.4 (2.81)	101.6 (4.00)	50.8 (2.00)	38.1 (1.50)	19.1 (0.75)	35.1 (1.38)
N1600	2.1 (4.6)	1-11 1/2 NPTF	123.7 (4.87)	106.9 (4.21)	108.0 (4.25)	53.8 (2.12)	44.5 (1.75)	22.4 (0.88)	47.8 (1.88)*
N1620	2.1 (4.6)	1 5/16-12 UN #16 SAE	130.8 (5.15)	114.0 (4.49)	108.0 (4.25)	53.8 (2.12)	57.2 (2.25)	28.4 (1.12)	47.8 (1.88)*
N2000	2.9 (6.4)	1 1/4-11 1/2 NPTF	130.0 (5.12)	113.3 (4.46)	108.0 (4.253)	53.8 (2.12)	57.2 (2.25)	28.7 (1.13)	47.8 (1.88)*
N2020	2.9 (6.4)	1 5/8-12 UN #20 SAE	140.2 (5.52)	123.4 (4.86)	114.3 (4.50)	57.2 (2.25)	69.9 (2.75)	60.5 (2.38)	47.8 (1.88)*

* = Hex

General Description

Series MV high-precision metering and shut-off valves allow extremely close control of fluids used in actuating and governing equipment.

Operation

The standard needle allows fine adjustment at low flow by using the first three turns of the adjusting knob. The next three turns open the valve to full flow, and also provide standard throttling adjustments.

Features

- The exclusive “Colorflow” color-band reference scale on the valve stem is a great convenience and time-saver in setting the valve originally and in returning it to any previous setting.
- Fine and Micro-fine needles available for extremely fine control.
- MVK mounting kit makes panel mounting simple.
- High efficiency o-ring stem seal that eliminates packing.

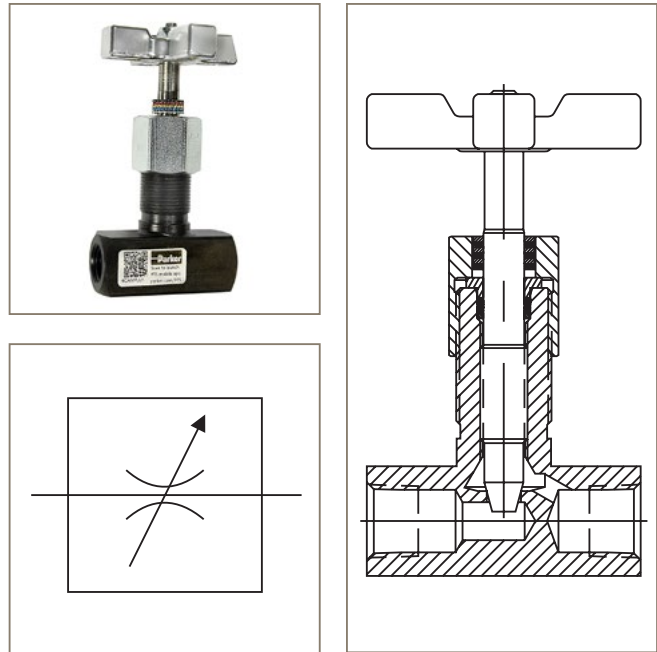

Specifications

Maximum Operating Pressure	Steel: 420 Bar (6000 PSI) for MV261, 461, 661, 861. 350 Bar (5000 PSI) for MV200, 400, 401, 420, 600, 601, 620, 822, 820, 1020, 1200, 1220. 210 Bar (3000 PSI) for all other sizes and styles.
Material	Body: Steel Handle: Zinc alloy - Zinc chromate Needle: 416 Stainless Steel
Temperature Range of Seal Compound	-40°C to +121°C (-40°F to +250°F) Nitrile (standard) -26°C to +205°C (-15°F to +400°F) Fluorocarbon

Performance Curves

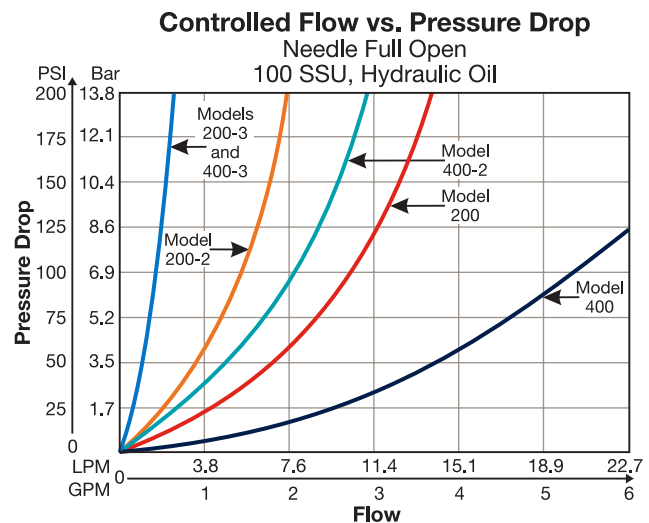
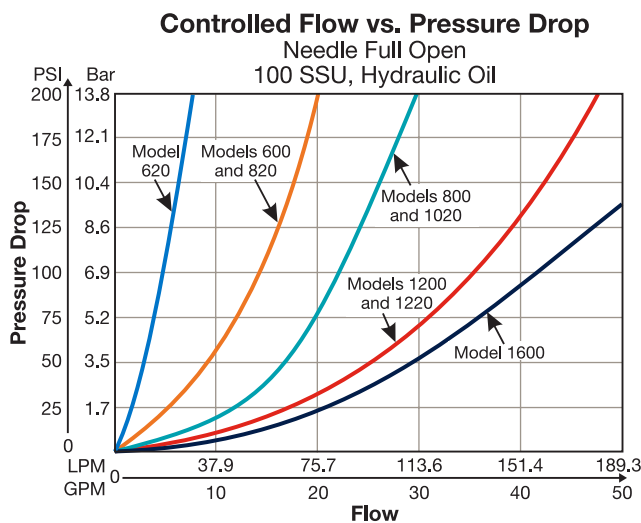

WARNING: This product can expose you to chemicals including Lead, Nickel (Metallic), or 1,3-Butadiene which are known to the State of California to cause cancer, and Lead or 1,3-Butadiene which is known to the State of California to cause birth defects and other reproductive harm. For more information go to www.P65Warnings.ca.gov.

Cat3300.indd, ddp, 09/22



Ordering Information

Options	Series MV	Size	Material	Needle Options	Seal Compound	Design Series																																																																											
□	MV	□	S	□	□	☐																																																																											
Options	Series MV	Size	Material	Needle Options	Seal Compound	Design Series																																																																											
<table border="1" style="width: 100%; border-collapse: collapse;"> <thead> <tr> <th>Code</th> <th>Description</th> </tr> </thead> <tbody> <tr> <td>Omit</td> <td>NPTF/SAE</td> </tr> <tr> <td>9*</td> <td>BSPP</td> </tr> </tbody> </table> <p>* Code 9 can be used with sizes 200, 261, 400, 461, 600, 661, 800, 861, 1200, 1261, and 1600.</p>	Code	Description	Omit	NPTF/SAE	9*	BSPP	<table border="1" style="width: 100%; border-collapse: collapse;"> <thead> <tr> <th>Code†</th> <th>Size</th> <th>Code†</th> <th>Size</th> </tr> </thead> <tbody> <tr><td>200</td><td>1/8"</td><td>661</td><td>3/8"</td></tr> <tr><td>260</td><td>1/8"</td><td>681</td><td>#6 SAE</td></tr> <tr><td>261</td><td>1/8"</td><td>800</td><td>1/2"</td></tr> <tr><td>400</td><td>1/4"</td><td>820</td><td>#8 SAE</td></tr> <tr><td>401</td><td>1/4"</td><td>860</td><td>1/2"</td></tr> <tr><td>420</td><td>#4 SAE</td><td>861</td><td>1/2"</td></tr> <tr><td>460</td><td>1/4"</td><td>1020</td><td>#10 SAE</td></tr> <tr><td>461</td><td>1/4"</td><td>1200</td><td>3/4"</td></tr> <tr><td>600</td><td>3/8"</td><td>1220</td><td>#12 SAE</td></tr> <tr><td>601</td><td>3/8"</td><td>1261</td><td>3/4"</td></tr> <tr><td>620</td><td>#6 SAE</td><td>-1600</td><td>1"</td></tr> <tr><td>660</td><td>3/8"</td><td>-1620</td><td>#16 SAE</td></tr> </tbody> </table> <p>† 00 is Female to Female 01 is Female to Male 6* is Right Angle 60 is Male to Female 61 is Female to Female</p>	Code†	Size	Code†	Size	200	1/8"	661	3/8"	260	1/8"	681	#6 SAE	261	1/8"	800	1/2"	400	1/4"	820	#8 SAE	401	1/4"	860	1/2"	420	#4 SAE	861	1/2"	460	1/4"	1020	#10 SAE	461	1/4"	1200	3/4"	600	3/8"	1220	#12 SAE	601	3/8"	1261	3/4"	620	#6 SAE	-1600	1"	660	3/8"	-1620	#16 SAE	<table border="1" style="width: 100%; border-collapse: collapse;"> <thead> <tr> <th>Code</th> <th>Description</th> </tr> </thead> <tbody> <tr> <td>S</td> <td>Steel</td> </tr> </tbody> </table>	Code	Description	S	Steel	<table border="1" style="width: 100%; border-collapse: collapse;"> <thead> <tr> <th>Code</th> <th>Description</th> </tr> </thead> <tbody> <tr> <td>Omit</td> <td>Standard 30° Taper</td> </tr> <tr> <td>2*</td> <td>Fine</td> </tr> <tr> <td>3*</td> <td>Micro-fine</td> </tr> </tbody> </table> <p>* 2 and 3 not available in sizes 660 and above.</p>	Code	Description	Omit	Standard 30° Taper	2*	Fine	3*	Micro-fine	<table border="1" style="width: 100%; border-collapse: collapse;"> <thead> <tr> <th>Code</th> <th>Description</th> </tr> </thead> <tbody> <tr> <td>Omit</td> <td>Nitrile (Standard)</td> </tr> <tr> <td>V</td> <td>Fluorocarbon</td> </tr> </tbody> </table>	Code	Description	Omit	Nitrile (Standard)	V	Fluorocarbon	<p>NOTE: Not required when ordering.</p>
Code	Description																																																																																
Omit	NPTF/SAE																																																																																
9*	BSPP																																																																																
Code†	Size	Code†	Size																																																																														
200	1/8"	661	3/8"																																																																														
260	1/8"	681	#6 SAE																																																																														
261	1/8"	800	1/2"																																																																														
400	1/4"	820	#8 SAE																																																																														
401	1/4"	860	1/2"																																																																														
420	#4 SAE	861	1/2"																																																																														
460	1/4"	1020	#10 SAE																																																																														
461	1/4"	1200	3/4"																																																																														
600	3/8"	1220	#12 SAE																																																																														
601	3/8"	1261	3/4"																																																																														
620	#6 SAE	-1600	1"																																																																														
660	3/8"	-1620	#16 SAE																																																																														
Code	Description																																																																																
S	Steel																																																																																
Code	Description																																																																																
Omit	Standard 30° Taper																																																																																
2*	Fine																																																																																
3*	Micro-fine																																																																																
Code	Description																																																																																
Omit	Nitrile (Standard)																																																																																
V	Fluorocarbon																																																																																

Mounting Kit

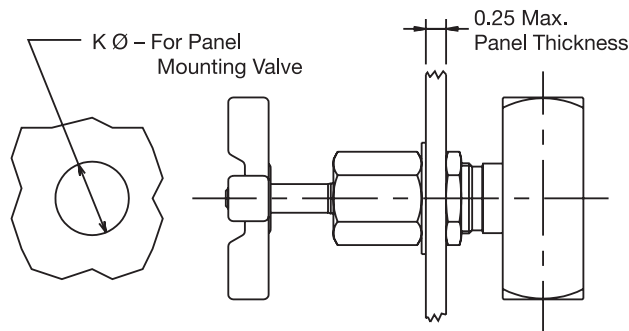

Panel Mounting Kits

Kit Number	K	Valve Model	Kit Number	K	Valve Model
MVK2	15.0 (0.59)	MV200	MVK8	29.5 (1.16)	MV800
		MV260			MV860
		MV261S			MV861S
		MV420			MV1020
MVK4	19.8 (0.78)	MV400	MVK12	35.8 (1.41)	MV1200
		MV401			MV1220
		MV460S			MV1261
		MV461S			
MVK6	23.1 (0.91)	MV620	MVK16	35.8 (1.41)	MV-1600
		MV600			MV-1620
		MV601			
		MV660			
		MV661S			
		MV681			
		MV820			

Model Number	Free Flow Rate, Max. LPM (GPM)	Effective Orifice Area Control Flow in. ²	Effective Control Flow C _v
MV200	11 (3)	0.0107	0.244
MV260	11 (3)	0.0107	0.244
MV261	11 (3)	0.0107	0.244
MV420	11 (3)	0.0107	0.244
MV200-2	7 (1.8)	0.0053	0.121
MV260-2	7 (1.8)	0.0053	0.121
MV261-2	7 (1.8)	0.0053	0.121
MV420-2	7 (1.8)	0.0053	0.121
MV200-3	2 (0.5)	0.0014	0.032
MV260-3	2 (0.5)	0.0014	0.032
MV261-3	2 (0.5)	0.0014	0.032
MV420-3	2 (0.5)	0.0014	0.032
MV400	19 (5)	0.0216	0.493
MV460	19 (5)	0.0216	0.493
MV461	19 (5)	0.0216	0.493
MV620	19 (5)	0.0216	0.493
MV400-2	11 (2.8)	0.0081	0.186
MV460-2	11 (2.8)	0.0081	0.186
MV461-2	11 (2.8)	0.0081	0.186
MV620-2	11 (2.8)	0.0081	0.186
MV400-3	2 (0.5)	0.0017	0.039
MV460-3	2 (0.5)	0.0017	0.039
MV461-3	2 (0.5)	0.0017	0.039
MV620-3	2 (0.5)	0.0017	0.039
MV600	30 (8)	0.0567	1.294
MV660	30 (8)	0.0567	1.294
MV661	30 (8)	0.0567	1.294
MV681	30 (8)	0.0567	1.294
MV820	30 (8)	0.0567	1.294
MV600-2	1.8 (0.5)	0.0180	0.466
MV600-3	0.28 (0.1)	0.0027	0.0326
MV800	57 (15)	0.0845	1.930
MV860	57 (15)	0.0845	1.930
MV861	57 (15)	0.0845	1.930
MV1020	57 (15)	0.0845	1.930
MV1200	95 (25)	0.1400	3.205
MV1220	95 (25)	0.1400	3.205
MV1261	95 (25)	0.1400	3.205
MV-1600	151 (40)	0.1675	3.829
MV-1620	151 (40)	0.1675	3.829

Inch equivalents for millimeter dimensions are shown in (**)

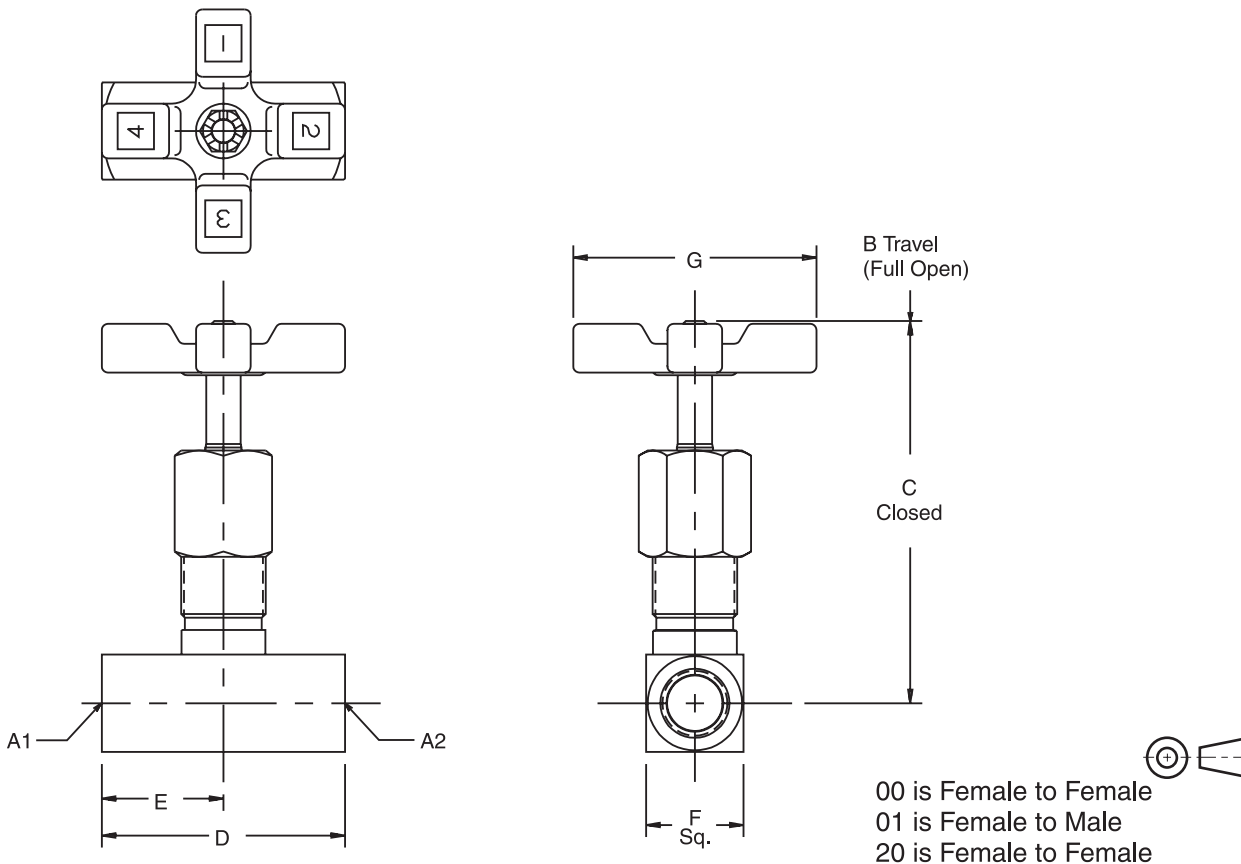

Model Number	Weight kg (lbs)	A1	A2	B	C	D	E	F	G
MV200	0.1 (0.3)	1/8-27 NPTF Female	1/8-27 NPTF Female	69.1 (2.72)	63.8 (2.51)	38.1 (1.50)	19.1 (0.75)	15.7 (0.62)	44.5 (1.75)
MV400	0.3 (0.7)	1/4-18 NPTF Female	1/4-18 NPTF Female	86.9 (3.42)	81.5 (3.21)	50.8 (2.00)	25.4 (1.00)	20.6 (0.81)	50.8 (2.00)
MV401	0.3 (0.7)	1/4-18 NPTF Male	1/4-18 NPTF Female	86.9 (3.42)	81.5 (3.21)	55.4 (2.18)	30.0 (1.18)	20.6 (0.81)	50.8 (2.00)
MV420	0.1 (0.3)	7/16-20 UNF #4 SAE	7/16-20 UNF #4 SAE	71.6 (2.82)	66.3 (2.61)	50.8 (2.00)	25.4 (1.00)	20.6 (0.81)	44.5 (1.75)
MV600	0.5 (1.1)	3/8-18 NPTF Female	3/8-18 NPTF Female	99.6 (3.92)	91.9 (3.62)	63.5 (2.50)	31.8 (1.25)	25.4 (1.00)	63.5 (2.50)
MV601	0.5 (1.1)	3/8-18 NPTF Male	3/8-18 NPTF Female	99.6 (3.92)	91.9 (3.62)	68.1 (2.68)	36.3 (1.43)	25.4 (1.00)	63.5 (2.50)
MV620	0.5 (1.1)	9/16-18 UNF #6 SAE	9/16-18 UNF #6 SAE	89.2 (3.51)	83.8 (3.30)	60.5 (2.38)	30.2 (1.19)	25.4 (1.00)	50.8 (2.00)
MV800	1.0 (2.2)	1/2-14 NPTF Female	1/2-14 NPTF Female	129.3 (5.09)	116.6 (4.59)	66.5 (2.62)	33.3 (1.31)	31.8 (1.25)	82.6 (3.25)
MV820	0.5 (1.1)	3/4-16 UNF #8 SAE	3/4-16 UNF #8 SAE	108.7 (4.28)	101.1 (3.98)	76.2 (3.00)	38.1 (1.50)	28.4 (1.12)	63.5 (2.50)
MV1020	1.0 (2.2)	7/8-14 UNF #10 SAE	7/8-14 UNF #10 SAE	129.5 (5.10)	116.6 (4.59)	88.9 (3.50)	44.5 (1.75)	31.8 (1.25)	82.6 (3.25)
MV1200	1.6 (3.5)	3/4-14 NPTF Female	3/4-14 NPTF Female	141.8 (5.58)	127.8 (5.03)	82.6 (3.25)	41.1 (1.62)	38.1 (1.50)	98.6 (3.88)
MV1220	1.6 (3.5)	1 1/16-12 UN #12 SAE	1 1/16-12 UN #12 SAE	141.8 (5.58)	127.8 (5.03)	101.6 (4.00)	50.8 (2.00)	38.1 (1.50)	98.6 (3.88)
MV1600	1.9 (4.2)	1-11 1/2 NPTF Female	1-11 1/2 NPTF Female	146.8 (5.78)	132.8 (5.23)	108.0 (4.25)	53.8 (2.12)	44.5 (1.75)	98.6 (3.88)
MV1620	1.9 (4.2)	1 5/16-12 UN #16 SAE	1 5/16-12 UN #16 SAE	152.9 (6.02)	138.9 (5.47)	108.0 (4.25)	53.8 (2.12)	57.2 (2.25)	98.6 (3.88)

An optional MVK mounting kit makes panel mounting quite simple.

Cat3300.indd, ddp, 09/22



Inch equivalents for millimeter dimensions are shown in (**)

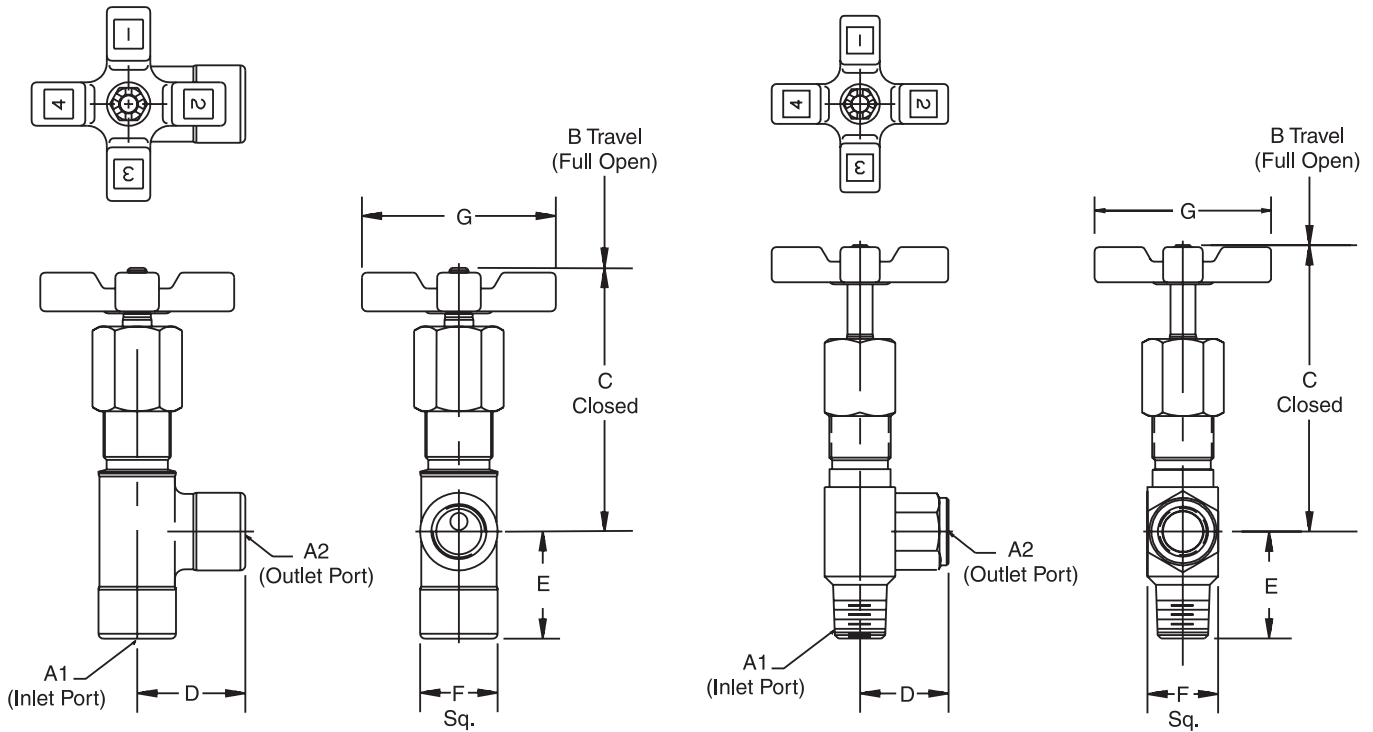

61 is Female to Female

60 is Male to Female

Model Number	Weight kg (lbs)	A1	A2	B	C	D	E	F	G
MV260	0.1 (0.3)	1/8-27 NPTF Male	1/8-27 NPTF Female	72.4 (2.85)	67.1 (2.64)	19.1 (0.75)	22.1 (0.87)	15.7 (0.62)	44.5 (1.75)
MV261	0.1 (0.3)	1/8-27 NPTF Female	1/8-27 NPTF Female	93.98 (3.70)	60.7 (2.39)	26.9 (1.06)	26.9 (1.06)	17.5 (0.69)	44.5 (1.75)
MV460	0.3 (0.7)	1/4-18 NPTF Male	1/4-18 NPTF Female	90.2 (3.55)	84.8 (3.34)	27.2 (1.07)	30.7 (1.21)	20.6 (0.81)	50.8 (2.00)
MV461	0.3 (0.7)	1/4-18 NPTF Female	1/4-18 NPTF Female	86.1 (3.39)	76.4 (3.01)	33.5 (1.32)	31.2 (1.23)	22.3 (0.88)	50.8 (2.00)
MV660	0.5 (1.1)	3/8-18 NPTF Male	3/8-18 NPTF Female	110.7 (4.36)	103.1 (4.06)	31.8 (1.25)	34.8 (1.37)	25.4 (1.00)	63.5 (2.50)
MV661	0.5 (1.1)	3/8-18 NPTF Female	3/8-18 NPTF Female	98.04 (3.86)	86.4 (3.40)	38.3 (1.51)	35.0 (1.38)	25.4 (1.00)	63.5 (2.50)
MV860	1.0 (2.2)	1/2-14 NPTF Male	1/2-14 NPTF Female	133.4 (5.25)	120.7 (4.75)	36.8 (1.45)	42.7 (1.68)	31.8 (1.25)	82.6
MV861	0.5 (1.1)	1/2-14 NPTF Female	1/2-14 NPTF Female	118.3 (4.66)	106.9 (4.21)	43.43 (1.71)	40.3 (1.59)	29.4 (1.16)	82.6 (3.25)
MV1261	1.6 (3.5)	3/4-14 NPTF Female	3/4-14 NPTF Female	146.8 (5.78)	132.8 (5.23)	44.5 (1.75)	41.1 (1.62)	38.1 (1.50)	98.6 (3.88)

An optional MVK mounting kit makes panel mounting quite simple.

General Description

Series MVI cartridge-type needle valves are designed for installation in a precision-machined cavity made in the manifold of the machine. Dimensional machining for the required cavity is provided on page 23.

Properly installed in precision-machined cavities, these needle valves provide precise metering control and full shutoff of flow. An o-ring and backup ring installed on the cartridge fully isolate the inlet and outlet ports of the machined cavity from each other.

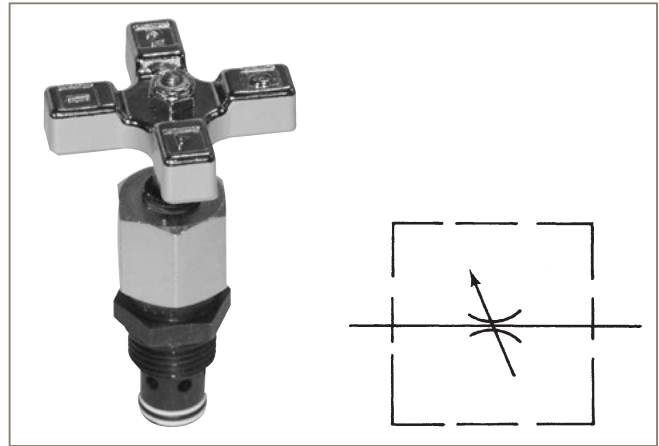

Features

- The exclusive “Colorflow” color-band reference scale on the valve stem is a great convenience and time-saver in setting the valve originally and in returning it to any previous setting.
- Fine and Micro-fine needles available for extremely fine control.
- High efficiency o-ring stem seal that eliminates packing.

Specifications

Maximum Operating Pressure	350 Bar (5000 PSI)	
Flow	See table.	
Material	Steel, compatible in steel or aluminum manifold block cavities	
Temperature Range of Seal Compound	-40°C to +121°C (-40°F to +250°F)	Nitrile (standard)
	-26°C to +205°C (-15°F to +400°F)	Fluorocarbon

Flow Data

Model Number	Maximum Flow		ΔP @ Maximum Flow		Orifice Area in. ² Full Open	C_v^* Factor	Valve Size (in)
	LPM (GPM)	Bar (PSI)	Bar (PSI)	(100)			
MVI400	19 (5)	7 (100)	7 (100)	(100)	0.0216	0.493	1/4
MVI400-2	11 (2.8)	15 (200)	15 (200)	(200)	0.0081	0.186	1/4
MVI400-3	2 (0.5)	15 (200)	15 (200)	(200)	0.0014	0.032	1/4
MVI600	30 (8)	2 (35)	2 (35)	(35)	0.0567	1.294	3/8
MVI800	57 (15)	3 (45)	3 (45)	(45)	0.0845	1.930	1/2
MVI1200	95 (25)	4 (50)	4 (50)	(50)	0.1400	3.205	3/4

* C_v factor – Flow of water in GPM that valve will pass @ ΔP of 0.1 Bar (1 PSI).

WARNING: This product can expose you to chemicals including Lead, Nickel (Metallic), or 1,3-Butadiene which are known to the State of California to cause cancer, and Lead or 1,3-Butadiene which is known to the State of California to cause birth defects and other reproductive harm. For more information go to www.P65Warnings.ca.gov.

Cat3300.indd, ddp, 09/22

Performance Curves

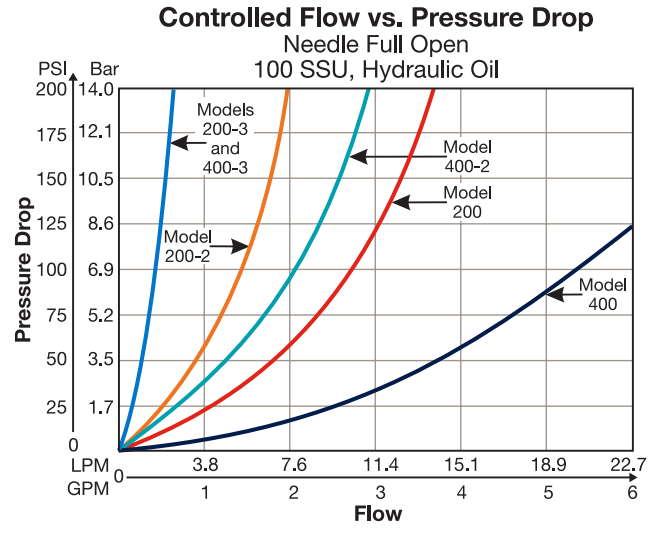
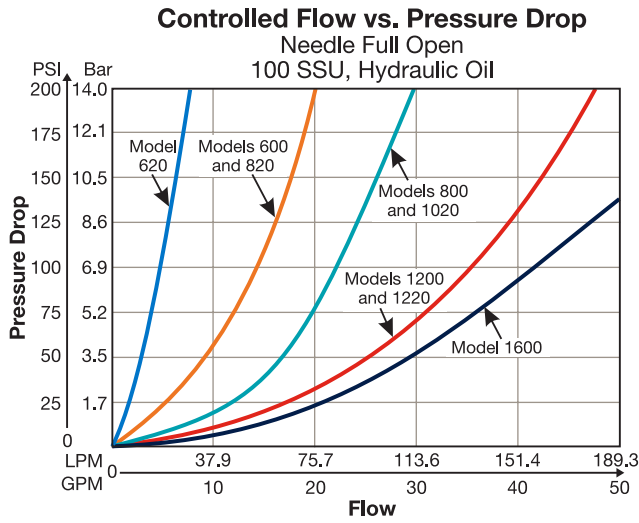

Ordering Information

MVI
 Cartridge
 Needle Valve

Size

Code	Size
400	1/4"
600	3/8"
800	1/2"
1220	#12 SAE

S
 Material

Code	Description
S	Steel

Needle Options

Code	Description
Omit	Standard
2*	Fine
3*	Micro-fine

* Available on MVI400 only.

Seals

Code	Description
Omit	Nitrile (Standard)
V	Fluorocarbon

Inch equivalents for millimeter dimensions are shown in (**)

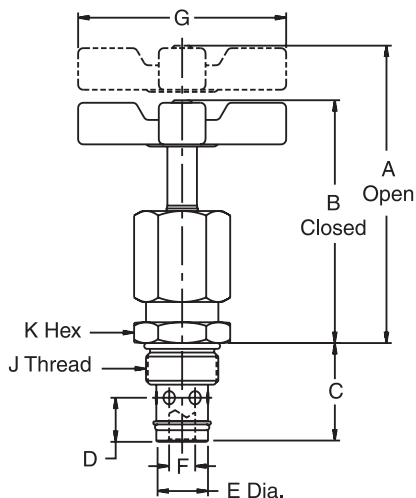

Model Number	Weight kg (lbs)	A	B	C	D	E	F	G	J	K
MVI400S *	0.2 (0.4)	64.5 (2.54)	59.4 (2.34)	25.4 (1.00)	10.9 (0.43)	14.2 (0.56)	4.6 (0.18)	50.8 (2.00)	3/4-16UNF-2A	22.1 (0.87)
MVI600S	0.3 (0.6)	80.3 (3.16)	72.6 (2.86)	30.0 (1.18)	13.5 (0.53)	15.7 (0.62)	7.9 (0.31)	63.5 (2.50)	7/8-14UNF-2A	25.4 (1.00)
MVI800S	0.5 (1.2)	91.2 (3.59)	78.5 (3.09)	39.6 (1.56)	15.2 (0.60)	20.3 (0.80)	9.4 (0.37)	82.6 (3.25)	1 1/16-12UN-2A	31.8 (1.25)
MVI1200S	0.9 (2.0)	101.6 (4.00)	87.6 (3.45)	43.4 (1.71)	19.1 (0.75)	26.9 (1.06)	11.7 (0.46)	98.3 (3.87)	1 5/16-12UN-2A	38.1 (1.50)

Machining Detail Installation Cavity

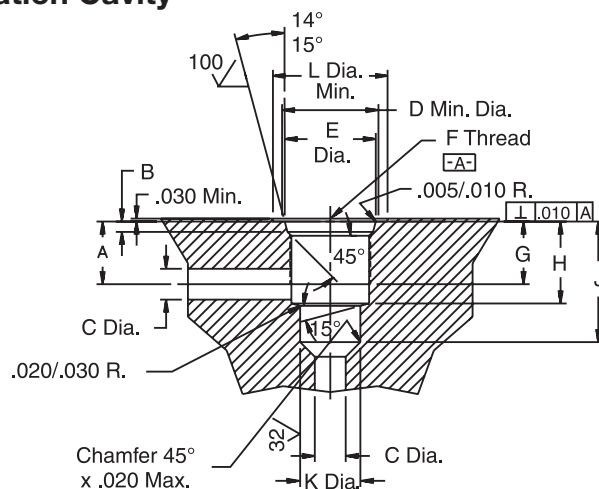

Model Number	A	B	C	D	E	F	G	H	J	K	L
MVI400S *	14.2 (0.56)	2.5/2.9 (0.100/0.115)	5.3 (0.21)	22.1 (0.87)	20.6/20.7 (0.811/0.816)	3/4-16 UNF-2B	14.2 (0.56)	17.8 (0.70)	26.9 (1.06)	14.3/14.3 (0.562/0.564)	30.2 (1.19)
MVI600S	16.5 (0.65)	2.5/2.9 (0.100/0.115)	8.1 (0.32)	25.4 (1.00)	23.9/24.1 (0.942/0.947)	7/8-14 UNF-2B	16.5 (0.65)	21.6 (0.85)	31.8 (1.25)	15.8/15.9 (0.624/0.626)	34.1 (1.34)
MVI800S	24.1 (0.95)	3.3/3.7 (0.130/0.145)	10.2 (0.40)	31.8 (1.25)	29.2/29.3 (1.148/1.153)	1 1/16-12 UN-2B	19.1 (0.75)	30.0 (1.18)	41.1 (1.62)	20.6/20.7 (0.811/0.813)	41.4 (1.63)
MVI1200S	24.6 (0.97)	3.3/3.7 (0.130/0.145)	12.7 (0.50)	38.1 (1.50)	35.5/35.6 (1.398/1.403)	1 5/16-12 UN-2B	19.1 (0.75)	31.8 (1.25)	45.2 (1.78)	26.9/27.0 (1.062/1.064)	48.5 (1.91)

General Description

Series C check valves permit free flow in one direction, and dependable shut-off in the reverse direction.

Operation

When pressure going through the valve is increased to the cracking level, the valve opens. When the pressure is reduced to below the cracking level, the valve closes.

Features

- Stainless steel poppets standard.
- Soft seal poppets are standard in some variations.
- Triangular retainers guide the poppets, and hold the spring firmly in place even under high velocity and shock.

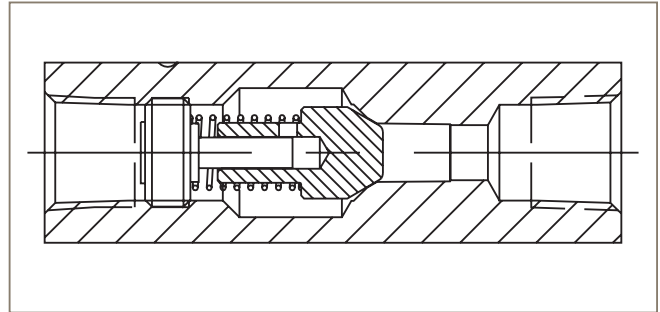
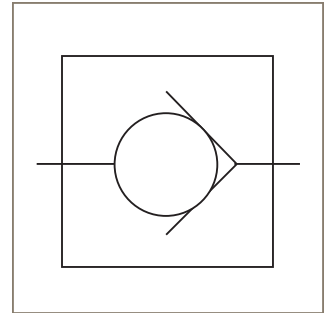

Specifications

Maximum Operating Pressure	Brass: 140 Bar (2000 PSI); except for C1600 brass which is 35 Bar (500 PSI) Steel & Stainless Steel: 350 Bar (5000 PSI) for 200 thru 1220; 210 Bar (3000 PSI) for all other sizes
Material	Body: Steel, Brass, or 303 Stainless Steel Spring: 302 Stainless Steel Poppet: 416 Stainless Steel Retainer: 416 Stainless Steel
Poppets	Soft seal poppet is standard for 200 through 800/1020 size.
Nominal Cracking Pressure	Standard: 0.4 Bar (5 PSI) Optional: 1.38 Bar (20 PSI) 4.48 Bar (65 PSI)
Temperature Range of Seal Compound	-40°C to +121°C (-40°F to +250°F) Nitrile (standard) -26°C to +205°C (-15°F to +400°F) Fluorocarbon

Performance Curves

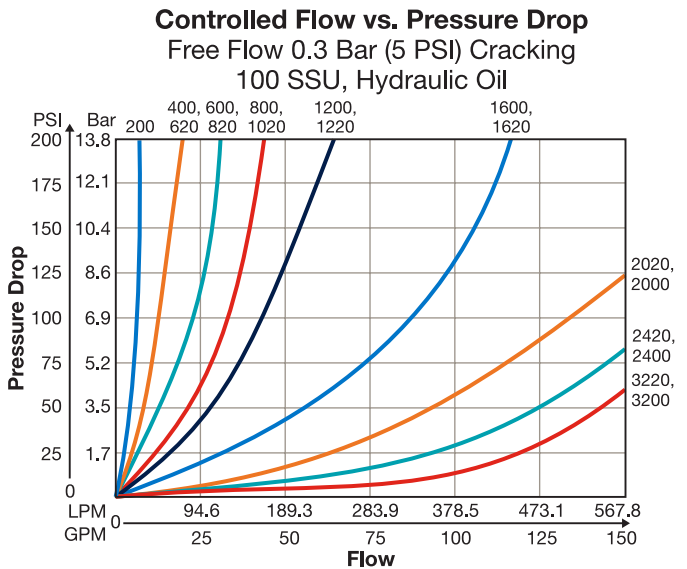

WARNING: This product can expose you to chemicals including Lead, Nickel (Metallic), or 1,3-Butadiene which are known to the State of California to cause cancer, and Lead or 1,3-Butadiene which is known to the State of California to cause birth defects and other reproductive harm. For more information go to www.P65Warnings.ca.gov.

Cat3300.indd, ddp, 09/22



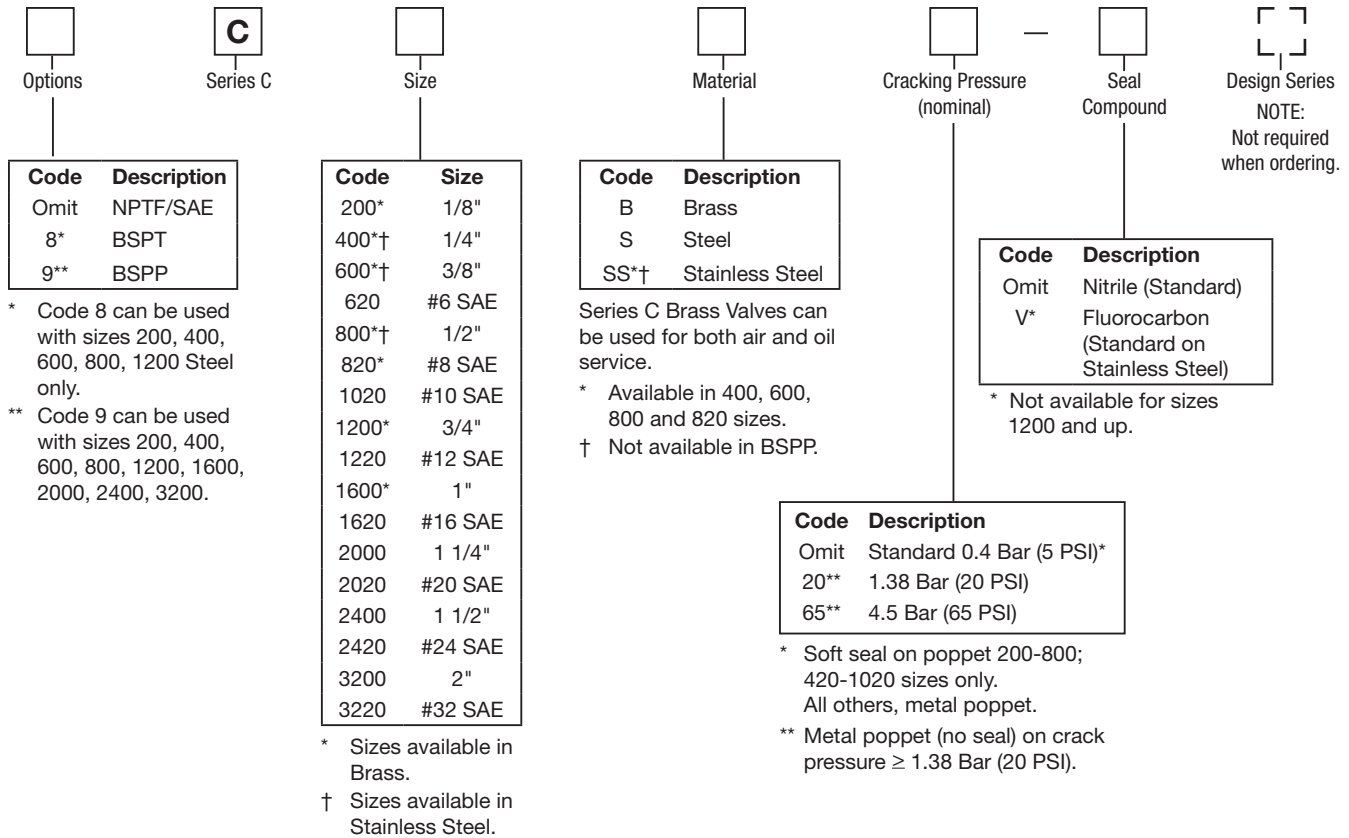

Model Number	Maximum Flow LPM (GPM)		Effective Orifice Area Control Flow in. ²	Effective Control Flow C _v
C200	11	(3)	0.023	0.53
C400	19	(5)	0.068	1.56
C620	19	(5)	0.068	1.56
C600	30	(8)	0.099	2.27
C820	30	(8)	0.099	2.27
C800	57	(15)	0.224	5.11
C1020	57	(15)	0.224	5.11
C1200	95	(25)	0.348	7.95
C1220	95	(25)	0.348	7.95
C1600	151	(40)	0.453	10.35
C1620	151	(40)	0.453	10.35
C2000	265	(70)	0.855	19.52
C2020	265	(70)	0.855	19.52
C2400	379	(100)	0.955	21.82
C2420	379	(100)	0.955	21.82
C3200	568	(150)	1.046	23.90
C3220	568	(150)	1.046	23.90

Inch equivalents for millimeter dimensions are shown in (**)

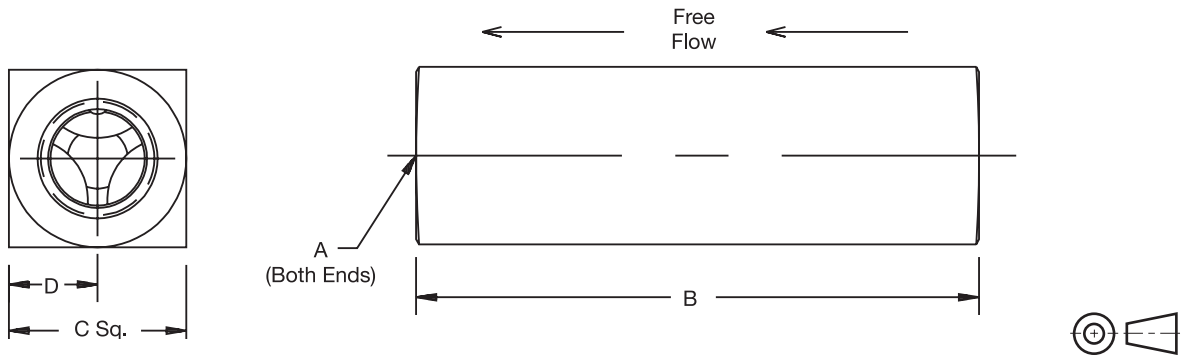

Model Number	Weight		A	B	C	D
	kg	(lbs)				
C200	0.05	(0.1)	1/8-27 NPTF	50.8 (2.00)	16.0 (0.63)	7.9 (0.31)
C400	0.2	(0.4)	1/4-18 NPTF	66.8 (2.63)	20.6 (0.81)	10.4 (0.41)
C600	0.2	(0.5)	3/8-18 NPTF	69.9 (2.75)	25.4 (1.00)	12.7 (0.50)
C620	0.2	(0.5)	9/16-18 UNF #6 SAE	79.2 (3.12)	25.4 (1.00)	12.7 (0.50)
C800	0.6	(1.3)	1/2-14 NPTF	87.4 (3.44)	31.8 (1.25)	16.0 (0.63)
C820	0.3	(0.7)	3/4-16 UNF #8 SAE	88.9 (3.50)	28.4 (1.12)	14.2 (0.56)
C1020	0.6	(1.3)	7/8-14 UNF #10 SAE	101.6 (4.00)	31.8 (1.25)	15.7 (0.62)
C1200	0.9	(2.0)	3/4-14 NPTF	98.6 (3.88)	38.1 (1.50)	19.1 (0.75)
C1220	0.9	(2.0)	1 1/6-12 UN #12 SAE	117.3 (4.62)	38.1 (1.50)	19.1 (0.75)
C1600	1.5	(3.3)	1-11 1/2 NPTF	127.0 (5.00)	44.5 (1.75)	22.4 (0.88)
C1620	1.5	(3.3)	1 5/16-12 UN #16 SAE	142.7 (5.62)	57.2 (2.25)	28.4 (1.12)
C2000	2.8	(6.2)	1 1/4-11 1/2 NPTF	143.0 (5.63)	57.2 (2.25)	28.7 (1.13)
C2020	2.8	(6.2)	1 5/8-12 UN #20 SAE	165.1 (6.50)	69.9 (2.75)	35.1 (1.38)
C2400	3.8	(8.4)	1 1/2-11 1/2 NPTF	143.0 (5.63)	69.9 (2.75)	35.1 (1.38)
C2420	3.8	(8.4)	1 7/8-12 UN #24 SAE	184.2 (7.25)	76.2 (3.00)	38.1 (1.50)
C3200	7.0	(15.4)	2-11 1/2 NPTF	165.1 (6.50)	88.9 (3.50)	44.5 (1.75)
C3220	7.0	(15.4)	2 1/2-12 UN #32 SAE	228.6 (9.00)	101.6 (4.00)	50.8 (2.00)

General Description

Series GF valves isolate gages from damage and inaccurate readings caused by line pressure surges and hydraulic hammer.

Operation

The GF uses a capillary orifice to smooth out line pulsations and surges without the use of any moving parts.

Features

- One piece construction.
- The GF requires no adjustment or maintenance.

Specifications

Maximum Operating Pressure	210 Bar (3000 PSI)
-----------------------------------	--------------------

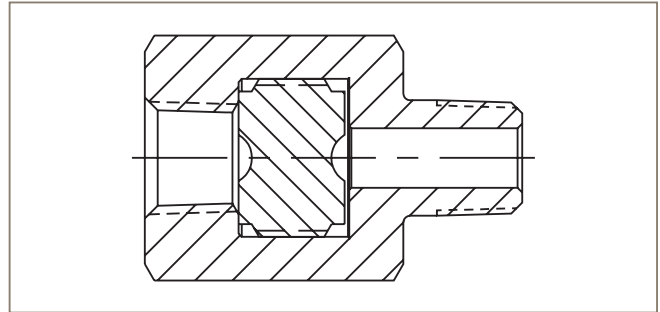
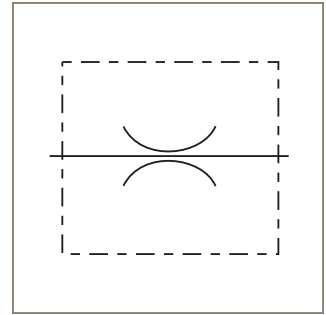

Ordering Information

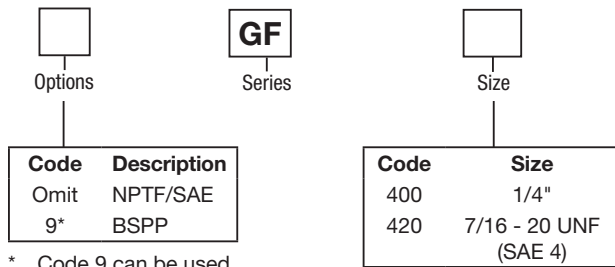

* Code 9 can be used with size 400.

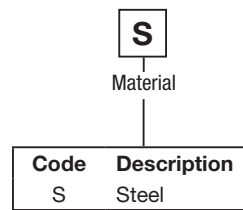

Design Series
 NOTE:
 Not required when ordering.

Weight: 0.6 kg (1.3 lbs.)

Dimensions

Inch equivalents for millimeter dimensions are shown in (**)

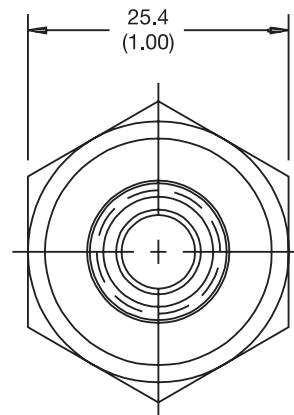
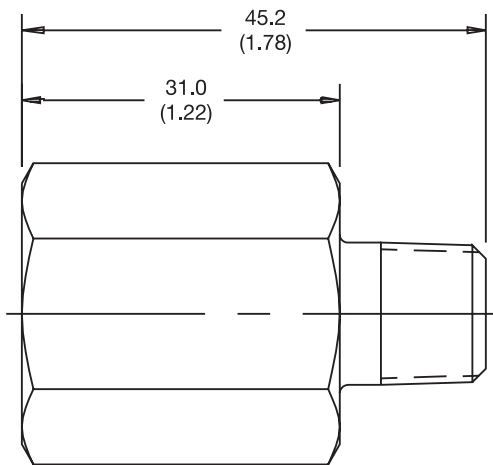

WARNING: This product can expose you to chemicals including Lead, Nickel (Metallic), or 1,3-Butadiene which are known to the State of California to cause cancer, and Lead or 1,3-Butadiene which is known to the State of California to cause birth defects and other reproductive harm. For more information go to www.P65Warnings.ca.gov.

Cat3300.indd, ddp, 09/22

General Description

Series GT valves isolate gauges from damage and inaccurate readings caused by line pressure surges and hydraulic hammer.

Operation

The GT has a push-to-read knob that delivers instant pressure to the gauge, yet isolates the gauge from the fluid line until the knob is pressed. When the knob is released, a spring-loaded spool closes instantly and drains all fluid from the gauge back into the reservoir.

Features

- Has a hardened steel spool.
- Partial snubbing action protects the gauge from surge damage.
- Optional panel mount.

Specifications

Maximum Operating Pressure	210 Bar (3000 PSI)
Mounting	In-line

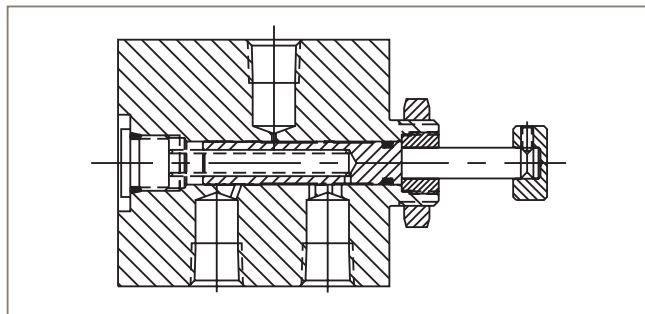
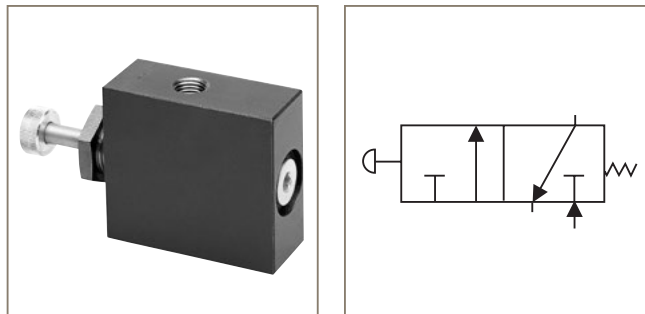

Ordering Information

<div style="border: 1px solid black; width: 20px; height: 20px; margin: 0 auto;"></div> <p>Options</p> <table border="1" style="margin-left: auto; margin-right: auto;"> <thead> <tr> <th>Code</th> <th>Description</th> </tr> </thead> <tbody> <tr> <td>Omit</td> <td>NPTF/SAE</td> </tr> <tr> <td>9*</td> <td>BSP</td> </tr> </tbody> </table>	Code	Description	Omit	NPTF/SAE	9*	BSP	<div style="border: 1px solid black; padding: 2px; width: 30px; height: 30px; display: flex; align-items: center; justify-content: center;"> GT </div> <p>Series</p>	<div style="border: 1px solid black; width: 20px; height: 20px; margin: 0 auto;"></div> <p>Size</p> <table border="1" style="margin-left: auto; margin-right: auto;"> <thead> <tr> <th>Code</th> <th>Size</th> </tr> </thead> <tbody> <tr> <td>400</td> <td>1/4"</td> </tr> <tr> <td>420</td> <td>7/16 - 20 UNF (SAE 4)</td> </tr> </tbody> </table>	Code	Size	400	1/4"	420	7/16 - 20 UNF (SAE 4)	<div style="border: 1px solid black; padding: 2px; width: 30px; height: 30px; display: flex; align-items: center; justify-content: center;"> S </div> <p>Material</p> <table border="1" style="margin-left: auto; margin-right: auto;"> <thead> <tr> <th>Code</th> <th>Description</th> </tr> </thead> <tbody> <tr> <td>S</td> <td>Steel</td> </tr> </tbody> </table>	Code	Description	S	Steel	<div style="border: 1px solid black; width: 20px; height: 20px; margin: 0 auto;"></div> <p>Seal Compound</p> <table border="1" style="margin-left: auto; margin-right: auto;"> <thead> <tr> <th>Code</th> <th>Description</th> </tr> </thead> <tbody> <tr> <td>Omit</td> <td>Nitrile (Standard)</td> </tr> <tr> <td>V</td> <td>Fluorocarbon</td> </tr> </tbody> </table>	Code	Description	Omit	Nitrile (Standard)	V	Fluorocarbon	<div style="border: 1px dashed black; width: 30px; height: 30px; margin: 0 auto;"></div> <p>Design Series</p> <p>NOTE: Not required when ordering.</p>
Code	Description																										
Omit	NPTF/SAE																										
9*	BSP																										
Code	Size																										
400	1/4"																										
420	7/16 - 20 UNF (SAE 4)																										
Code	Description																										
S	Steel																										
Code	Description																										
Omit	Nitrile (Standard)																										
V	Fluorocarbon																										

* Code 9 can be used with size 400.

Weight: 1.0 kg (2.2 lbs.)

Dimensions

Inch equivalents for millimeter dimensions are shown in (**)

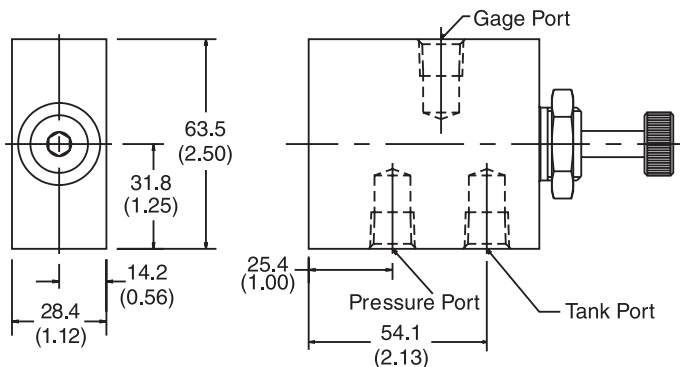
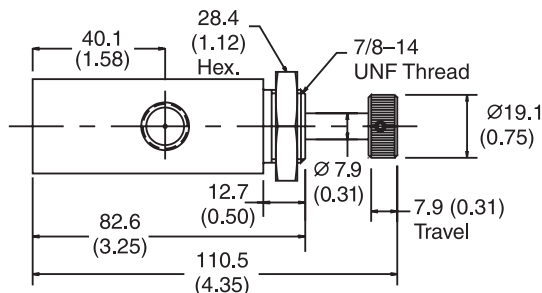

WARNING: This product can expose you to chemicals including Lead, Nickel (Metallic), or 1,3-Butadiene which are known to the State of California to cause cancer, and Lead or 1,3-Butadiene which is known to the State of California to cause birth defects and other reproductive harm. For more information go to www.P65Warnings.ca.gov.

Cat3300.indd, ddp, 09/22





High Pressure Ball Valves



ENGINEERING YOUR SUCCESS.

General Description

Series BVHP and BVAH are 2-way, bi-directional shut-off valves rated at 500 Bar (7250 PSI). A variety of porting options from 1/4" to 2" are available including threaded, SAE 4-bolt flange and split flange.

Operation

Parker's 2-way ball valves operate to either off or full flow by rotating the handle 90°. Ball valves are not designed to be a metering or flow control device.

Specifications

Maximum Pressure	BVHP04-08 steel & stainless steel: 500 Bar (7250 PSI) BVHP12 steel & stainless steel: 420 Bar (6000 PSI) BVHP16 steel & stainless steel: 500 Bar (7250 PSI) BVAH20-32 steel & stainless steel: 420 Bar (6000 PSI)
Body Material	Carbon Steel, ZnFe Plated 316Ti Stainless Steel
Ball Material	Steel, Chrome Plated 316 Stainless Steel, Chrome Plated
Stem Material	Steel, Zinc Plated 316 Stainless Steel, Chrome Plated
Standard Handle*	Steel Offset, Zn Plated
Standard Ball Seals	Delrin + MoS ₂
Standard Shaft Seals	Nitrile O-Ring, PTFE backup
Temperature Range with Standard Seals	-30°C to +100°C (-22°F to +212°F)

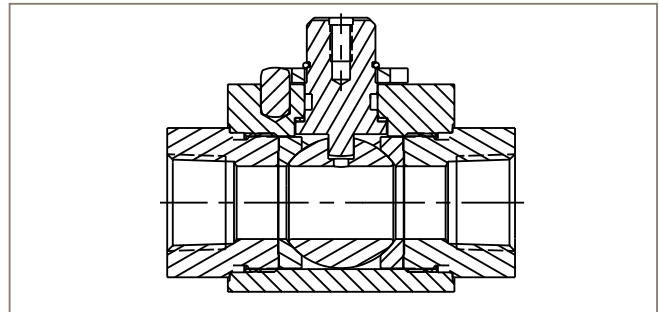
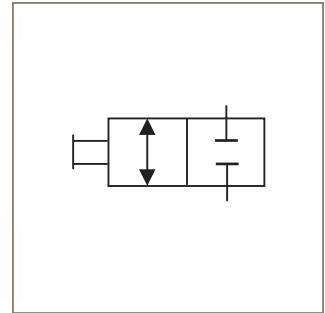

Features

- Thrust bearings and synthetic lubrication in the spindle results in one of the lowest torque requirements in the industry.
- A wide variety of porting options and mounting options make the BVHP and BVAH suitable for all mounting applications.
- Delrin seals with molybdenum disulphide (MoS₂) results in lower actuation torque and will increase high duty life cycle expectancy.
- The variety of spindle and ball sealing options make the BVHP and BVAH suitable for most media applications.
- Limit switch (LSB-20) is NEMA 4 with CSA/UL approval.

WARNING: This product can expose you to chemicals including Lead, Nickel (Metallic), or 1,3-Butadiene which are known to the State of California to cause cancer, and Lead or 1,3-Butadiene which is known to the State of California to cause birth defects and other reproductive harm. For more information go to www.P65Warnings.ca.gov.

Cat3300.indd, ddp, 09/22

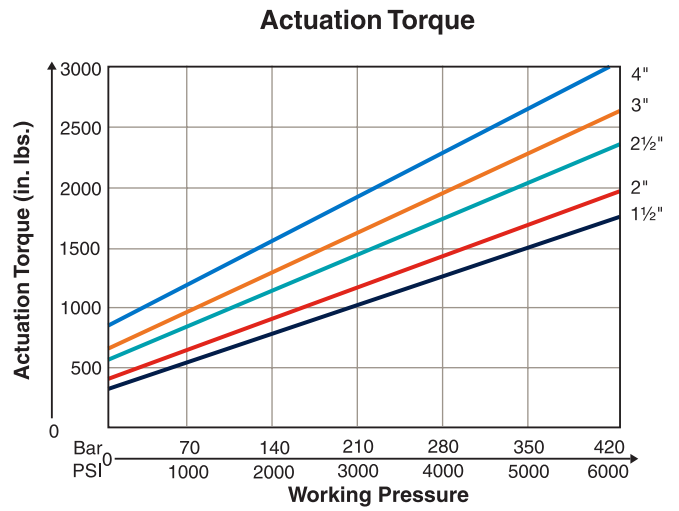
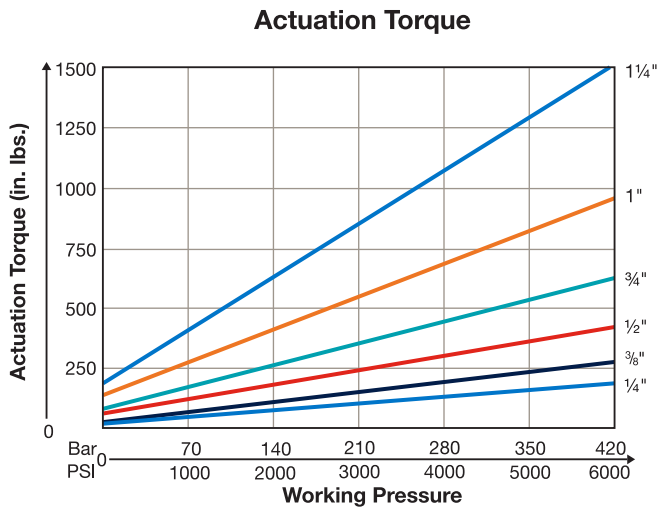
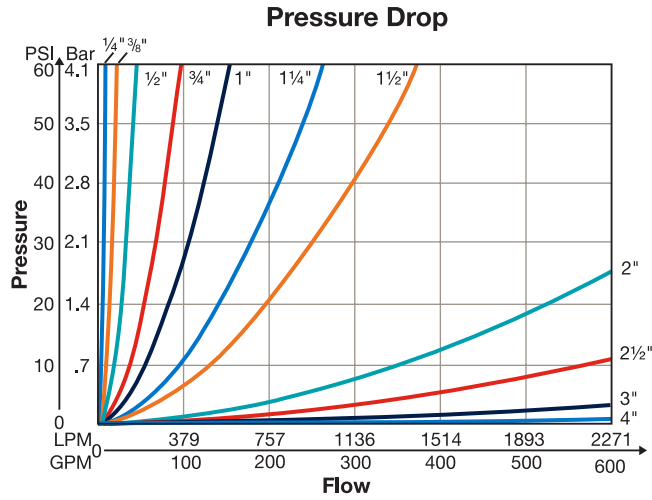

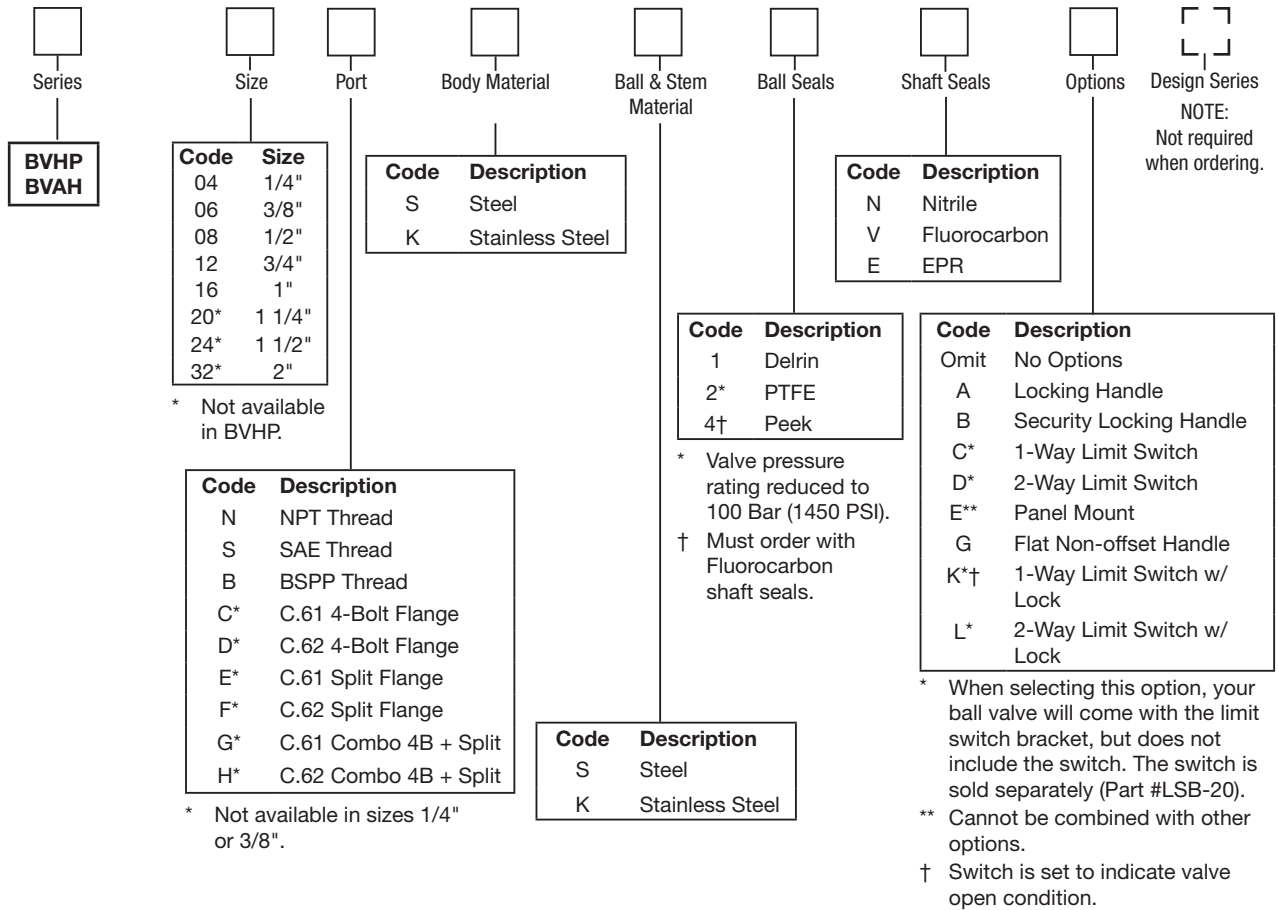

Weights in kg (lbs)

Size Code	Port Code									
	N	S	B	C*	D	E*	F	G*	H	
Steel										
04	0.4 (0.88)	0.4 (0.88)	0.4 (0.88)	N/A	N/A	N/A	N/A	N/A	N/A	N/A
06	0.6 (1.21)	0.5 (1.10)	0.5 (1.19)	N/A	N/A	N/A	N/A	N/A	N/A	N/A
08	0.8 (1.65)	0.7 (1.54)	0.7 (1.43)	1.5 (3.31)	1.5 (3.31)	0.9 (1.98)	0.9 (1.98)	1.2 (2.65)	1.2 (2.65)	1.2 (2.65)
12	1.6 (3.59)	1.6 (3.42)	1.5 (3.31)	3.0 (6.61)	2.8 (6.06)	1.9 (4.12)	2.0 (4.39)	2.2 (4.74)	2.3 (4.98)	2.3 (4.98)
16	3.2 (6.97)	3.1 (6.75)	3.1 (6.83)	4.5 (9.92)	4.5 (9.92)	2.7 (5.95)	3.7 (8.07)	3.6 (7.94)	3.8 (8.27)	3.8 (8.27)
20	3.5 (7.76)	3.5 (7.76)	3.5 (7.65)	7.5 (16.58)	7.5 (16.58)	4.2 (9.30)	4.7 (10.41)	5.9 (12.94)	6.1 (13.49)	6.1 (13.49)
24	5.7 (12.54)	5.7 (12.54)	5.7 (12.50)	11.1 (24.45)	11.1 (24.45)	6.5 (14.42)	7.5 (16.51)	8.8 (19.44)	9.3 (20.48)	9.3 (20.48)
32	8.1 (17.95)	8.0 (17.61)	8.1 (17.95)	19.3 (42.53)	19.3 (42.53)	9.3 (20.48)	11.4 (25.11)	14.3 (31.53)	15.3 (33.82)	15.3 (33.82)
Stainless Steel										
04	0.4 (0.88)	0.4 (0.88)	0.4 (0.88)	N/A	N/A	N/A	N/A	N/A	N/A	N/A
06	0.6 (1.21)	0.5 (1.10)	0.5 (1.19)	N/A	N/A	N/A	N/A	N/A	N/A	N/A
08	0.8 (1.65)	0.6 (1.21)	0.7 (1.43)	1.5 (3.31)	1.5 (3.31)	0.9 (1.87)	0.9 (1.87)	1.2 (2.65)	1.2 (2.65)	1.2 (2.65)
12	2.6 (5.73)	2.6 (5.73)	2.6 (5.73)	3.0 (6.61)	3.6 (7.91)	1.9 (4.12)	2.9 (6.28)	2.2 (4.74)	2.3 (4.98)	2.3 (4.98)
16	4.0 (8.82)	4.0 (8.82)	3.9 (8.69)	4.5 (9.92)	5.0 (11.09)	2.7 (5.95)	4.2 (9.30)	3.6 (7.94)	3.8 (8.27)	3.8 (8.27)
20	5.7 (12.61)	5.7 (12.61)	5.7 (12.61)	9.7 (21.43)	9.7 (21.43)	6.7 (14.84)	7.0 (15.43)	7.9 (17.33)	8.5 (18.76)	8.5 (18.76)
24	8.2 (17.99)	8.2 (17.99)	8.2 (17.99)	13.6 (29.92)	13.6 (29.92)	9.0 (19.86)	10.0 (21.96)	11.4 (25.20)	12.0 (26.35)	12.0 (26.35)
32	10.4 (22.86)	9.5 (20.88)	10.5 (23.04)	20.3 (44.64)	20.3 (44.64)	11.8 (26.01)	13.4 (29.52)	15.9 (34.94)	12.3 (27.16)	12.3 (27.16)

* C.61 Flange.

Threaded Ports – BVHP (Steel and Stainless Steel)

Inch equivalents for millimeter dimensions are shown in (**)

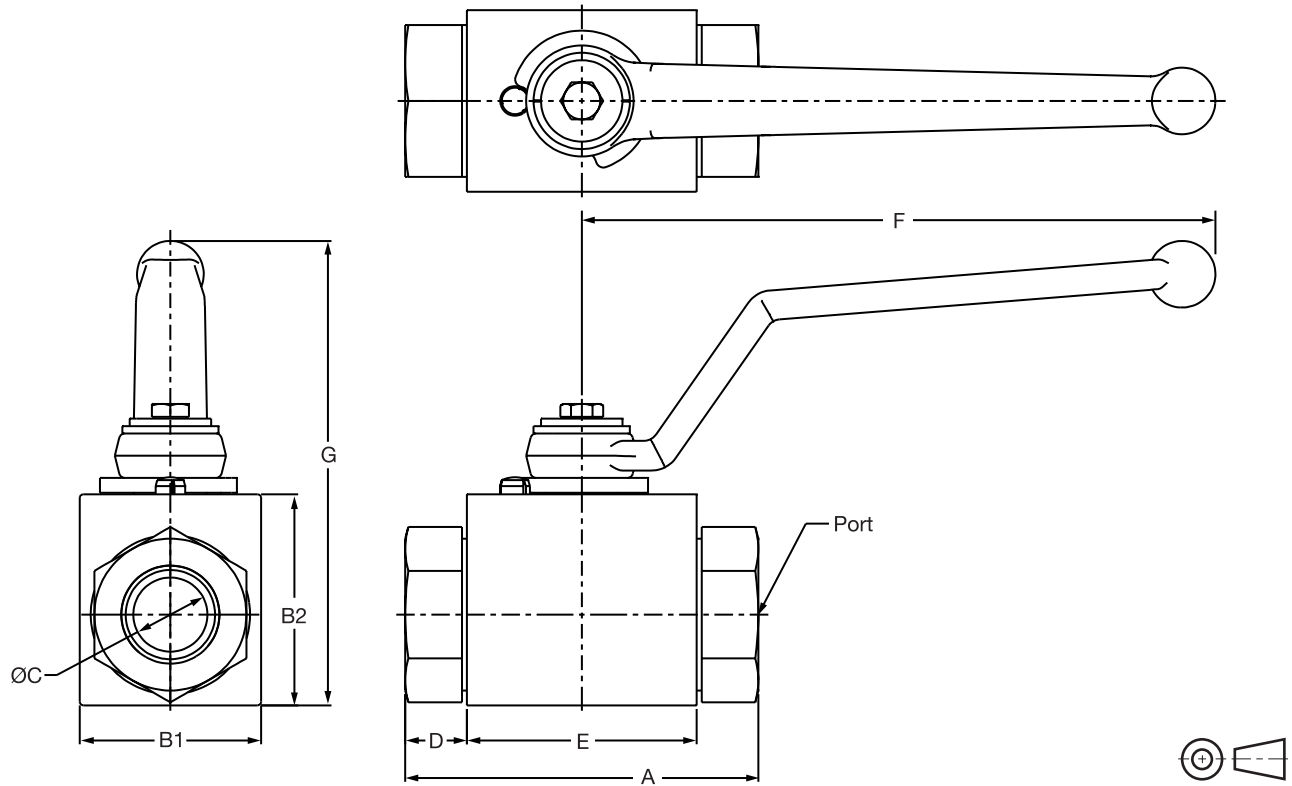

Code	Port Thread Size	Working Pressure	A	B1	B2	C	D	E	F	G
BVHP – NPT, SAE, and BSPP										
04	1/4"	500 Bar (7250 PSI)	69 (2.72)	26 (1.02)	33 (1.30)	6* (0.24)	14.5 (0.57)	40 (1.57)	115 (4.53)	84 (3.31)
06	3/8"	500 Bar (7250 PSI)	72** (2.83)	32 (1.26)	38 (1.50)	10 (0.39)	14.5 (0.57)	43 (1.69)	115 (4.53)	88 (3.46)
08	1/2"	500 Bar (7250 PSI)	83 (3.27)	35 (1.38)	40 (1.57)	13 (0.51)	17.5 (0.69)	48 (1.89)	115 (4.53)	91 (3.58)
12	3/4"	420 Bar (6000 PSI)	95 (3.74)	49 (1.93)	57 (2.24)	20 (0.79)	16.5 (0.65)	62 (2.44)	171 (6.73)	126 (4.96)
16	1"	500 Bar (7250 PSI)	113 (4.45)	70 (2.76)	70 (2.76)	25 (0.98)	19.5 (0.77)	74 (2.91)	171 (6.73)	139 (5.47)

* SAE dimension C for code 04 is 5 mm (0.20").

** SAE and BSPP dimensions for A for code 06 are 74 mm (2.91").

Threaded Ports – BVAH (Steel)

Inch equivalents for millimeter dimensions are shown in (**)

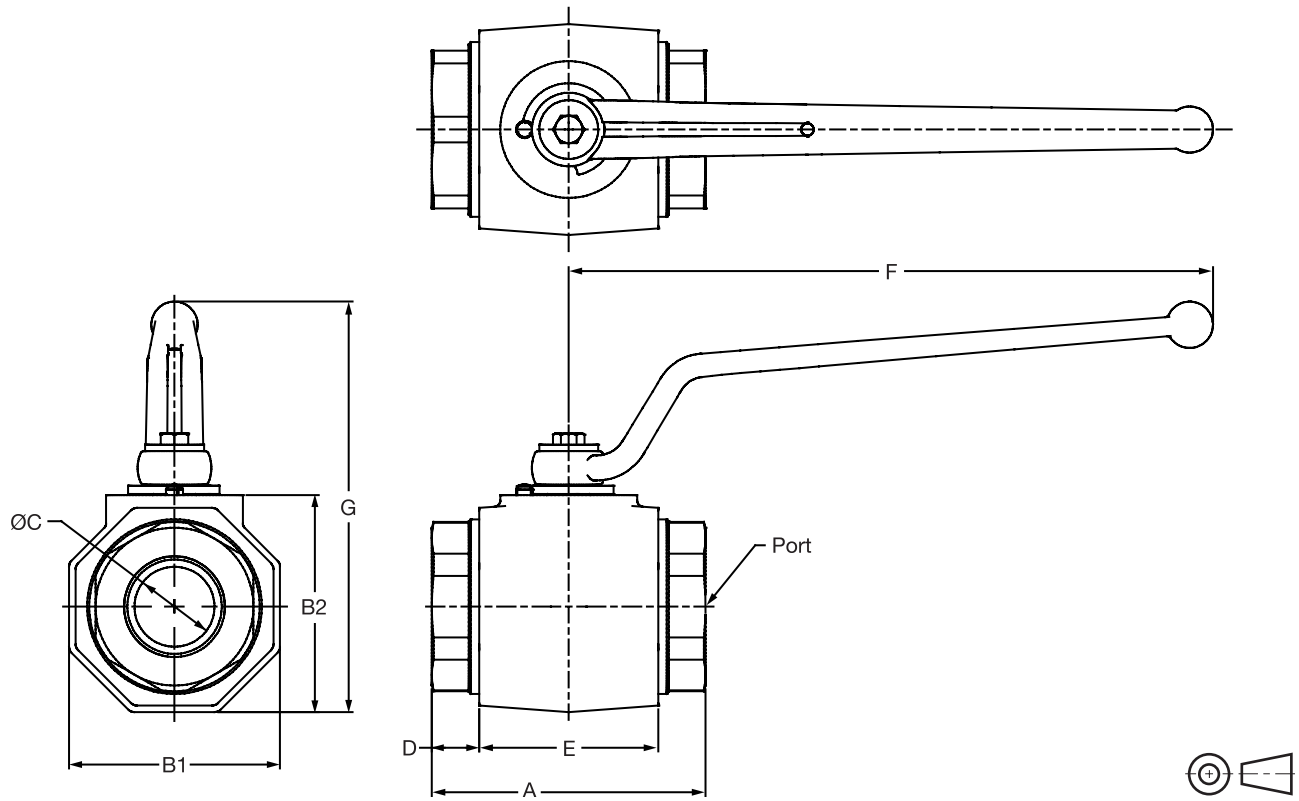

Code	Port Thread Size	Working Pressure	A	B1	B2	C	D	E	F	G
BVAH – NPT										
20	1 1/4"	420 Bar (6000 PSI)	120 (4.72)	81 (3.19)	86 (3.39)	32 (1.26)	40 (1.57)	80 (3.15)	306 (12.05)	177 (6.97)
24	1 1/2"	420 Bar (6000 PSI)	130 (5.12)	100 (3.94)	103 (4.06)	38 (1.50)	45 (1.77)	85 (3.35)	306 (12.05)	195 (7.68)
32	2"	420 Bar (6000 PSI)	140 (5.51)	118 (4.65)	117 (4.61)	48 (1.89)	40 (1.57)	100 (3.94)	306 (12.05)	209 (8.23)
BVAH – SAE										
20	1 1/4"	420 Bar (6000 PSI)	111 (4.37)	81 (3.19)	86 (3.39)	30 (1.18)	31 (1.22)	80 (3.15)	306 (12.05)	177 (6.97)
24	1 1/2"	420 Bar (6000 PSI)	130 (5.12)	100 (3.94)	103 (4.06)	38 (1.50)	45 (1.77)	85 (3.35)	306 (12.05)	195 (7.68)
32	2"	420 Bar (6000 PSI)	140 (5.51)	118 (4.65)	117 (4.61)	45 (1.77)	40 (1.57)	100 (3.94)	306 (12.05)	209 (8.23)
BVAH – BSPP										
20	1 1/4"	420 Bar (6000 PSI)	111 (4.37)	81 (3.19)	86 (3.39)	30 (1.18)	31 (1.22)	80 (3.15)	306 (12.05)	177 (6.97)
24	1 1/2"	420 Bar (6000 PSI)	130 (5.12)	100 (3.94)	103 (4.06)	38 (1.50)	45 (1.77)	85 (3.35)	306 (12.05)	195 (7.68)
32	2"	420 Bar (6000 PSI)	140 (5.51)	118 (4.65)	117 (4.61)	45 (1.77)	40 (1.57)	100 (3.94)	306 (12.05)	209 (8.23)

Threaded Ports – BVAH (Stainless Steel)

Inch equivalents for millimeter dimensions are shown in (**)

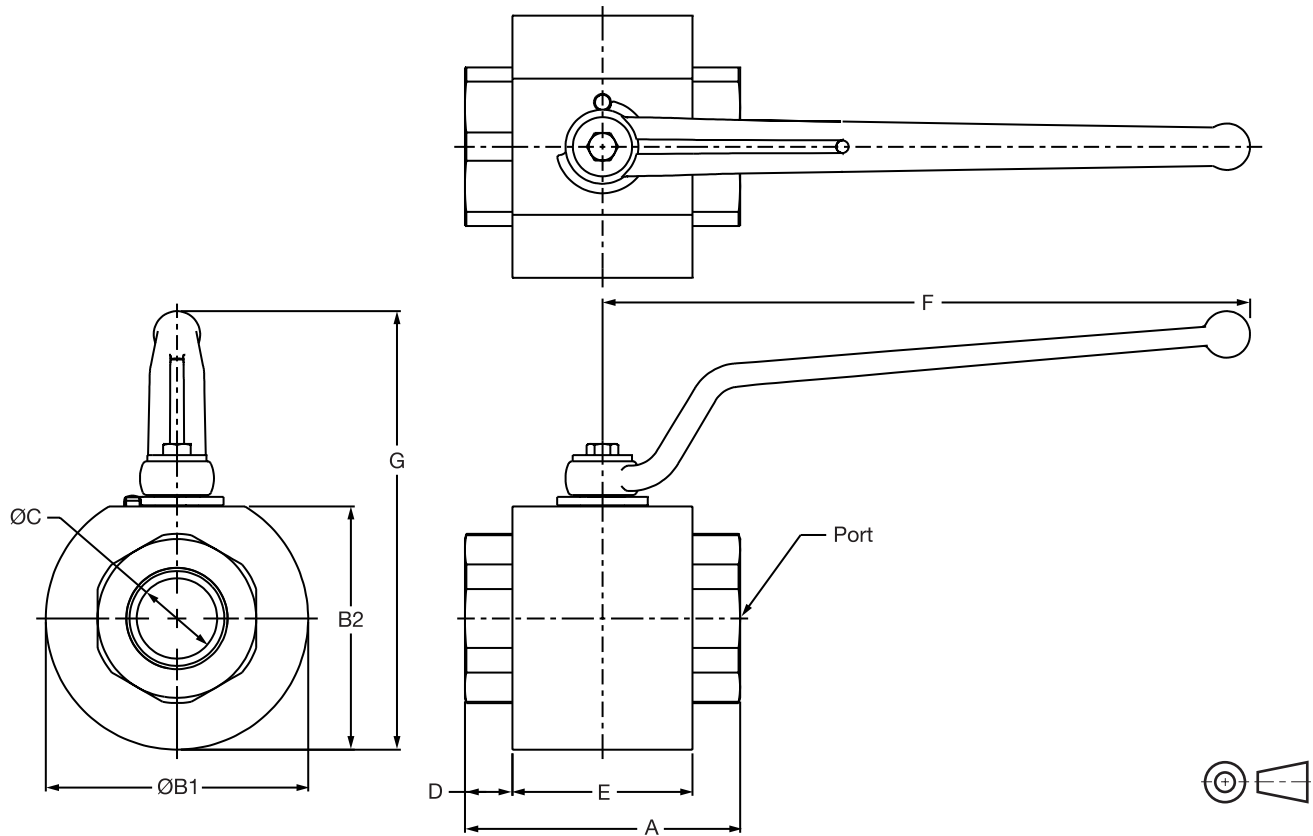

Code	Port Thread Size	Working Pressure	A	B1	B2	C	D	E	F	G
BVAH – NPT										
20	1 1/4"	420 Bar (6000 PSI)	120 (4.72)	109 (4.29)	100 (3.94)	32 (1.26)	40 (1.57)	80 (3.15)	306 (12.05)	192 (7.56)
24	1 1/2"	420 Bar (6000 PSI)	130 (5.12)	124 (4.88)	115 (4.53)	38 (1.50)	45 (1.77)	85 (3.35)	306 (12.05)	207 (8.15)
32	2"	420 Bar (6000 PSI)	140 (5.51)	132 (5.20)	124 (4.88)	48 (1.89)	39 (1.54)	101 (3.98)	306 (12.05)	217 (8.54)
BVAH – SAE										
20	1 1/4"	420 Bar (6000 PSI)	111 (4.37)	109 (4.29)	100 (3.94)	30 (1.18)	31 (1.22)	80 (3.15)	306 (12.05)	192 (7.56)
24	1 1/2"	420 Bar (6000 PSI)	130 (5.12)	124 (4.88)	115 (4.53)	38 (1.50)	45 (1.77)	85 (3.35)	306 (12.05)	207 (8.15)
32	2"	420 Bar (6000 PSI)	140 (5.51)	132 (5.20)	124 (4.88)	45 (1.77)	39 (1.54)	101 (3.98)	306 (12.05)	217 (8.54)
BVAH – BSPP										
20	1 1/4"	420 Bar (6000 PSI)	111 (4.37)	109 (4.29)	100 (3.94)	32 (1.26)	31 (1.22)	80 (3.15)	306 (12.05)	192 (7.56)
24	1 1/2"	420 Bar (6000 PSI)	130 (5.12)	124 (4.88)	115 (4.53)	38 (1.50)	45 (1.77)	85 (3.35)	306 (12.05)	207 (8.15)
32	2"	420 Bar (6000 PSI)	140 (5.51)	132 (5.20)	124 (4.88)	48 (1.89)	39 (1.54)	101 (3.98)	306 (12.05)	217 (8.54)

SAE 4-Bolt Flange – BVHP (Steel and Stainless Steel)

Inch equivalents for millimeter dimensions are shown in (**)

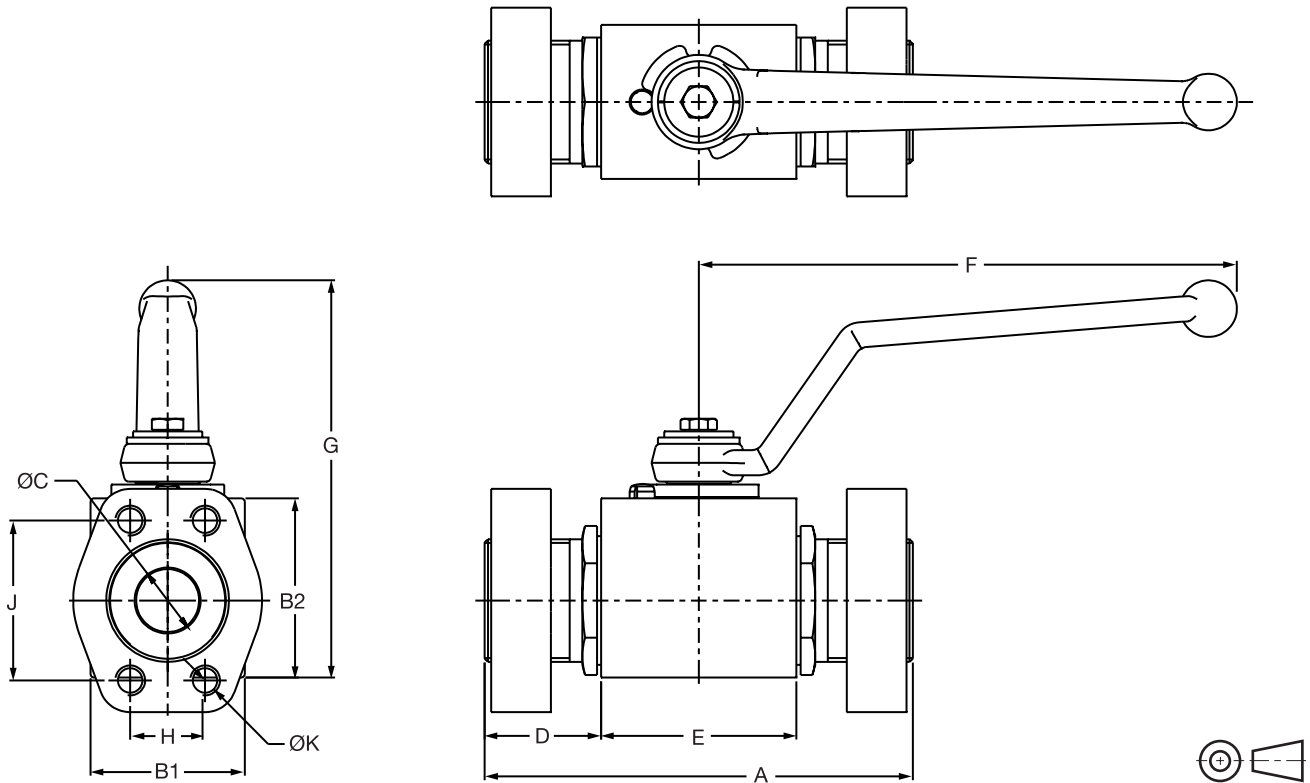

SAE 4-B Flange		Working Pressure	A	B1	B2	C	D	E	F	G	H	J	K
Code	Size												
BVHP – C.61 – SAE 4-Bolt Flange													
08	1/2"	350 Bar (5000 PSI)	120 (4.72)	35 (1.38)	40 (1.57)	13 (0.51)	36 (1.42)	48 (1.89)	115 (4.53)	91 (3.58)	17.5 (0.69)	38.1 (1.50)	5/16"-18
12	3/4"	350 Bar (5000 PSI)	136 (5.35)	49 (1.93)	57 (2.24)	20 (0.79)	37 (1.46)	62 (2.44)	171 (6.73)	126 (4.96)	22.2 (0.87)	47.6 (1.87)	3/8"-16
16	1"	350 Bar (5000 PSI)	148 (5.83)	58 (2.28)	65 (2.56)	25 (0.98)	41 (1.61)	66 (2.60)	171 (6.73)	139 (5.47)	26.2 (1.03)	52.4 (2.06)	3/8"-16
BVHP – C.62 – SAE 4-Bolt Flange													
08	1/2"	420 Bar (6000 PSI)	120 (4.72)	35 (1.38)	40 (1.57)	13 (0.51)	36 (1.42)	48 (1.89)	115 (4.53)	91 (3.58)	18.2 (0.72)	40.5 (1.59)	5/16"-18
12	3/4"	420 Bar (6000 PSI)	136 (5.35)	49 (1.93)	57 (2.24)	20 (0.79)	37 (1.46)	62 (2.44)	171 (6.73)	126 (4.96)	23.8 (0.94)	50.8 (2.00)	3/8"-16
16	1"	420 Bar (6000 PSI)	156 (6.14)	70 (2.76)	70 (2.76)	25 (0.98)	41 (1.61)	74 (2.91)	171 (6.73)	139 (5.47)	27.8 (1.09)	57.2 (2.25)	7/16"-14

SAE 4-Bolt Flange – BVAH (Steel)

Inch equivalents for millimeter dimensions are shown in (**)

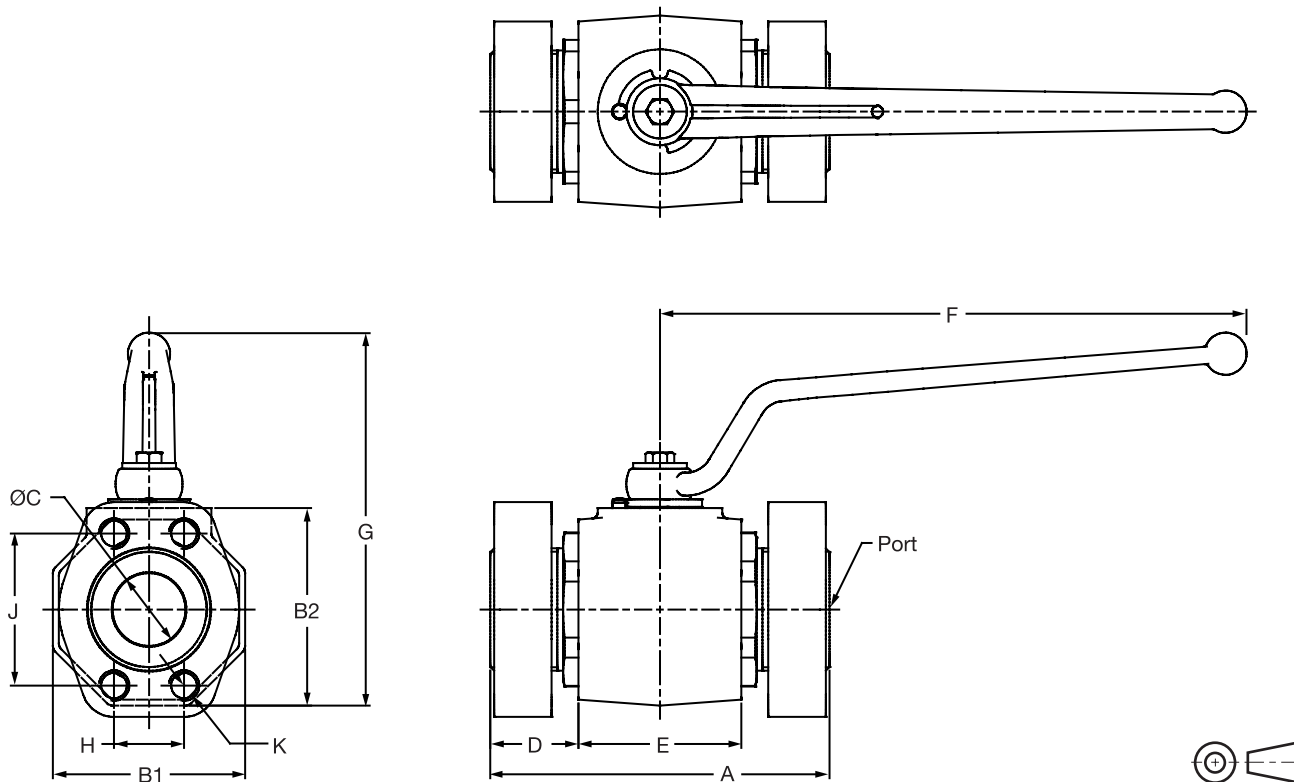

SAE 4-B Flange													
Code	Size	Working Pressure	A	B1	B2	C	D	E	F	G	H	J	K
BVAH – C.61 – SAE 4-Bolt Flange													
20	1 1/4"	280 Bar (4000 PSI)	172 (6.77)	81 (3.19)	86 (3.39)	32 (1.26)	46 (1.81)	80 (3.15)	306 (12.05)	180 (7.09)	30.2 (1.19)	58.7 (2.31)	7/16"-14
24	1 1/2"	210 Bar (3000 PSI)	177 (6.97)	100 (3.94)	103 (4.06)	38 (1.50)	46 (1.81)	85 (3.35)	306 (12.05)	197 (7.76)	35.7 (1.41)	69.9 (2.75)	1/2"-13
32	2"	210 Bar (3000 PSI)	196 (7.72)	118 (4.65)	117 (4.61)	48 (1.89)	48 (1.89)	100 (3.94)	306 (12.05)	211 (8.31)	42.9 (1.69)	77.8 (3.06)	1/2"-13
BVAH – C.62 – SAE 4-Bolt Flange													
20	1 1/4"	420 Bar (6000 PSI)	172 (6.77)	81 (3.19)	86 (3.39)	32 (1.26)	46 (1.81)	80 (3.15)	306 (12.05)	180 (7.09)	31.8 (1.25)	66.7 (2.63)	1/2"-13
24	1 1/2"	420 Bar (6000 PSI)	177 (6.97)	100 (3.94)	103 (4.06)	38 (1.50)	46 (1.81)	85 (3.35)	306 (12.05)	197 (7.76)	36.5 (1.44)	79.4 (3.13)	5/8"-11
32	2"	420 Bar (6000 PSI)	196 (7.72)	118 (4.65)	117 (4.61)	48 (1.89)	48 (1.89)	100 (3.94)	306 (12.05)	211 (8.31)	44.5 (1.75)	96.8 (3.81)	3/4"-10

SAE 4-Bolt Flange – BVAH (Stainless Steel)

Inch equivalents for millimeter dimensions are shown in (**)

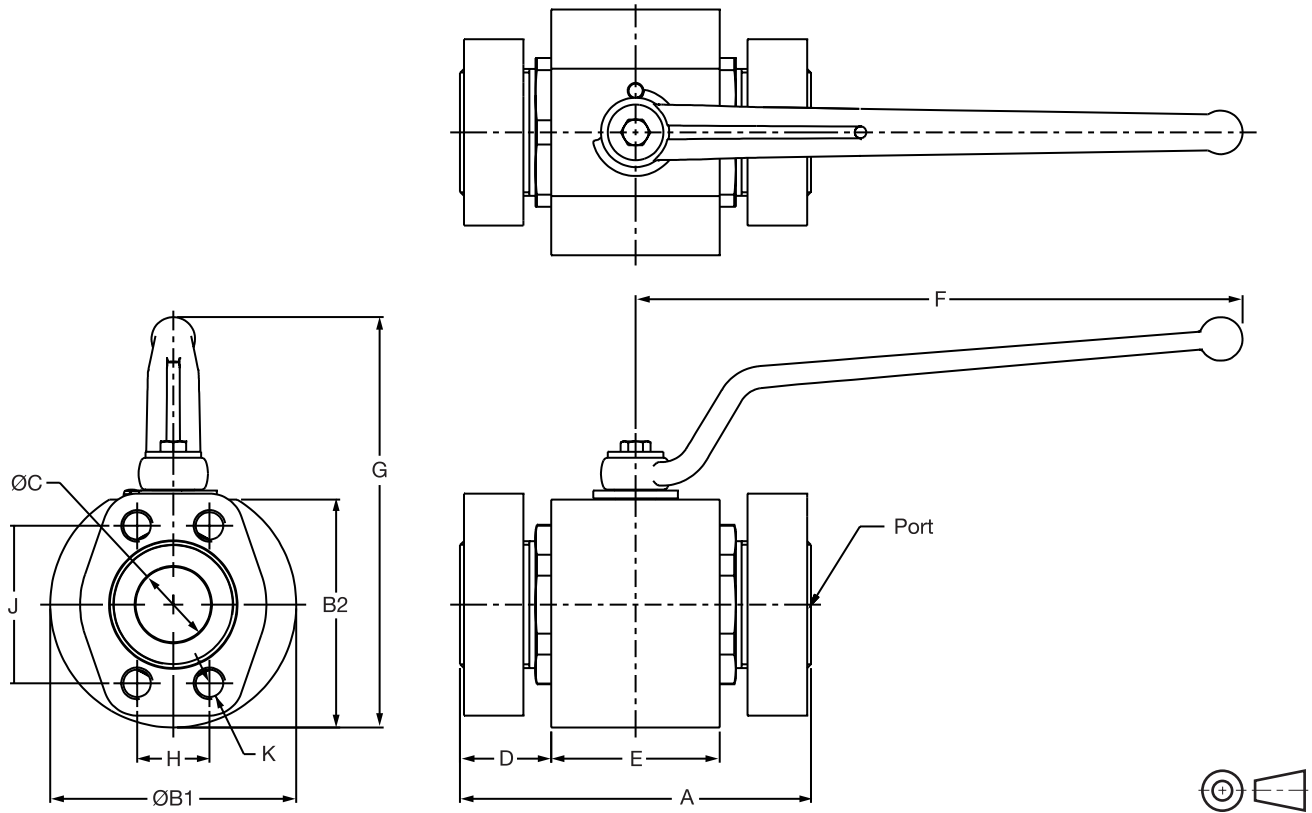

SAE 4-B Flange			Working Pressure	A	B1	B2	C	D	E	F	G	H	J	K
BVAH – C.61 – SAE 4-Bolt Flange														
20	1 1/4"	280 Bar (4000 PSI)	172 (6.77)	109 (4.29)	100 (3.94)	32 (1.26)	46 (1.81)	80 (3.15)	306 (12.05)	192 (7.56)	30.2 (1.19)	58.7 (2.31)	7/16"-14	
24	1 1/2"	210 Bar (3000 PSI)	177 (6.97)	124 (4.88)	115 (4.53)	38 (1.50)	46 (1.81)	85 (3.35)	306 (12.05)	207 (8.15)	35.7 (1.41)	69.9 (2.75)	1/2"-13	
32	2"	210 Bar (3000 PSI)	196 (7.72)	132 (5.20)	124 (4.88)	48 (1.89)	47.5 (1.87)	101 (3.98)	306 (12.05)	217 (8.54)	42.9 (1.69)	77.8 (3.06)	1/2"-13	
BVAH – C.62 – SAE 4-Bolt Flange														
20	1 1/4"	420 Bar (6000 PSI)	172 (6.77)	109 (4.29)	100 (3.94)	32 (1.26)	46 (1.81)	80 (3.15)	306 (12.05)	192 (7.56)	31.8 (1.25)	66.7 (2.63)	1/2"-13	
24	1 1/2"	420 Bar (6000 PSI)	177 (6.97)	124 (4.88)	115 (4.53)	38 (1.50)	46 (1.81)	85 (3.35)	306 (12.05)	207 (8.15)	36.5 (1.44)	79.4 (3.13)	5/8"-11	
32	2"	420 Bar (6000 PSI)	196 (7.72)	132 (5.20)	124 (4.88)	48 (1.89)	47.5 (1.87)	101 (3.98)	306 (12.05)	217 (8.54)	44.5 (1.75)	96.8 (3.81)	3/4"-10	

SAE Split Flange – BVHP (Steel and Stainless Steel)

Inch equivalents for millimeter dimensions are shown in (**)

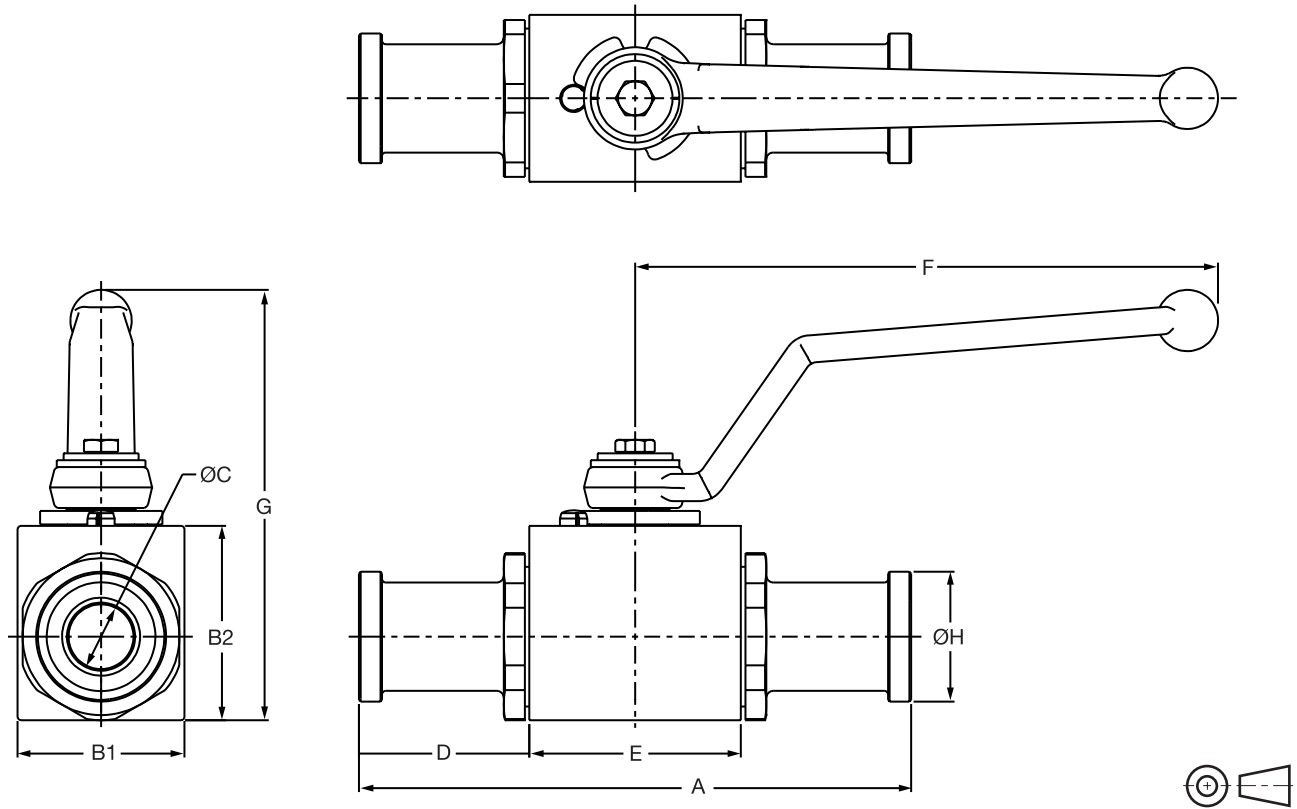

Code	Split Flange Size	Working Pressure*	A	B1	B2	C	D	E	F	G	H
BVHP – C.61 – SAE Split Flange											
08	1/2"	350 Bar (5000 PSI)	151 (5.94)	35 (1.38)	40 (1.57)	13 (0.51)	51.5 (2.03)	48 (1.89)	115 (4.53)	91 (3.58)	30.2 (1.19)
12	3/4"	350 Bar (5000 PSI)	162 (6.38)	49 (1.93)	57 (2.24)	19 (0.75)	50 (1.97)	62 (2.44)	171 (6.73)	126 (4.96)	38.1 (1.50)
16	1"	350 Bar (5000 PSI)	178 (7.01)	58 (2.28)	65 (2.56)	25 (0.98)	56 (2.20)	66 (2.60)	171 (6.73)	139 (5.47)	44.4 (1.75)
BVHP – C.62 – SAE Split Flange											
08	1/2"	420 Bar (6000 PSI)	151 (5.94)	35 (1.38)	40 (1.57)	13 (0.51)	51.5 (2.03)	48 (1.89)	115 (4.53)	91 (3.58)	31.8 (1.25)
12	3/4"	420 Bar (6000 PSI)	174 (6.85)	49 (1.93)	57 (2.24)	19 (0.75)	56 (2.20)	62 (2.44)	171 (6.73)	126 (4.96)	41.3 (1.63)
16	1"	420 Bar (6000 PSI)	206 (8.11)	70 (2.76)	70 (2.76)	25 (0.98)	66 (2.60)	74 (2.91)	171 (6.73)	139 (5.47)	47.6 (1.87)

SAE Split Flange – BVAH (Steel)

Inch equivalents for millimeter dimensions are shown in (**)

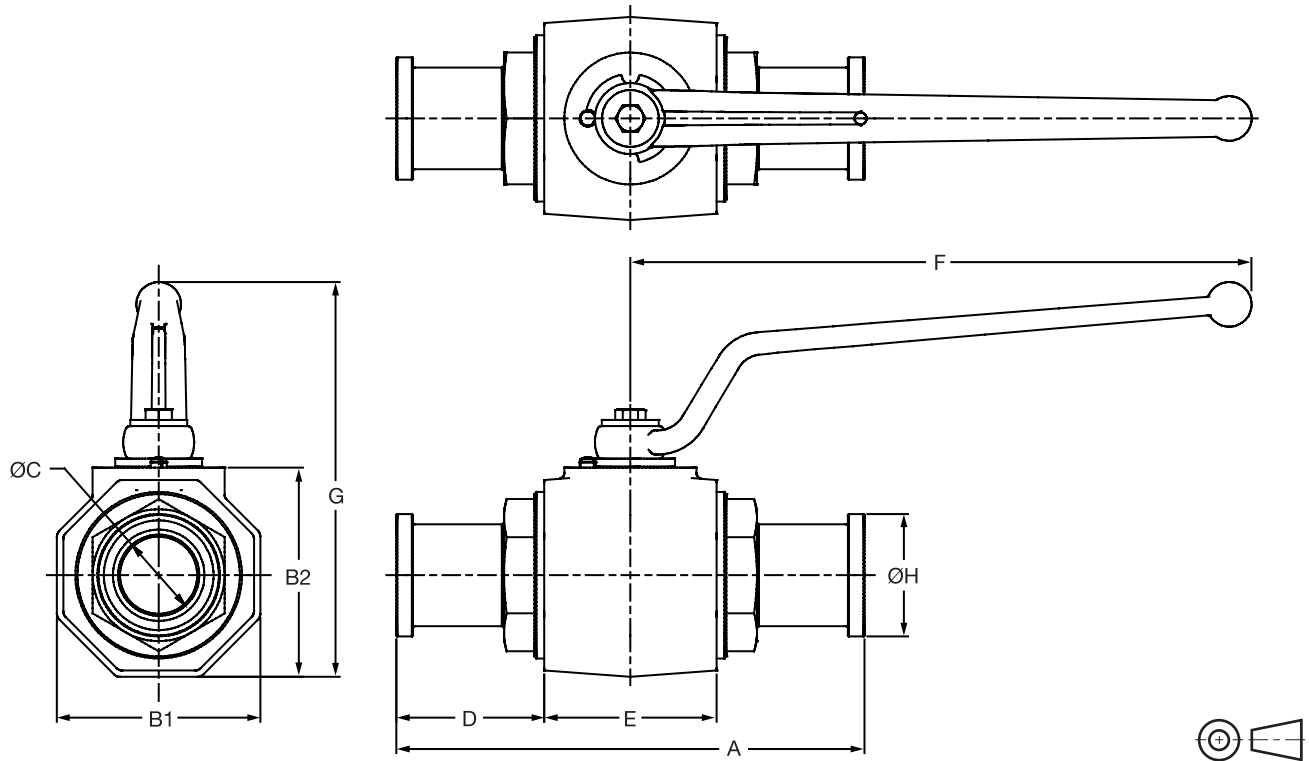

Code	Split Flange Size	Working Pressure	A	B1	B2	C	D	E	F	G	H
BVAH – C.61 – SAE Split Flange											
20	1 1/4"	280 Bar (4000 PSI)	191 (7.52)	81 (3.19)	86 (3.39)	30 (1.18)	55.5 (2.19)	80 (3.15)	306 (12.05)	180 (7.09)	50.8 (2.00)
24	1 1/2"	210 Bar (3000 PSI)	231 (9.09)	100 (3.94)	103 (4.06)	38 (1.50)	73 (2.87)	85 (3.35)	306 (12.05)	197 (7.76)	60.3 (2.37)
32	2"	210 Bar (3000 PSI)	232 (9.13)	118 (4.65)	117 (4.61)	48 (1.89)	66 (2.60)	100 (3.94)	306 (12.05)	211 (8.31)	71.4 (2.81)
BVAH – C.62 – SAE Split Flange											
20	1 1/4"	420 Bar (6000 PSI)	223 (8.78)	81 (3.19)	86 (3.39)	30 (1.18)	71.5 (2.81)	80 (3.15)	306 (12.05)	194 (7.64)	54.0 (2.13)
24	1 1/2"	420 Bar (6000 PSI)	281 (11.06)	100 (3.94)	103 (4.06)	38 (1.50)	98 (3.86)	85 (3.35)	306 (12.05)	209 (8.23)	63.5 (2.50)
32	2"	420 Bar (6000 PSI)	316 (12.44)	118 (4.65)	117 (4.61)	48 (1.89)	108 (4.25)	100 (3.94)	306 (12.05)	218 (8.58)	79.4 (3.13)

SAE Split Flange – BVAH (Stainless Steel)

Inch equivalents for millimeter dimensions are shown in (**)

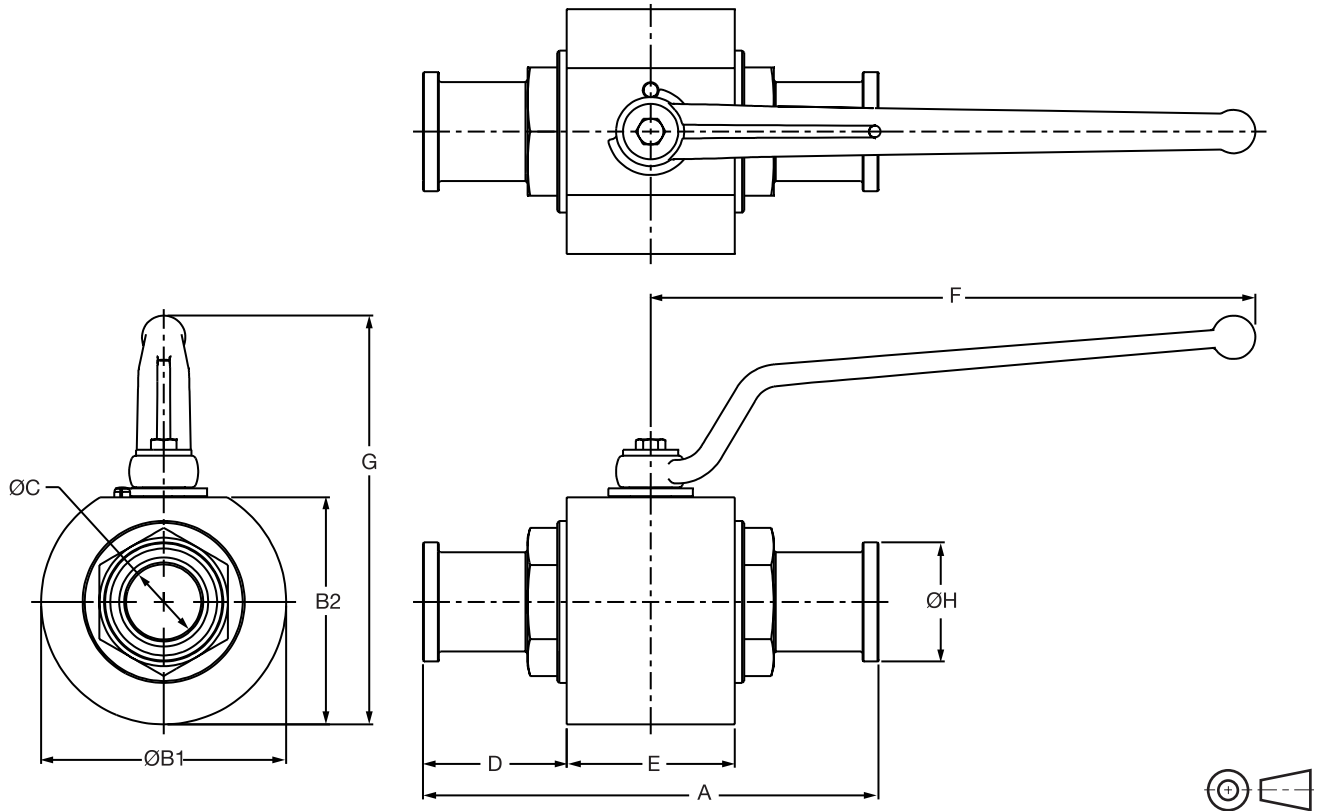

Code	SPLIT Flange Size	Working Pressure	A	B2	B2	C	D	E	F	G	H
BVAH – C.61 – SAE Split Flange											
20	1 1/4"	280 Bar (4000 PSI)	191 (7.52)	109 (4.29)	100 (3.94)	30 (1.18)	55.5 (2.19)	80 (3.15)	306 (12.05)	192 (7.56)	50.8 (2.00)
24	1 1/2"	210 Bar (3000 PSI)	231 (9.09)	124 (4.88)	115 (4.53)	38 (1.50)	73 (2.87)	85 (3.35)	306 (12.05)	207 (8.15)	60.3 (2.37)
32	2"	210 Bar (3000 PSI)	232 (9.13)	132 (5.20)	124 (4.88)	48 (1.89)	65.5 (2.58)	101 (3.98)	306 (12.05)	217 (8.54)	71.4 (2.81)
BVAH – C.62 – SAE Split Flange											
20	1 1/4"	420 Bar (6000 PSI)	223 (8.78)	109 (4.29)	100 (3.94)	30 (1.18)	71.5 (2.81)	80 (3.15)	306 (12.05)	192 (7.56)	54.0 (2.13)
24	1 1/2"	420 Bar (6000 PSI)	281 (11.06)	124 (4.88)	115 (4.53)	38 (1.50)	98 (3.86)	85 (3.35)	306 (12.05)	207 (8.15)	63.5 (2.50)
32	2"	420 Bar (6000 PSI)	316 (12.44)	132 (5.20)	124 (4.88)	48 (1.89)	107.5 (4.23)	101 (3.98)	306 (12.05)	217 (8.54)	79.4 (3.13)

Combination SAE 4-Bolt and SAE Split Flange – BVHP (Steel and Stainless Steel)

Inch equivalents for millimeter dimensions are shown in (**)

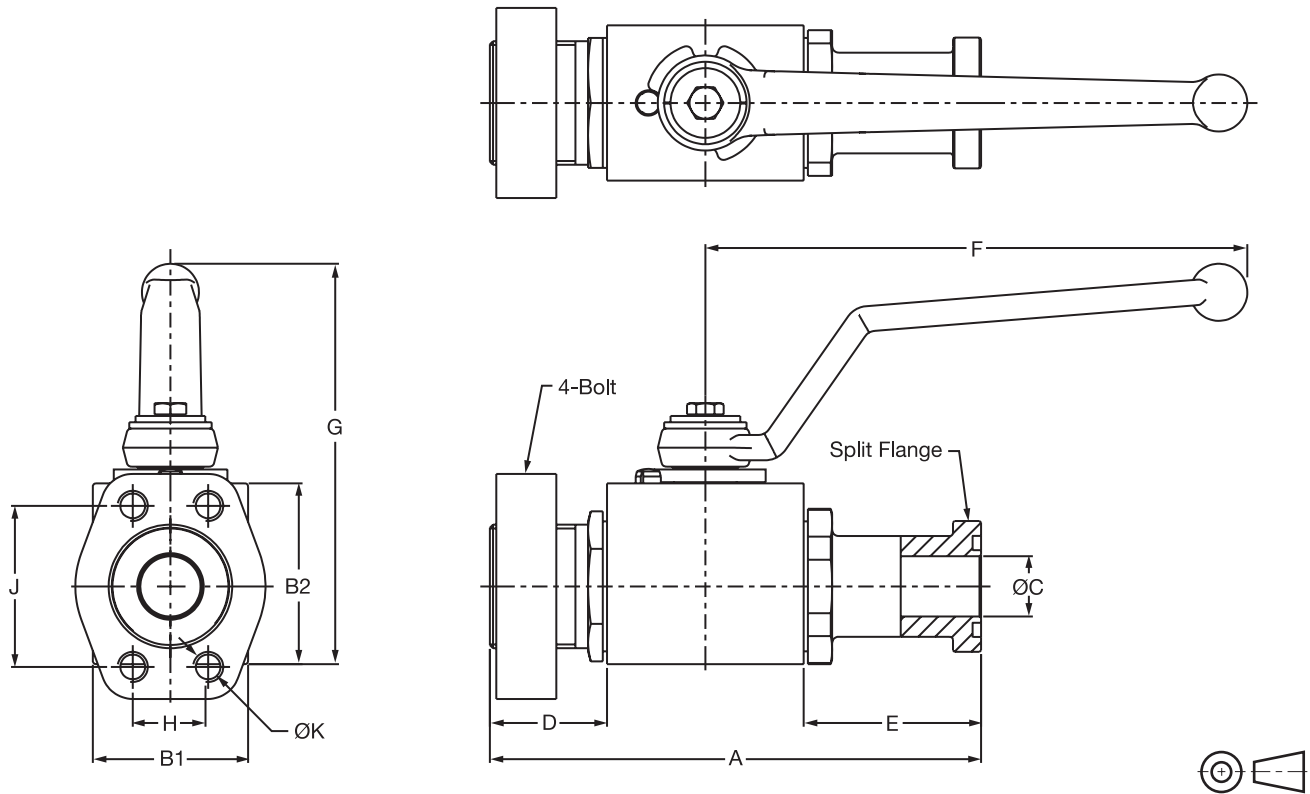

SAE 4-B Flange		Working Pressure	A	B1	B2	C	D	E	F	G	H	J	K
Code	Size												
BVHP – C.61 – SAE 4-Bolt and SAE Split Flange Combination													
08	1/2"	350 Bar (5000 PSI)	120.0 (4.72)	35.0 (1.38)	40.0 (1.57)	13.0 (0.51)	36.0 (1.42)	48.0 (1.89)	115.0 (4.53)	89.0 (3.50)	17.5 (0.69)	38.1 (1.50)	5/16"-18
12	3/4"	350 Bar (5000 PSI)	136.0 (5.35)	49.0 (1.93)	57.0 (2.24)	20.0 (0.79)	37.0 (1.46)	62.0 (2.44)	171.0 (6.73)	127.0 (5.00)	22.2 (0.87)	47.6 (1.87)	3/8"-16
16	1"	350 Bar (5000 PSI)	148.0 (5.83)	58.0 (2.28)	65.0 (2.56)	25.0 (0.98)	41.0 (1.61)	66.0 (2.60)	171.0 (6.73)	135.0 (5.31)	26.2 (1.03)	52.4 (2.06)	3/8"-16
BVHP – C.62 – SAE 4-Bolt and SAE Split Flange Combination													
08	1/2"	420 Bar (6000 PSI)	120.0 (4.72)	35.0 (1.38)	40.0 (1.57)	13.0 (0.51)	36.0 (1.42)	48.0 (1.89)	115.0 (4.53)	89.0 (3.50)	18.2 (0.72)	40.5 (1.59)	5/16"-18
12	3/4"	420 Bar (6000 PSI)	136.0 (5.35)	49.0 (1.93)	57.0 (2.24)	20.0 (0.79)	37.0 (1.46)	62.0 (2.44)	171.0 (6.73)	127.0 (5.00)	23.8 (0.94)	50.8 (2.00)	3/8"-16
16	1"	420 Bar (6000 PSI)	148.0 (5.83)	70.0 (2.76)	70.0 (2.76)	25.0 (0.98)	41.0 (1.61)	74.0 (2.91)	171.0 (6.73)	140.0 (5.51)	27.8 (1.09)	57.2 (2.25)	7/16"-14

Combination SAE 4-Bolt and SAE Split Flange – BVAH (Steel)

Inch equivalents for millimeter dimensions are shown in (**)

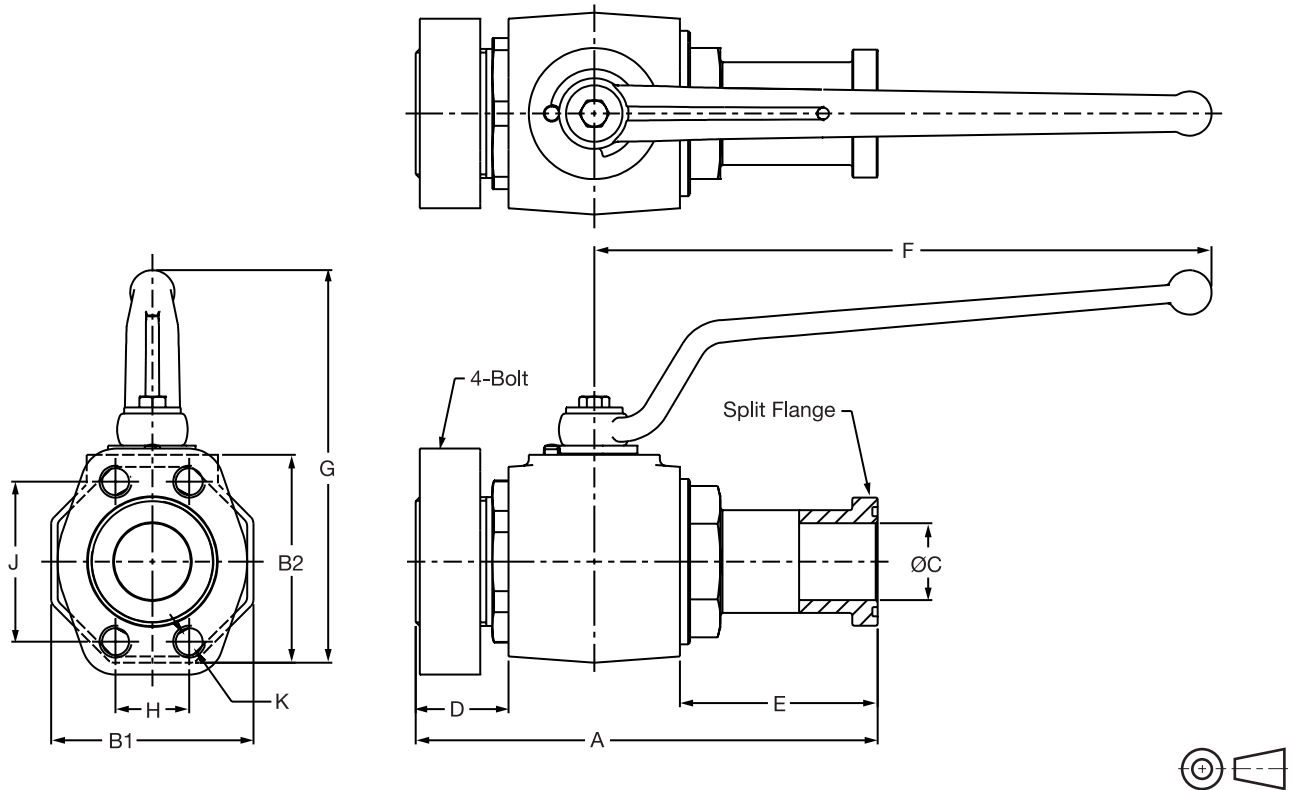

Code	SAE Flange Size	Working Pressure	A	B1	B2	C	D	E	F	G	H	J	K
BVAH – C.61 – SAE 4-Bolt and SAE Split Flange Combination													
20	1 1/4"	280 Bar (4000 PSI)	181 (7.13)	81 (3.16)	86 (3.39)	30 (1.18)	46 (1.81)	51.5 (2.03)	306 (12.05)	180 (7.09)	30.2 (1.19)	58.7 (2.31)	7/16"-14
24	1 1/2"	210 Bar (3000 PSI)	204 (8.03)	100 (3.94)	103 (4.06)	38 (1.50)	46 (1.81)	50 (1.97)	306 (12.05)	197 (7.76)	35.7 (1.41)	69.9 (2.75)	1/2"-13
32	2"	210 Bar (3000 PSI)	214 (8.43)	118 (4.65)	117 (4.61)	48 (1.89)	48 (1.89)	56 (2.20)	306 (12.05)	211 (8.31)	42.9 (1.69)	77.8 (3.06)	1/2"-13
BVAH – C.62 – SAE 4-Bolt Flange													
20	1 1/4"	420 Bar (6000 PSI)	198 (7.80)	81 (3.19)	86 (3.39)	30 (1.18)	46 (1.81)	51.5 (2.03)	306 (12.05)	180 (7.09)	31.8 (1.25)	66.7 (2.63)	1/2"-13
24	1 1/2"	420 Bar (6000 PSI)	229 (9.02)	100 (3.94)	103 (4.06)	38 (1.50)	46 (1.81)	56 (2.20)	306 (12.05)	197 (7.76)	36.5 (1.44)	79.4 (3.13)	5/8"-11
32	2"	420 Bar (6000 PSI)	256 (10.08)	118 (4.65)	117 (4.61)	48 (1.89)	48 (1.89)	66 (2.60)	306 (12.05)	211 (8.31)	44.5 (1.75)	96.8 (3.81)	3/4"-10

Combination SAE 4-Bolt and SAE Split Flange – BVAH (Stainless Steel)

Inch equivalents for millimeter dimensions are shown in (**)

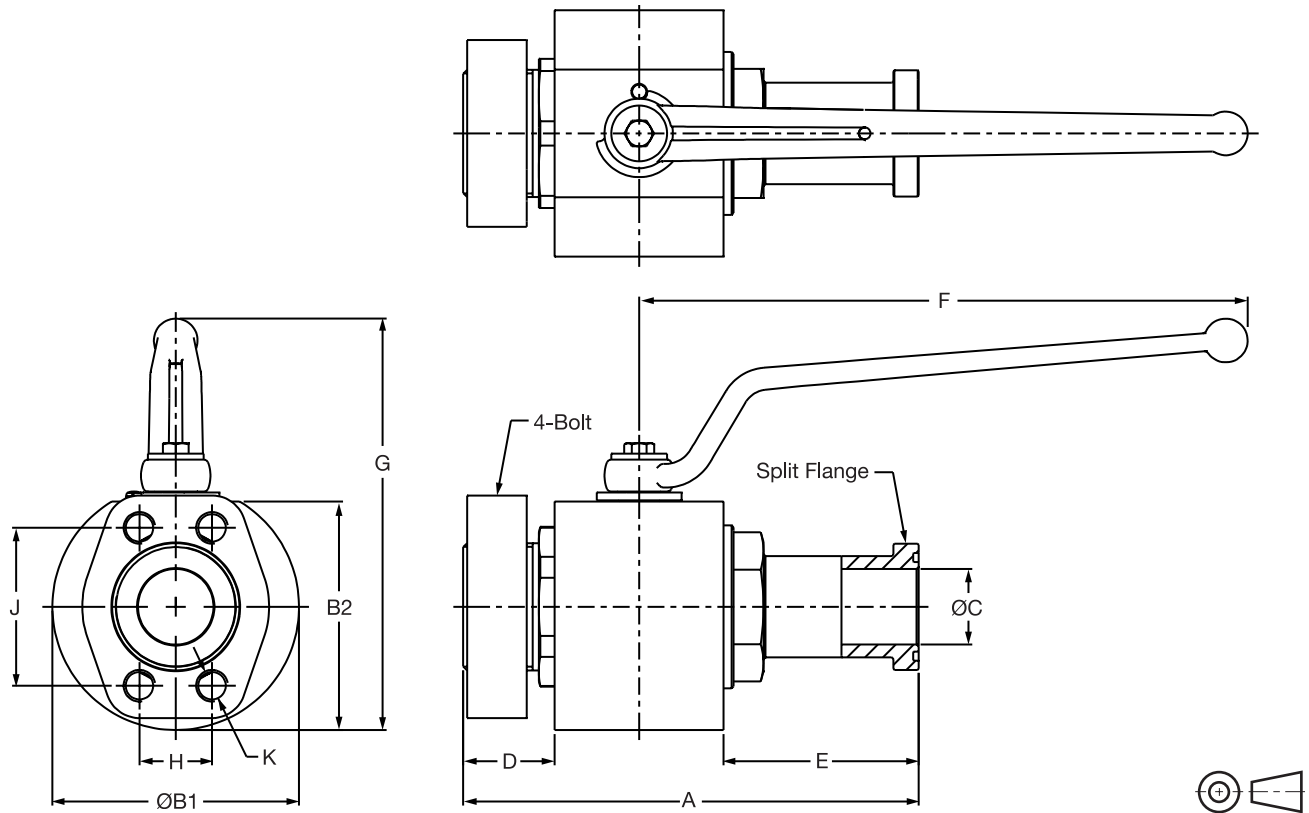

Code	SAE Flange Size	Working Pressure	A	B1	B2	C	D	E	F	G	H	J	K
BVAH – C.61 – SAE 4-Bolt and SAE Split Flange Combination													
20	1 1/4"	280 Bar (4000 PSI)	181 (7.13)	109 (4.29)	100 (3.94)	30 (1.18)	46 (1.81)	51.5 (2.03)	306 (12.05)	194 (7.64)	30.2 (1.19)	58.7 (2.31)	7/16"-14
24	1 1/2"	210 Bar (3000 PSI)	204 (8.03)	124 (4.88)	115 (4.53)	38 (1.50)	46 (1.81)	50 (1.97)	306 (12.05)	209 (8.23)	35.7 (1.41)	69.9 (2.75)	1/2"-13
32	2"	210 Bar (3000 PSI)	214 (8.43)	132 (5.20)	124 (4.88)	48 (1.89)	48 (1.89)	56 (2.20)	306 (12.05)	218 (8.58)	42.9 (1.69)	77.8 (3.06)	1/2"-13
BVAH – C.62 – SAE 4-Bolt and SAE Split Flange Combination													
20	1 1/4"	420 Bar (6000 PSI)	198 (7.80)	109 (4.29)	100 (3.94)	30 (1.18)	46 (1.81)	51.5 (2.03)	306 (12.05)	194 (7.64)	31.8 (1.25)	66.7 (2.63)	1/2"-13
24	1 1/2"	420 Bar (6000 PSI)	229 (9.02)	124 (4.88)	115 (4.53)	38 (1.50)	46 (1.81)	56 (2.20)	306 (12.05)	209 (8.23)	36.5 (1.44)	79.4 (3.13)	5/8"-11
32	2"	420 Bar (6000 PSI)	256 (10.08)	132 (5.20)	124 (4.88)	48 (1.89)	48 (1.89)	66 (2.60)	306 (12.05)	218 (8.58)	44.5 (1.75)	96.8 (3.81)	3/4"-10

Ball Valve Seal Kits restore a ball valve to factory specifications, providing no erosion or metal-to-metal wear has taken place.

The Seal Kit includes all the o-rings, ball seals and thrust bearings that were originally installed at the factory.

Ordering Information

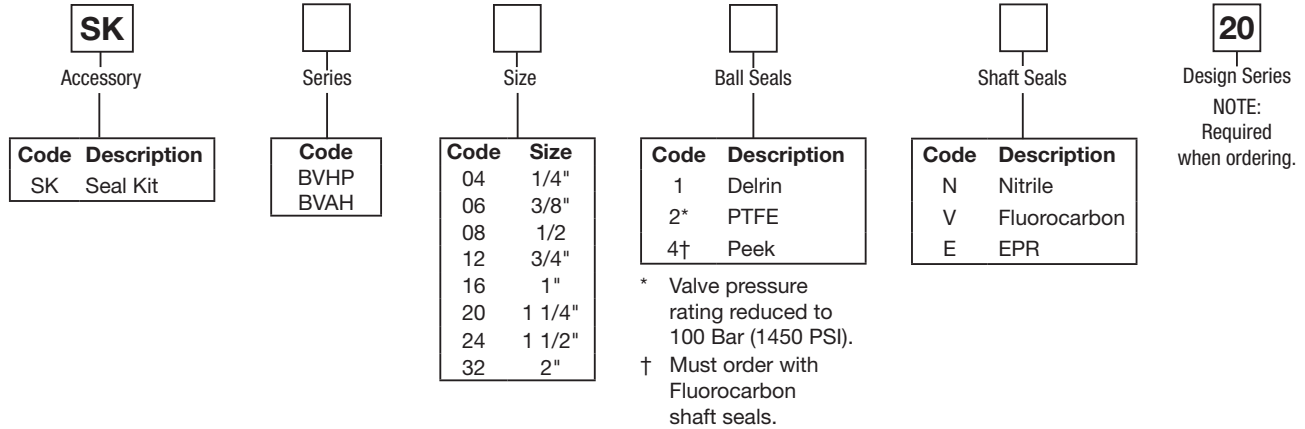

**Replacement Handles
 Standard Steel Offset**

Series	Part Number
BVHP04	BVH-HS1-20
BVHP06	BVH-HS1-20
BVHP08	BVH-HS1-20
BVHP12	BVH-HS2-20
BVHP16	BVH-HS2-20
BVAH20	BVH-HS3-20
BVAH24	BVH-HS3-20
BVAH32	BVH-HS3-20

BVHPLK: Standard Series 'BVHPLK-*-**' kit replaces the stopwasher with a stationary and moving plate, as illustrated below. As the handle is actuated, the moving plate aligns with one of the two locking positions in the stationary plate, enabling the valve to be locked in either **fully closed** or **fully open** position.

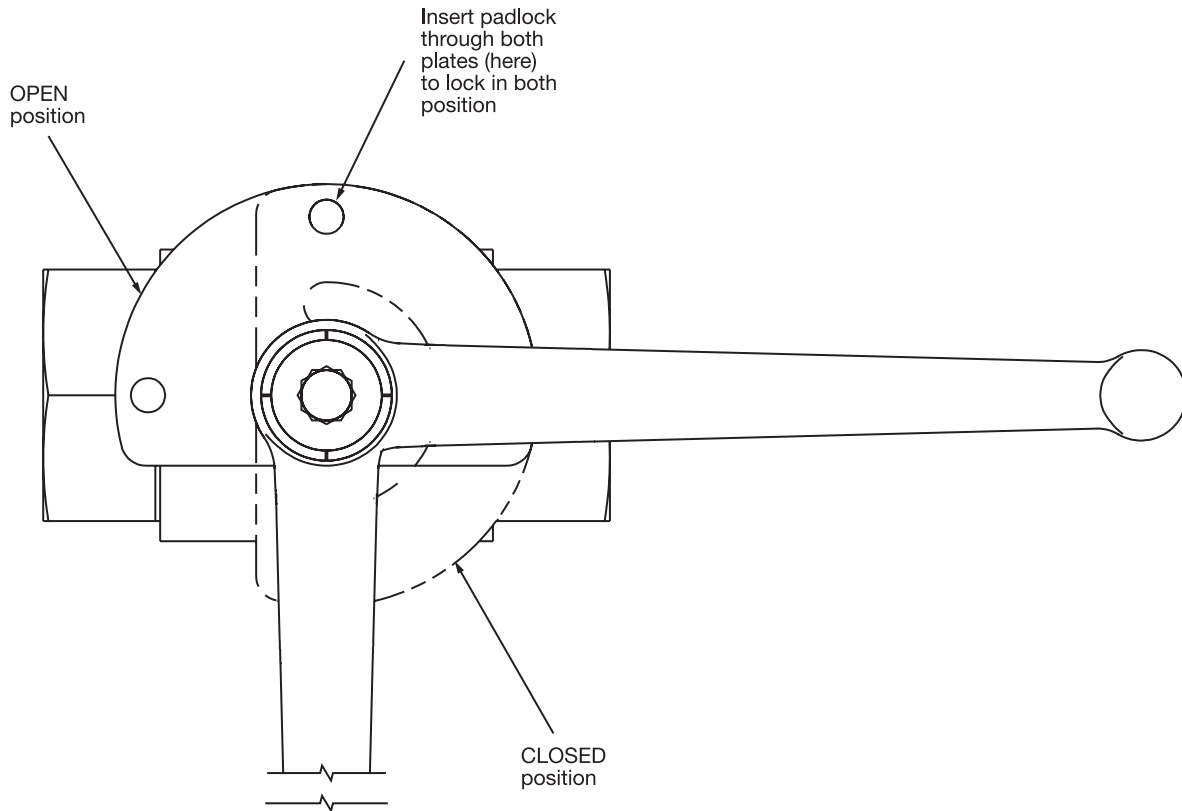

Ordering Information

BVHP, BVAH Code	Size	Standard Locking (Part Number)
04	1/4"	BVHPLK-1-20
06	3/8"	BVHPLK-1-20
08	1/2"	BVHPLK-1-20
12	3/4"	BVHPLK-2-20
16	1"	BVHPLK-2-20
20	1 1/4"	BVHPLK-3-20
24	1 1/2"	BVHPLK-3-20
32	2"	BVHPLK-3-20

General Description

Series BVHH valves are used for shut-off applications and are rated at 800 Bar (11,600 PSI). These valves represent the strongest ball valve in the industry. Series BVHH valves are available in sizes 1/4" to 2" with NPT, BSPP, or DIN 2353 heavy series ports. SAE ports are not available (obsolete).

Operation

Parker's 2-way ball valves operate to either off or full flow by rotating the handle 90°. Ball valves are not designed to be a metering or flow control device.

Specifications

Maximum Pressure	800 Bar (11,600 PSI)
Body Material	Steel, ZnFe Plated
Ball Material	Steel, Chrome Plated 316 Stainless Steel
Stem Material	Steel, Zinc Plated 316 Stainless Steel
Standard Handle	Steel Offset, Zinc Plated
Standard Ball Seals	Delrin + MoS ₂
Standard Shaft Seals	Nitrile O-Ring, PTFE backup
Temperature Range with Standard Seals	-30°C to +100°C (-22°F to +212°F)

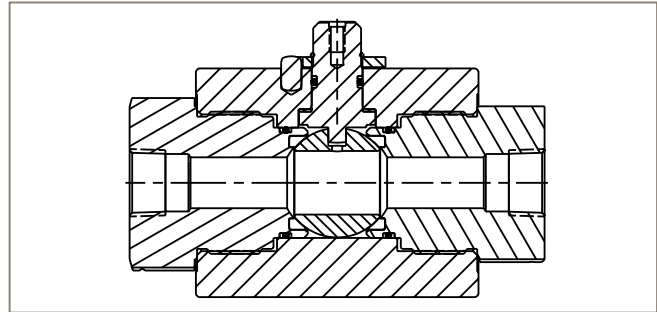
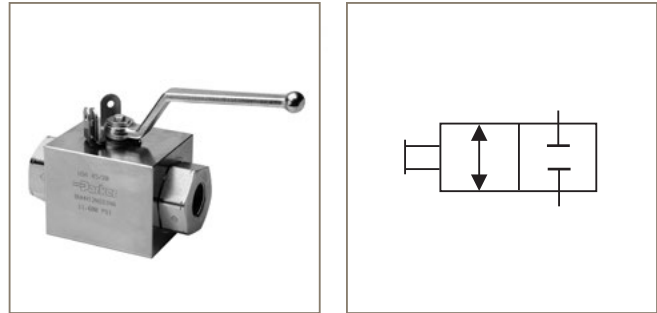

Features

- The BVHH is fully ported resulting in very low pressure drop.
- Nitrile seals are standard with fluorocarbon and EPR as options.
- The BVHH is available with options found in the 420 Bar (6000 PSI) models.

Performance Curves

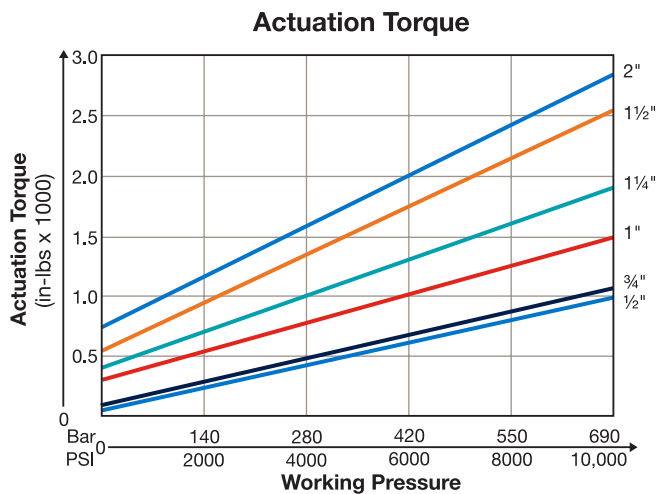
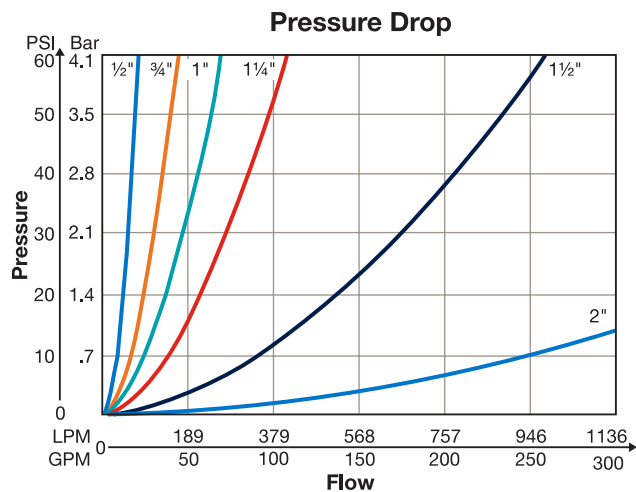

WARNING: This product can expose you to chemicals including Lead, Nickel (Metallic), or 1,3-Butadiene which are known to the State of California to cause cancer, and Lead or 1,3-Butadiene which is known to the State of California to cause birth defects and other reproductive harm. For more information go to www.P65Warnings.ca.gov.

Cat3300.indd, ddp, 09/22

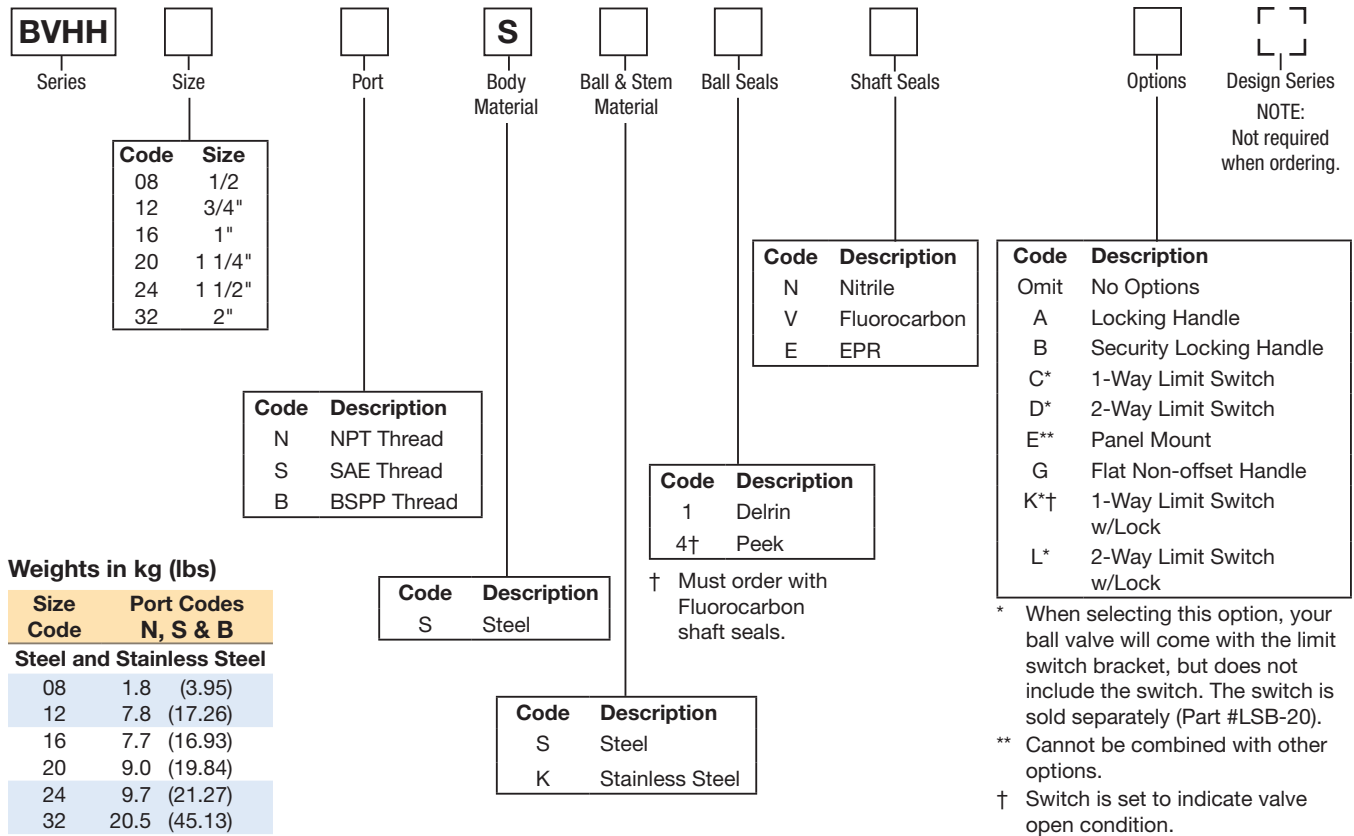

Seal Kit Accessories

Ball Valve Seal Kits restore a ball valve to factory specifications, providing no erosion or metal-to-metal wear has taken place.

The Seal Kit includes all the o-rings, ball seals and thrust bearings that were originally installed at the factory. A sketch of these parts is provided at the right.

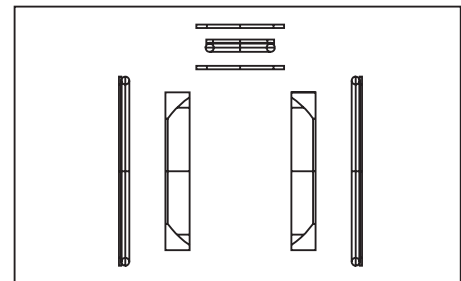

Ordering Information

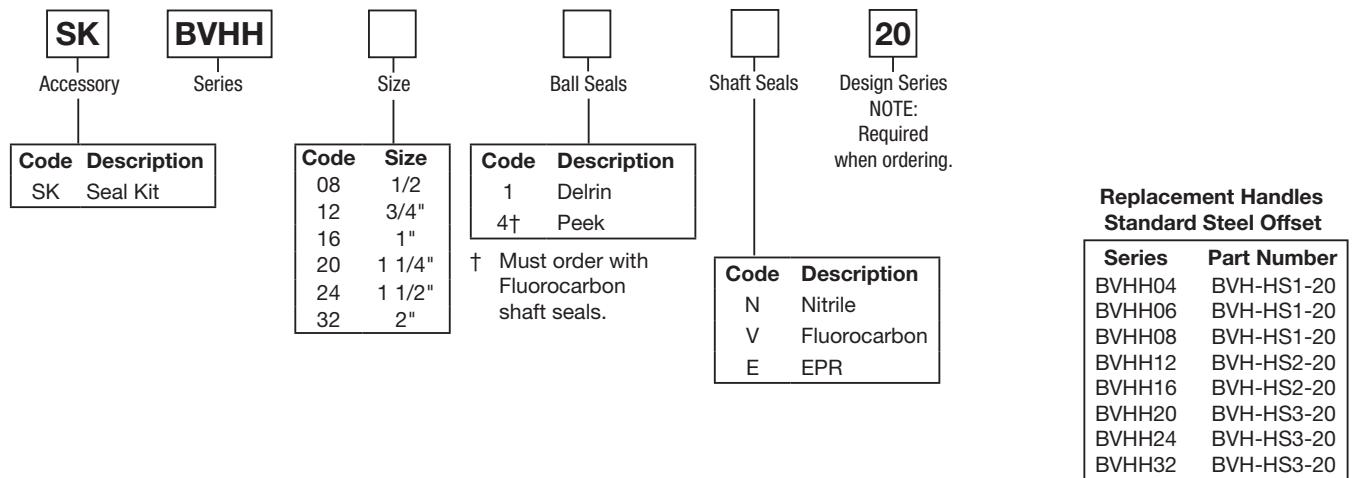

Threaded Ports (Steel)

Inch equivalents for millimeter dimensions are shown in (**)

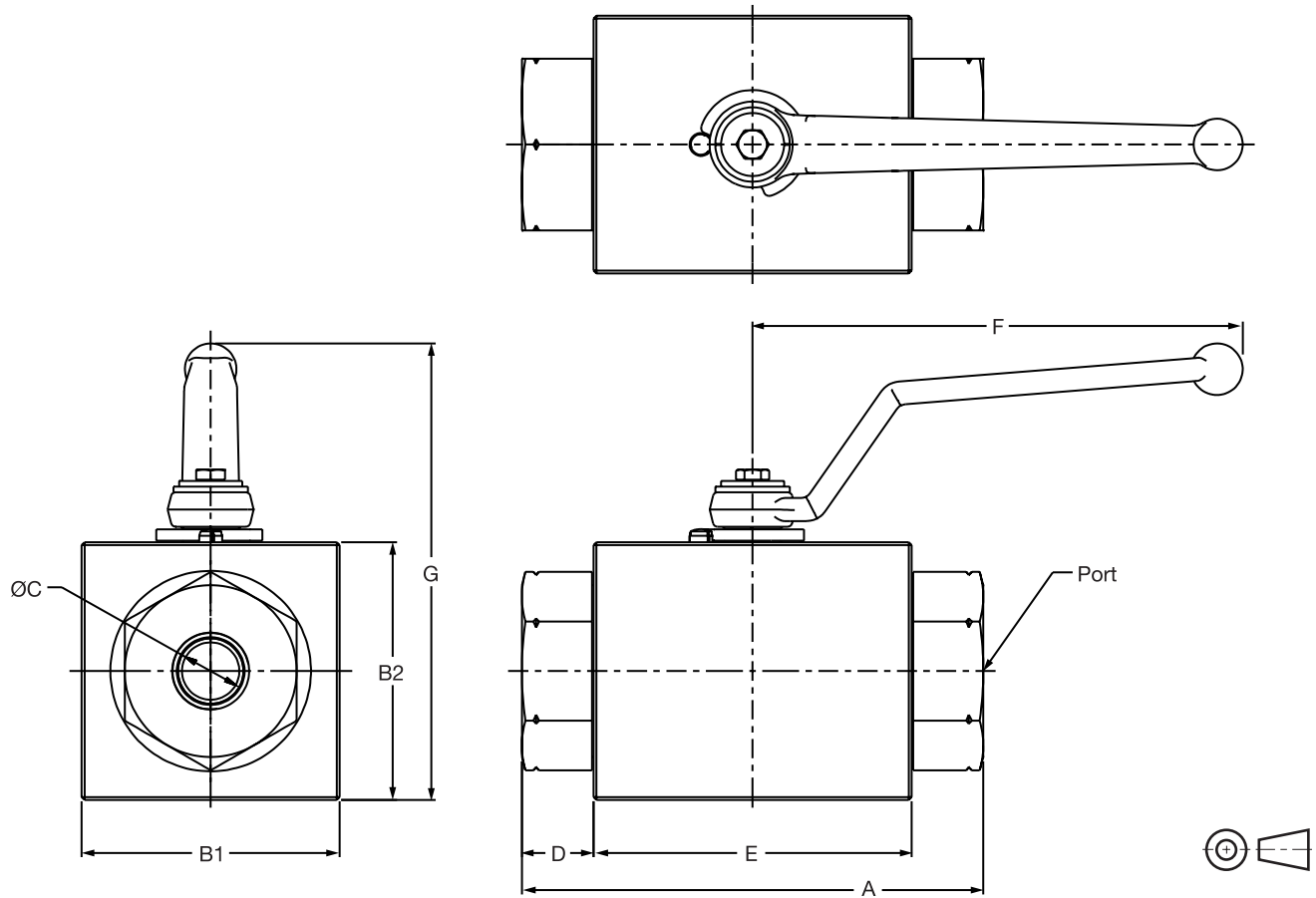

Code	Port Thread Size	Working Pressure	A	B1	B2	C	D	E	F	G
BVHH (Steel) – NPT, SAE and BSPP										
08	1/2"	800 Bar (11,600 PSI)	130 (5.12)	50 (1.97)	50 (1.97)	13 (0.51)	54 (2.13)	76 (2.99)	115 (4.53)	101 (3.98)
12	3/4"	800 Bar (11,600 PSI)	161 (6.34)	90 (3.54)	90 (3.54)	20 (0.79)	50 (1.97)	111 (4.37)	171 (6.73)	159 (6.26)
16	1"	800 Bar (11,600 PSI)	164 (6.46)	90 (3.54)	90 (3.54)	25 (0.98)	53 (2.09)	111 (4.37)	171 (6.73)	159 (6.26)
20	1 1/4"	690 Bar (10,000 PSI)	165 (6.50)	109 (4.29)	N/A	32 (1.26)	26.5 (1.04)	112 (4.41)	306 (12.0)	194 (7.61)
24	1 1/2"	690 Bar (10,000 PSI)	159 (6.26)	112 (4.41)	N/A	38 (1.50)	31.5 (1.24)	96 (3.78)	320 (12.6)	201 (7.91)
32	2"	690 Bar (10,000 PSI)	211.4 (8.32)	148 (5.83)	N/A	45 (1.77)	33.5 (1.32)	144.4 (5.69)	320 (12.6)	235.5 (9.27)

Threaded Ports (Stainless Steel)

Inch equivalents for millimeter dimensions are shown in (**)

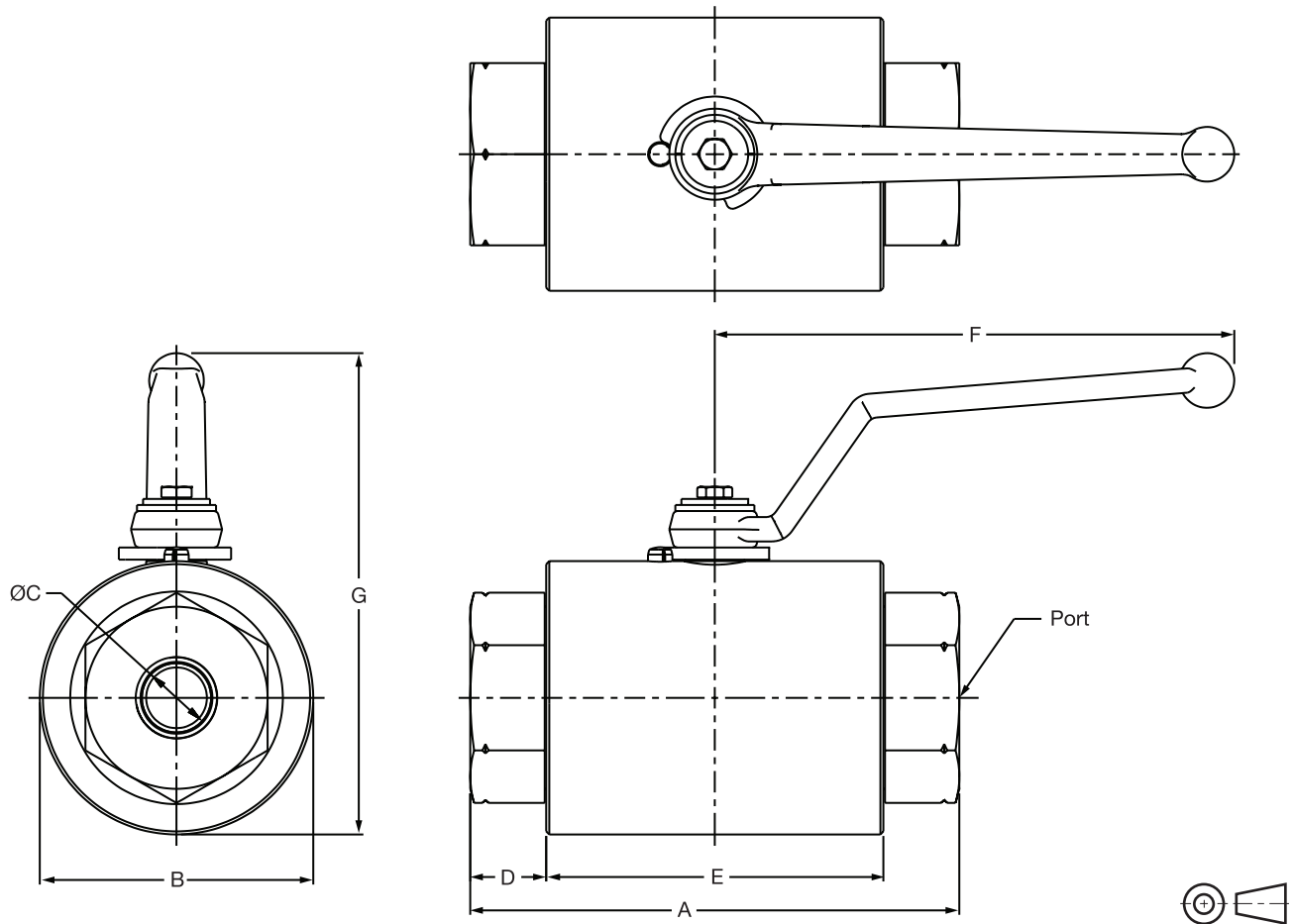

Code	Port Thread Size	Working Pressure	A	B	C	D	E	F	G
------	------------------	------------------	---	---	---	---	---	---	---

BVHH (Stainless Steel) – NPT, SAE and BSPP

08	1/2"	800 Bar (11,600 PSI)	130 (5.12)	50 (1.97)	13 (0.51)	27 (1.06)	76 (2.99)	115 (4.53)	101 (3.98)
12	3/4"	800 Bar (11,600 PSI)	161 (6.34)	90 (3.54)	20 (0.79)	25 (0.98)	111 (4.37)	171 (6.73)	159 (6.26)
16	1"	800 Bar (11,600 PSI)	164 (6.46)	90 (3.54)	25 (0.98)	26.5 (1.04)	111 (4.37)	171 (6.73)	159 (6.26)
20	1 1/4"	690 Bar (10,000 PSI)	165 (6.50)	109 (4.29)	32 (1.26)	26.5 (1.04)	112 (4.41)	306 (12.0)	194 (7.64)
24	1 1/2"	690 Bar (10,000 PSI)	159 (6.26)	112 (4.41)	38 (1.50)	31.5 (1.24)	96 (3.78)	320 (12.6)	201 (7.91)
32	2"	690 Bar (10,000 PSI)	211.4 (8.32)	148 (5.83)	45 (1.77)	33.5 (1.32)	144.4 (5.69)	320 (12.6)	235.5 (9.27)

BVHPLK: Standard Series 'BVHPLK-*-**' kit replaces the stopwasher with a stationary and moving plate, as illustrated below. As the handle is actuated, the moving plate aligns with one of the two locking positions in the stationary plate, enabling the valve to be locked in either **fully closed** or **fully open** position.

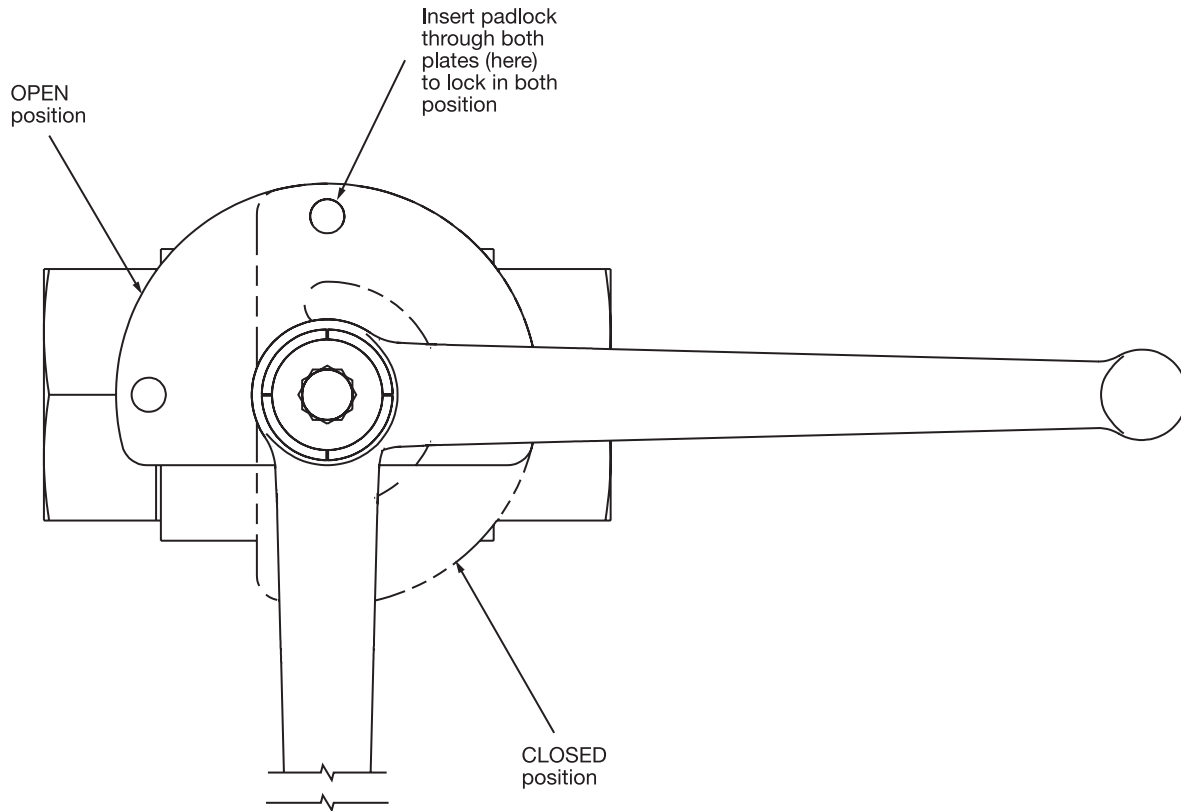

Ordering Information

BVHH Code	Size	Standard Locking (Part Number)
08	1/2"	BVHPLK-1-20
12	3/4"	BVHPLK-2-20
16	1"	BVHPLK-2-20
20	1 1/4"	BVHPLK-3-20
24	1 1/2"	BVHPLK-3-20
32	2"	BVHPLK-3-20

General Description

Series BV3D is a 3-way diverter. The product is rated at 500 Bar (7250 PSI) and designed to economically satisfy many 3-way applications.

Operation

Series BV3D operates by rotating the handle 90° or 180° depending on the chosen ball pattern. There is a slight port to port overlap. Pressure is applied to Port 1.

Specifications

Maximum Pressure	500 Bar (7250 PSI)
Body Material	Steel, ZnFe Plated 316Ti Stainless Steel
Ball Material	Steel, Chrome Plated 316 Stainless Steel
Stem Material	Steel, Zinc Plated 316 Stainless Steel
Standard Handle	Steel Offset, Zinc Plated
Standard Ball Seals	Delrin + MoS ₂
Standard Shaft Seals	Nitrile O-Ring, PTFE Backup
Temperature Range with Standard Seals	-30°C to +100°C (-22°F to +212°F)

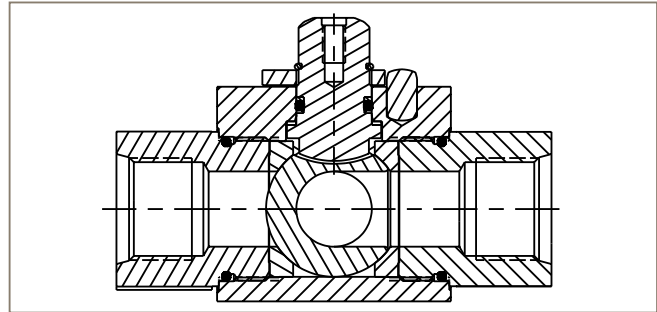
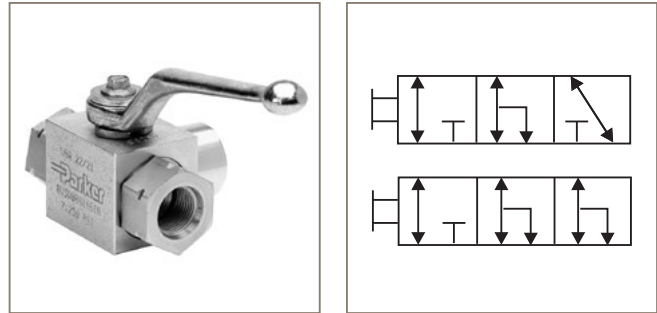

Features

- The standard L-bore ball and T-bore option allows the valve to be utilized in a variety of applications.
- Slight port overlap reduces upstream shock during shifting.
- Utilizing the unique spindle thrust bearing design reduces actuation torque.
- The BV3D can be panel mounted which allows a variety of installation options.
- Delrin seals with molybdenum disulphide (MoS₂) results in lower actuation torque and will increase high duty life cycle expectancy.

Performance Curves

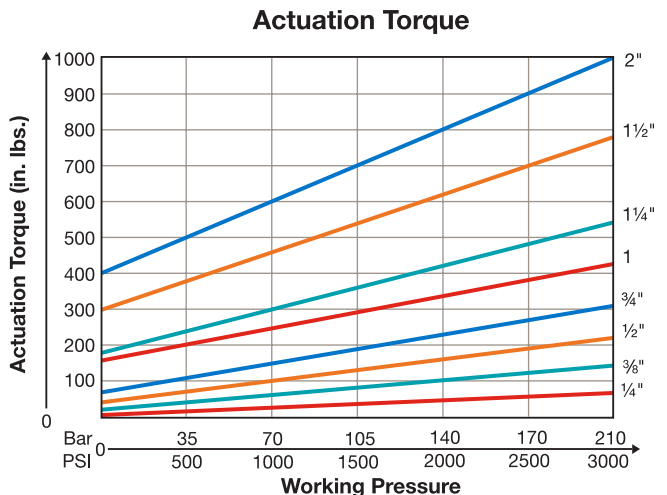
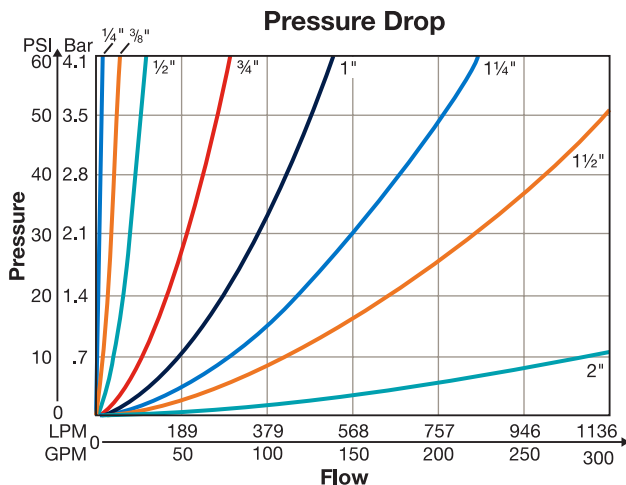

WARNING: This product can expose you to chemicals including Lead, Nickel (Metallic), or 1,3-Butadiene which are known to the State of California to cause cancer, and Lead or 1,3-Butadiene which is known to the State of California to cause birth defects and other reproductive harm. For more information go to www.P65Warnings.ca.gov.

Cat3300.indd, ddp, 09/22



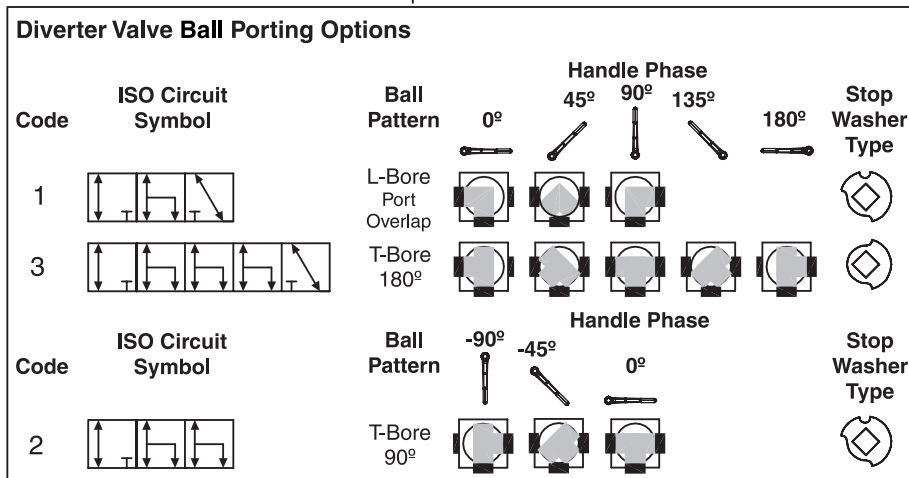
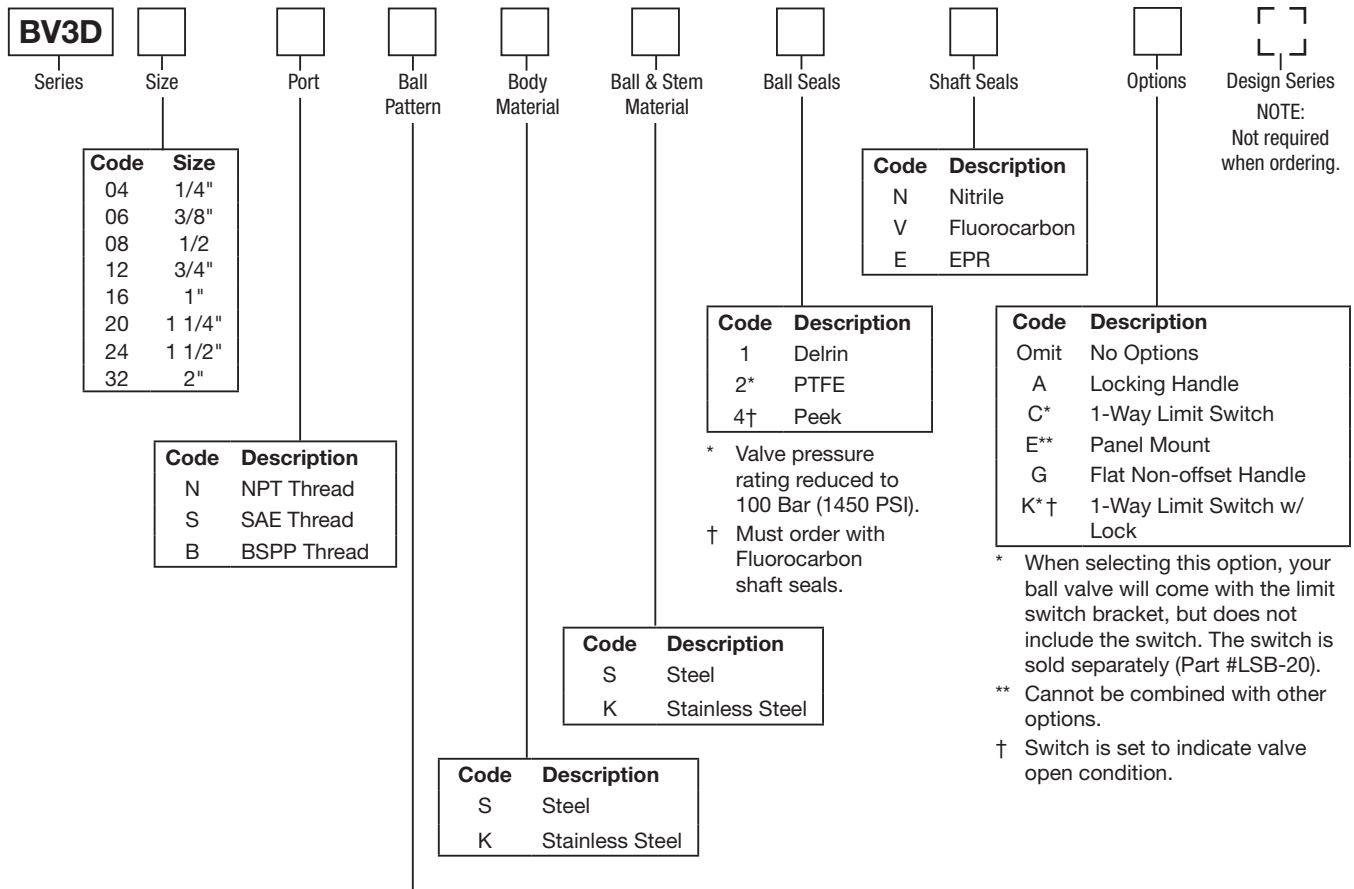

Pressure is applied to Port 1.

Weights in kg (lbs)

Size Code	Port Code						Size Code	Port Code		
	N	S	B	N	B	S				
Steel										
04	0.5 (1.10)	0.5 (1.1)	0.5 (1.01)	0.4 (0.88)	0.4 (0.88)	0.4 (0.88)	Stainless Steel			
06	0.6 (1.32)	0.6 (1.32)	0.6 (1.32)	0.6 (1.32)	0.6 (1.32)	0.6 (1.32)	0.6 (1.32)	0.6 (1.32)	0.6 (1.32)	0.6 (1.32)
08	0.7 (1.54)	0.7 (1.54)	0.7 (1.54)	0.7 (1.54)	0.7 (1.54)	0.7 (1.54)	0.7 (1.54)	0.7 (1.54)	0.7 (1.54)	0.7 (1.54)
12	1.8 (3.97)	1.8 (3.97)	1.8 (3.97)	1.8 (3.97)	1.8 (3.97)	1.8 (3.97)	1.8 (3.97)	1.8 (3.97)	1.8 (3.97)	1.8 (3.97)
16	2.4 (5.29)	2.7 (5.95)	2.4 (5.29)	2.4 (5.29)	2.4 (5.29)	2.4 (5.29)	2.4 (5.29)	2.8 (6.17)	2.8 (6.17)	2.8 (6.17)
20	5.2 (11.46)	5.2 (11.46)	4.8 (10.58)	4.8 (10.58)	4.8 (10.58)	4.8 (10.58)	5.4 (11.90)	7.0 (15.43)	7.0 (15.43)	7.0 (15.43)
24	10.0 (22.05)	10.0 (22.05)	8.9 (19.62)	8.9 (19.62)	8.9 (19.62)	8.9 (19.62)	9.4 (20.72)	10.5 (23.15)	10.5 (23.15)	10.5 (23.15)
32	12.2 (26.90)	12.2 (26.90)	12.4 (27.34)	12.4 (27.34)	12.4 (27.34)	12.4 (27.34)	13.0 (28.66)	14.5 (31.97)	14.5 (31.97)	14.5 (31.97)

Threaded Ports

Inch equivalents for millimeter dimensions are shown in (**)

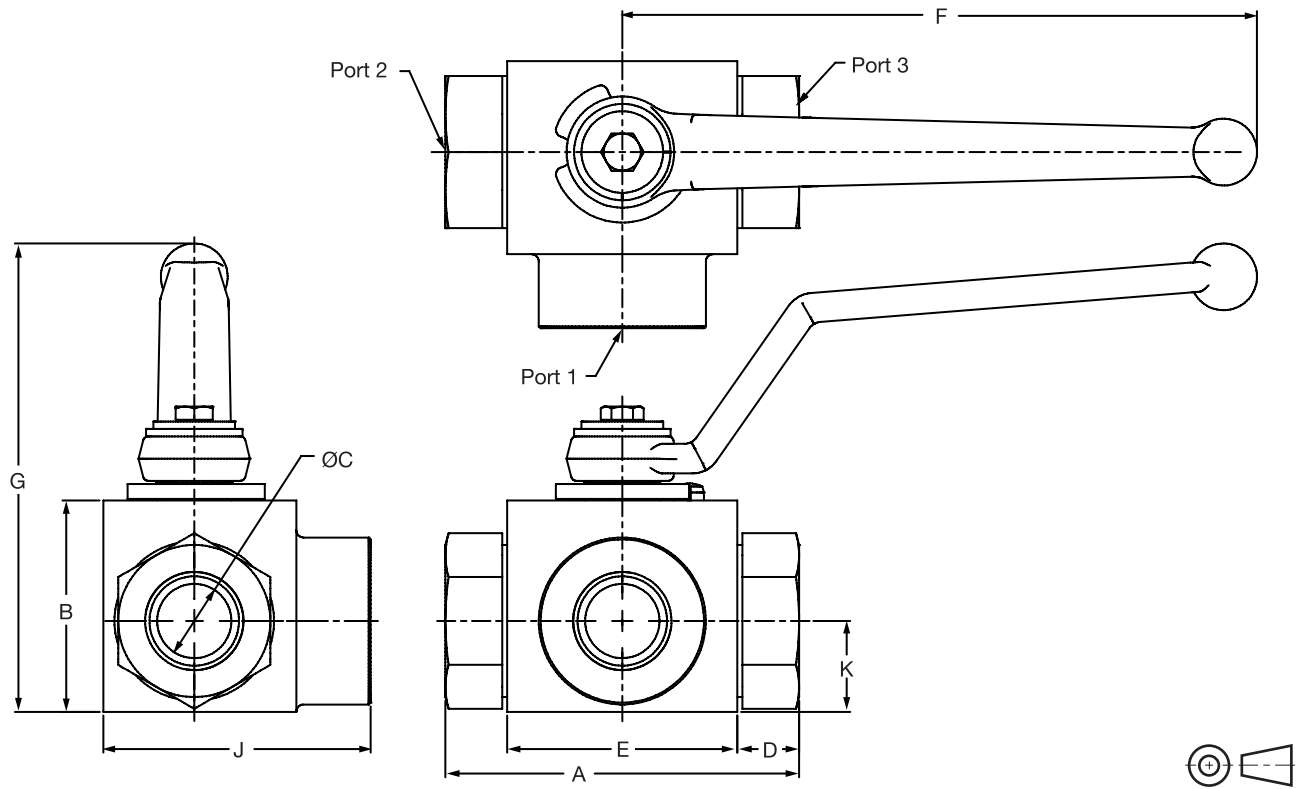

Port 1 is the pressure port.

Code	Port Thread Size	Working Pressure	A	B	C	D	E	F	G	J	K
BV3D – NPT											
04	1/4"	500 Bar (7250 PSI)	69 (2.72)	33 (1.30)	6 (0.24)	14.5 (0.57)	40 (1.57)	115 (4.53)	82 (3.23)	47.5 —	13.5 (0.53)
06	3/8"	500 Bar (7250 PSI)	72 (2.83)	38 (1.50)	10 (0.39)	14.5 (0.57)	43 (1.69)	115 (4.53)	86 (3.39)	52 —	17.5 (0.69)
08	1/2"	500 Bar (7250 PSI)	83 (3.27)	40 (1.57)	13 (0.51)	17.5 (0.69)	48 (1.89)	115 (4.53)	89 (3.50)	59* (2.32)	19 (0.75)
12	3/4"	315 Bar (4500 PSI)	95 (3.74)	57 (2.24)	20 (0.79)	16.5 (0.65)	62 (2.44)	171 (6.73)	126 (4.96)	72 (2.83)	24.5 (0.96)
16	1"	315 Bar (4500 PSI)	113 (4.45)	65 (2.56)	25 (0.98)	23.5 (0.93)	66 (2.60)	171 (6.73)	134 (5.28)	85.5 (3.37)	29.5 (1.16)
20	1 1/4"	350 Bar (5000 PSI)	120 (4.72)	84.5 (3.33)	30 (1.18)	19.5 (0.77)	81 (3.19)	306 (12.05)	177 (6.97)	99 (3.90)	39 (1.54)
24	1 1/2"	350 Bar (5000 PSI)	140 (5.51)	106 (4.17)	38 (1.50)	18 (0.71)	104 (4.09)	306 (12.05)	198 (7.80)	123 (4.84)	53 (2.09)
32	2"	350 Bar (5000 PSI)	150 (5.91)	116 (4.57)	48 (1.89)	16 (0.63)	118 (4.65)	306 (12.05)	208 (8.19)	133 (5.24)	58 (2.28)

* Dimension J for Stainless Steel is 57 mm (2.24").

Continued on the following page.

Threaded Ports (Continued)

Inch equivalents for millimeter dimensions are shown in (**)

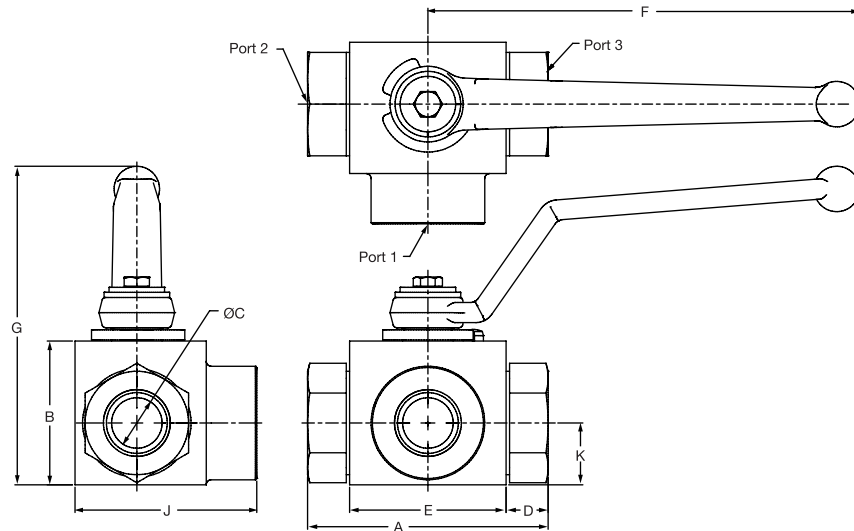

Code	Port Thread Size	Working Pressure	A	B	C	D	E	F	G	J	K
BV3D – SAE											
04	1/4"	500 Bar (7250 PSI)	69 (2.72)	33 (1.30)	5 (0.20)	14.5 (0.57)	40 (1.57)	115 (4.53)	82 (3.23)	47.5 —	13.5 (0.53)
06	3/8"	500 Bar (7250 PSI)	72 (2.83)	38 (1.50)	10 (0.39)	14.5 (0.57)	43 (1.69)	115 (4.53)	86 (3.39)	52 —	17.5 (0.69)
08	1/2"	500 Bar (7250 PSI)	83 (3.27)	40 (1.57)	13 (0.51)	17.5 (0.69)	48 (1.89)	115 (4.53)	89 (3.50)	59 (2.32)	19 (0.75)
12	3/4"	315 Bar (4500 PSI)	95 (3.74)	57 (2.24)	20 (0.79)	16.5 (0.65)	62 (2.44)	171 (6.73)	126 (4.96)	72 (2.83)	24.5 (0.96)
16	1"	315 Bar (4500 PSI)	113 (4.45)	65 (2.56)	25 (0.98)	23.5 (0.93)	66 (2.60)	171 (6.73)	134 (5.28)	85.5 (3.37)	29.5 (1.16)
20	1 1/4"	350 Bar (5000 PSI)	111 (4.37)	84.5 (3.33)	30 (1.18)	15 (0.59)	81 (3.19)	306 (12.05)	177 (6.97)	99 (3.90)	39 (1.54)
24	1 1/2"	350 Bar (5000 PSI)	140 (5.51)	106 (4.17)	38 (1.50)	18 (0.71)	104 (4.09)	306 (12.05)	198 (7.80)	123 (4.84)	53 (2.09)
32	2"	350 Bar (5000 PSI)	150 (5.91)	116 (4.57)	48 (1.89)	16 (0.63)	118 (4.65)	306 (12.05)	208 (8.19)	133 (5.24)	58 (2.28)
BV3D – BSPP											
04	1/4"	500 Bar (7250 PSI)	69 (2.72)	33 (1.30)	6 (0.24)	14.5 (0.57)	40 (1.57)	115 (4.53)	82 (3.23)	47.5 —	13.5 (0.53)
06	3/8"	500 Bar (7250 PSI)	72 (2.83)	38 (1.50)	10 (0.39)	14.5 (0.57)	43 (1.69)	115 (4.53)	86 (3.39)	52 —	17.5 (0.69)
08	1/2"	500 Bar (7250 PSI)	83 (3.27)	40 (1.57)	13 (0.51)	17.5 (0.69)	48 (1.89)	115 (4.53)	89 (3.50)	59 (2.32)	19 (0.75)
12	3/4"	315 Bar (4500 PSI)	95 (3.74)	57 (2.24)	20 (0.79)	16.5 (0.65)	62 (2.44)	171 (6.73)	126 (4.96)	72 (2.83)	24.5 (0.96)
16	1"	315 Bar (4500 PSI)	113 (4.45)	65 (2.56)	25 (0.98)	23.5 (0.93)	66 (2.60)	171 (6.73)	134 (5.28)	85.5 (3.37)	29.5 (1.16)
20	1 1/4"	350 Bar (5000 PSI)	111 (4.37)	84.5 (3.33)	30 (1.18)	15 (0.59)	81 (3.19)	306 (12.05)	177 (6.97)	94 (3.70)	39 (1.54)
24	1 1/2"	350 Bar (5000 PSI)	130 (5.12)	106 (4.17)	38 (1.50)	13 (0.51)	104 (4.09)	306 (12.05)	198 (7.80)	118 (4.65)	53 (2.09)
32	2"	350 Bar (5000 PSI)	150 (5.91)	116 (4.57)	48 (1.89)	16 (0.63)	118 (4.65)	306 (12.05)	208 (8.19)	133 (5.24)	58 (2.28)

Ball Valve Seal Kits restore a ball valve to factory specifications, providing no erosion or metal-to-metal wear has taken place.

The Seal Kit includes all the o-rings, ball seals and thrust bearings that were originally installed at the factory. A sketch of these parts is provided at the right.

Ordering Information

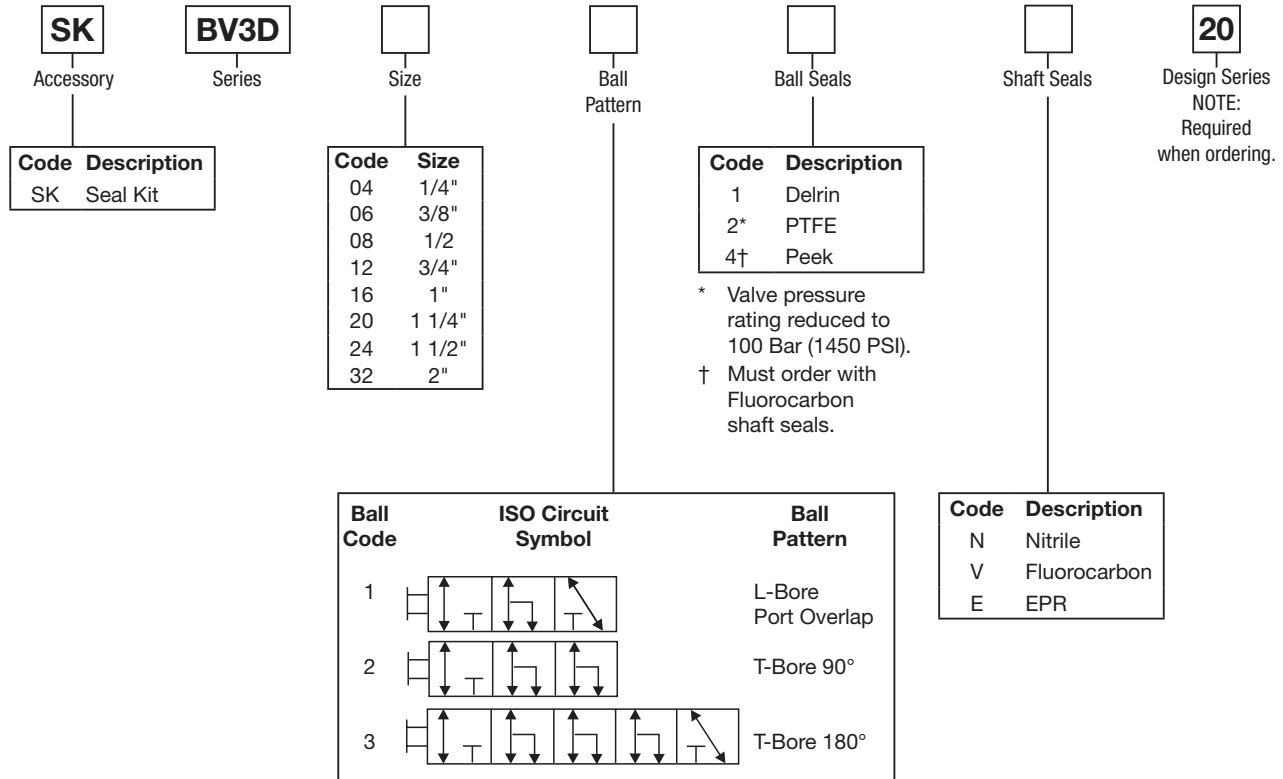

BVHPLK: Standard Series 'BVHPLK-*-*' kit replaces the stopwasher with a stationary and moving plate, as illustrated below. As the handle is actuated, the moving plate aligns with one of the two locking positions in the stationary plate, enabling the valve to be locked in either **fully closed** or **fully open** position.

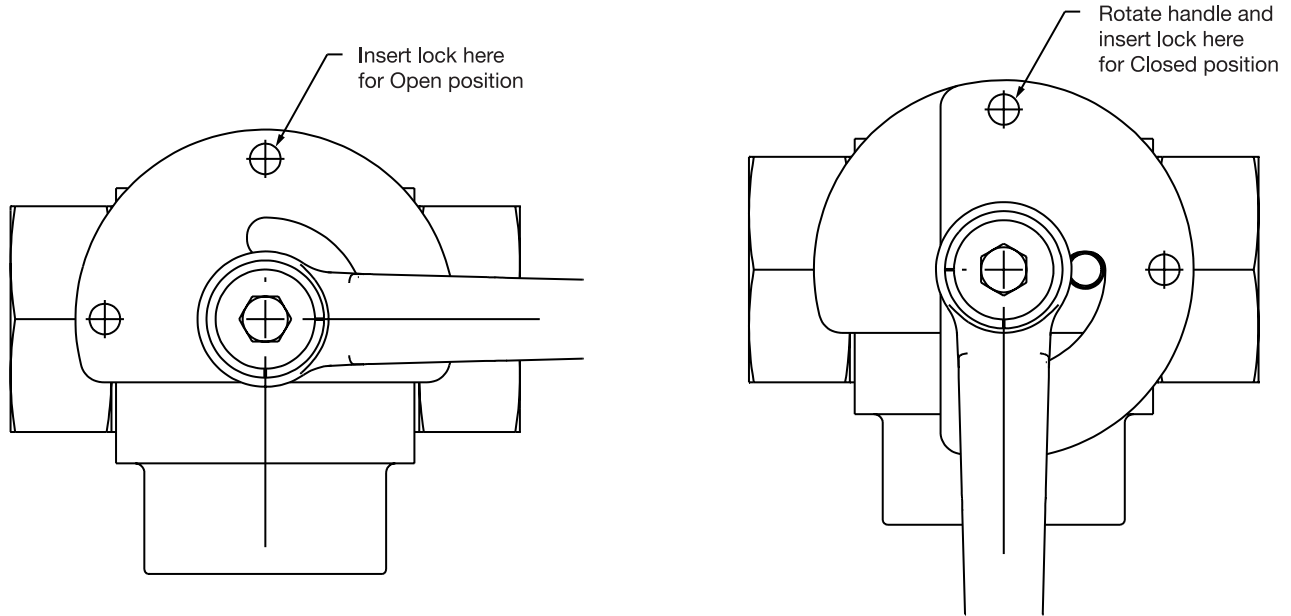

Ordering Information

BV3D		Standard Locking
Code	Size	(Part Number)
04	1/4"	BVHPLK-1-20
06	3/8"	BVHPLK-1-20
08	1/2"	BVHPLK-1-20
12	3/4"	BVHPLK-2-20
16	1"	BVHPLK-2-20
20	1 1/4"	BVHPLK-3-20
24	1 1/2"	BVHPLK-3-20
32	2"	BVHPLK-3-20

General Description

Series BV3H and BV4H are true 3-way and 4-way high pressure valves, incorporating many of the advanced features of the 2-way product. These products come in steel and are rated at 500 Bar (7250 PSI). Ports range from 1/4" to 2" with a variety of porting options.

Operation

Series BV3H operates by rotating the handle 90° and BV4H operates through 180° rotation of the handle, depending on the flow path. A BV4H with ball #4 is 90° operation.

Specifications

Maximum Pressure	500 Bar (7250 PSI)
Body Material	Steel, ZnFe Plated 316Ti Stainless Steel
Ball Material	Steel 316 Stainless Steel, Chrome Plated Trunnion mount
Standard Pattern	"L" Bore (3W), "T" Bore (4W)
Spindle Material	Steel, Zinc Plated Stainless Steel
Standard Handle	Anodized Aluminum
Standard Ball Seals	Delrin + MoS ₂
Standard Shaft Seals	O-Ring & Bushings
Temperature Range with Standard Seals	-30°C to +100°C (-22°F to +212°F)

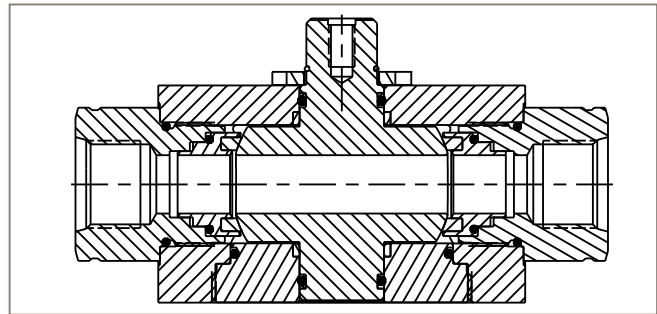
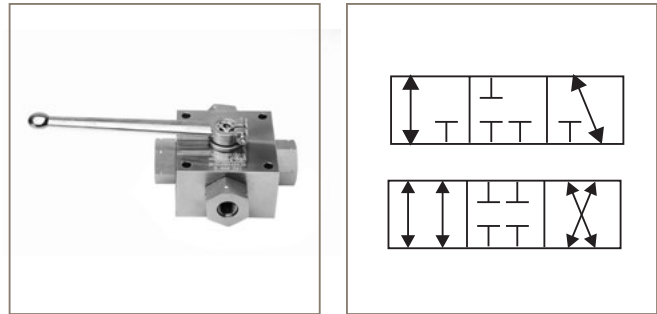

Features

- Three dimensional balanced sealing for near zero leakage in any circuit.
- The unique thrust bearing spindle design reduces actuation torque and reduces the chance of the valve seizing when inactive for periods of time.
- Special seal design enables high port to port ΔP application suitability.
- A variety of ball patterns allows flexibility in many applications.

Performance Curves

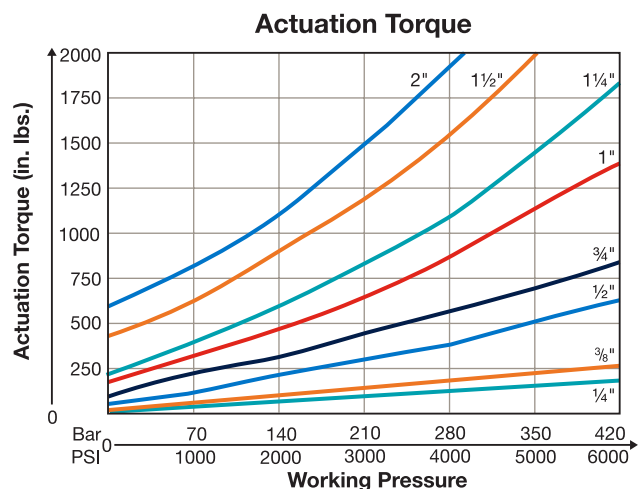
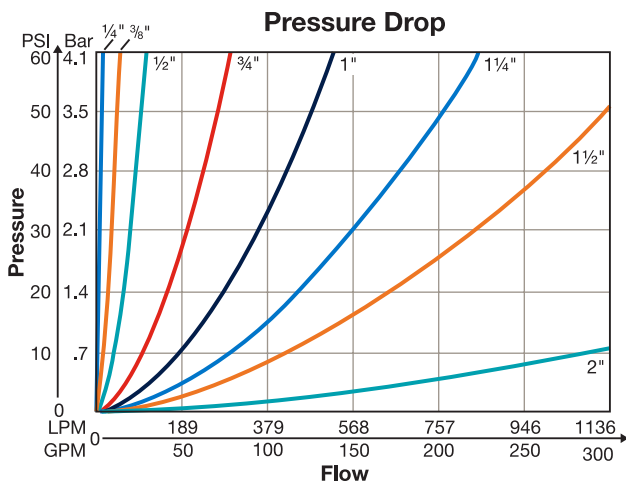

WARNING: This product can expose you to chemicals including Lead, Nickel (Metallic), or 1,3-Butadiene which are known to the State of California to cause cancer, and Lead or 1,3-Butadiene which is known to the State of California to cause birth defects and other reproductive harm. For more information go to www.P65Warnings.ca.gov.

Cat3300.indd, ddp, 09/22



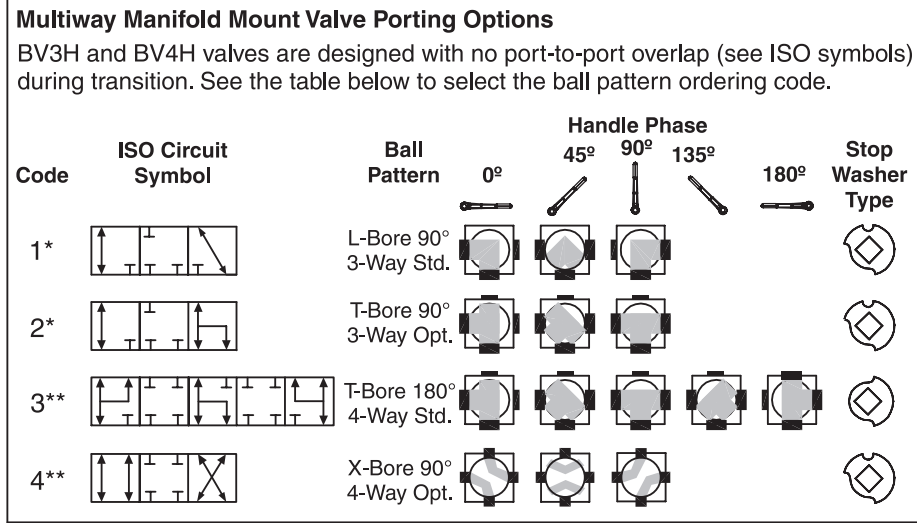
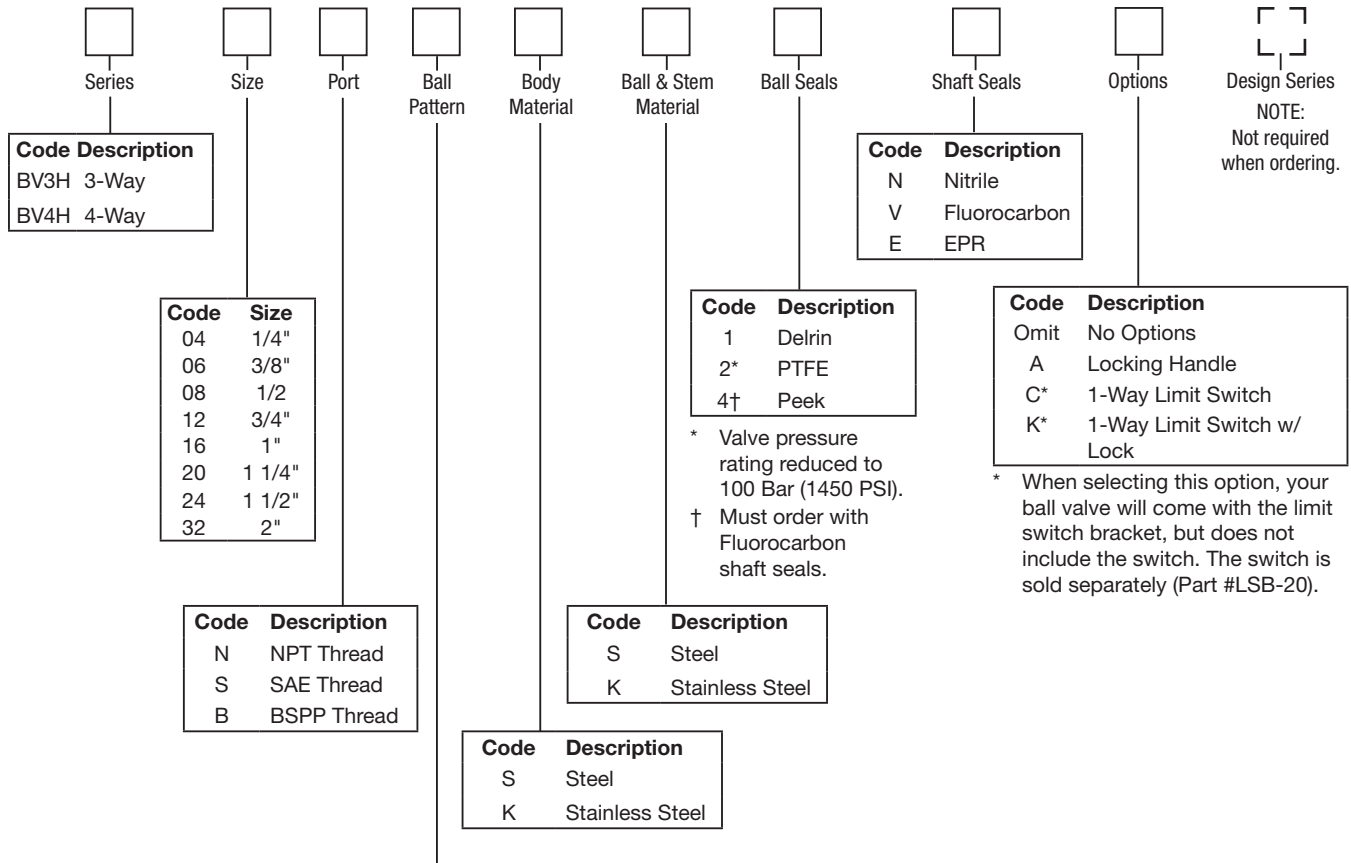

Series	Part Number
BV*H04	Flat aluminum #1 (SW12)
BV*H06	Flat aluminum #2 (SW14)
BV*H08	Flat aluminum #2 (SW14)
BV*H12	Flat aluminum #3 (SW17)
BV*H16	Flat aluminum #3 (SW17)
BV*H20	Steel crank #4 (SW19)
BV*H24	Steel crank #4 (SW19)
BV*H32	Steel crank #4 (SW19)

* BV3H only.
 ** BV4H only.

Weights in kg (lbs)

Size Code	Port Code				Size Code	Port Code	
	N, S	B				N, S, B	
BV3H							
04	1.6 (3.53)	1.6 (3.53)			04	1.6 (3.53)	
06	2.8 (6.17)	2.8 (6.17)			06	2.8 (6.17)	
08	5.2 (11.46)	4.9 (10.80)			08	4.9 (10.80)	
12	6.8 (14.99)	6.7 (14.77)			12	6.8 (14.99)	
16	8.5 (18.74)	8.3 (18.30)			16	8.5 (18.74)	
20	9.6 (21.08)	9.6 (21.08)			20	10.0 (22.07)	
24	71.8 (158.34)	71.8 (158.34)			24	74.6 (164.46)	
32	85.1 (187.66)	85.1 (187.66)			32	88.5 (195.20)	
BV4H							

Threaded Ports

Inch equivalents for millimeter dimensions are shown in (**)

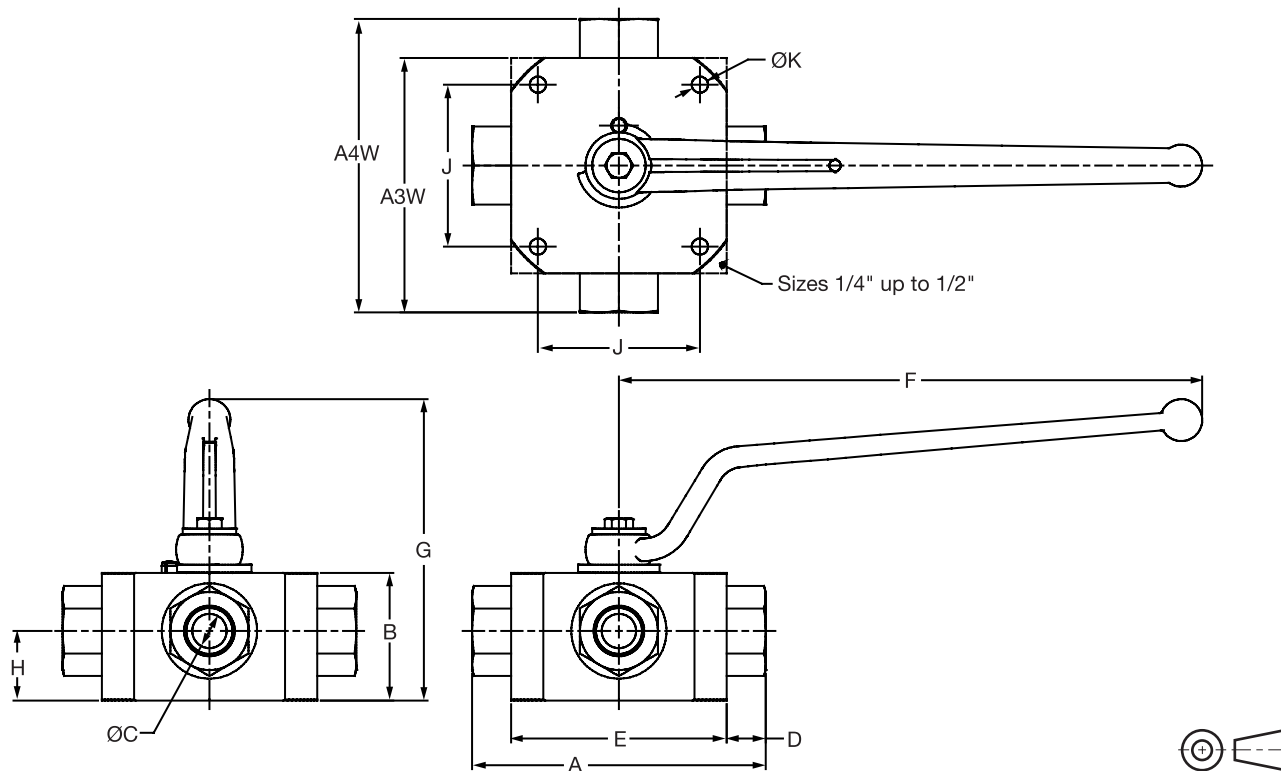

Code	Port Thread Size	Working Pressure	A3W	A4W	B	C	D	E	F	G	H	J	K
BV3H/BV4H – NPT, SAE, and BSPP													
04	1/4"	500 Bar (7250 PSI)	85 (3.35)	100 (3.94)	40 (1.57)	5 (0.20)	15 (0.59)	70 (2.76)	160 (6.30)	101 —	22 (0.87)	55 (2.17)	6.5 (0.26)
06	3/8"	500 Bar (7250 PSI)	97.5 (3.84)	115 (4.53)	50 (1.97)	8 (0.31)	17.5 (0.69)	80 (3.15)	171 (6.73)	119 —	27 (1.06)	65 (2.56)	6.5 (0.26)
08	1/2"	400 Bar (5800 PSI)	130 (5.12)	160 (6.30)	60 (2.36)	13 (0.51)	30 (1.18)	100 (3.94)	171 (6.73)	129 (5.08)	31 (1.22)	80 (3.15)	9 (0.35)
12	3/4"	315 Bar (4500 PSI)	138.5 (5.45)	164 (6.46)	67 (2.64)	18 (0.71)	25.5 (1.00)	113 (4.45)	306 (12.05)	159 (6.26)	36.5 (1.44)	85 (3.35)	8.5 (0.33)
16	1"	315 Bar (4500 PSI)	152.5 (6.00)	186 (7.32)	82 (3.23)	23 (0.91)	33.5 (1.32)	119 (4.69)	306 (12.05)	174 (6.85)	47.5 (1.87)	85 (3.35)	8.5 (0.33)
20	1 1/4"	420 Bar (6000 PSI)	218 (8.58)	242 (9.53)	150 (5.91)	32 (1.26)	24 (0.94)	194 (7.64)	600 (23.62)	226 (8.90)	84 (3.31)	130 (5.12)	13 (0.51)
24	1 1/2"	420 Bar (6000 PSI)	255 (10.04)	281 (11.06)	174 (6.85)	38 (1.50)	25.5 (1.00)	230 (9.06)	600 (23.62)	250 (9.84)	101 (3.98)	160 (6.30)	17 (0.67)
32	2"	420 Bar (6000 PSI)	276 (10.87)	297 (11.69)	180 (7.09)	48 (1.89)	21 (0.83)	255 (10.04)	900 (35.43)	254 (10.00)	101 (3.98)	175 (6.89)	17 (0.67)

Ball Valve Seal Kits restore a ball valve to factory specifications, providing no erosion or metal-to-metal wear has taken place.

The Seal Kit includes all the o-rings, ball seals and thrust bearings that were originally installed at the factory. A sketch of these parts is provided at the right.

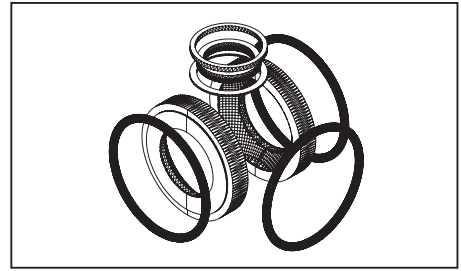

Ordering Information

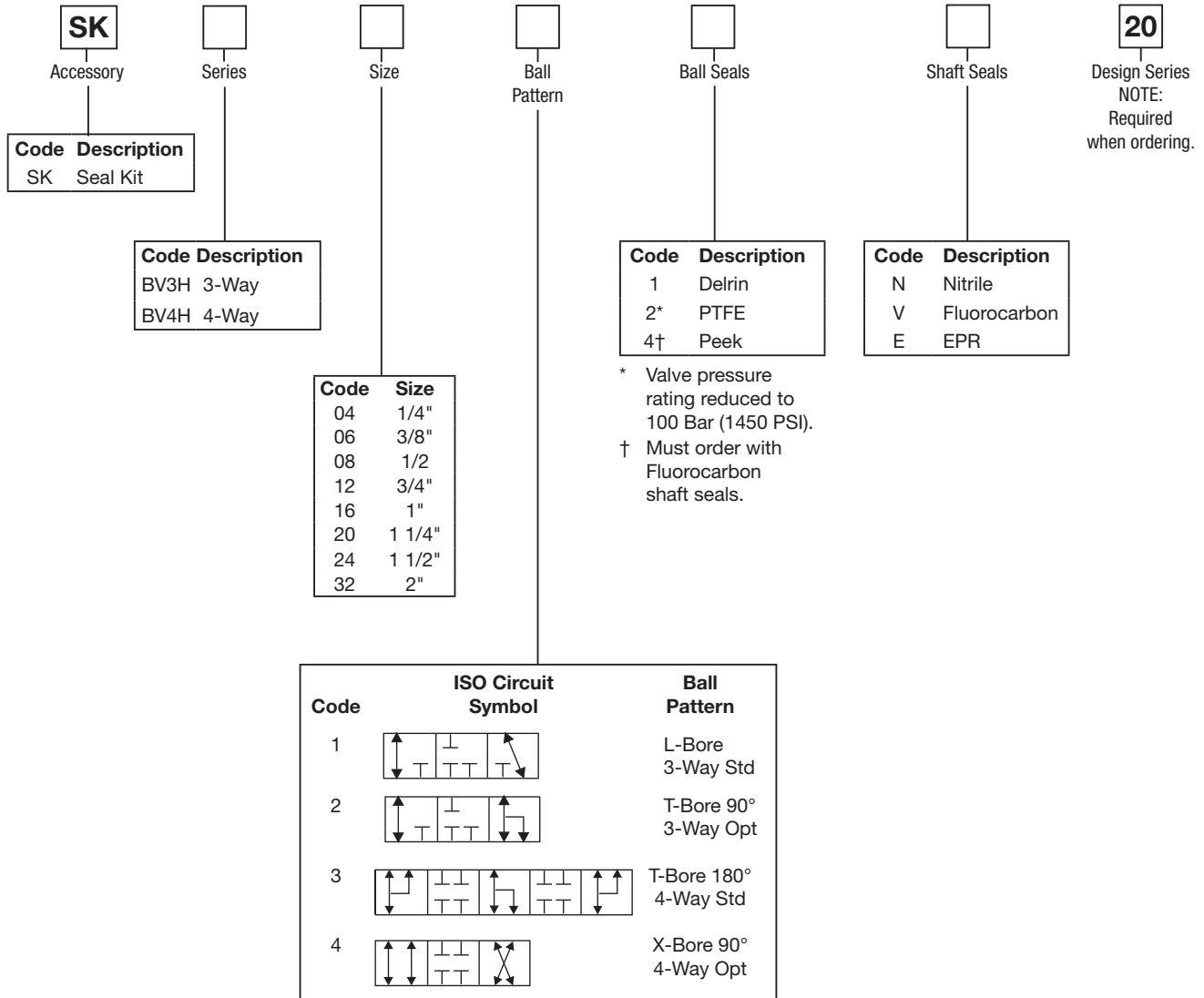

General Description

Series BVMM is a manifold mounted high pressure 500 Bar (7250 PSI) 2 or 3-way ball valve. Manifold mounting eliminates an external fluid connection.

Operation

Series BVMM valves operate through either 90° or 180° depending on the ball pattern chosen. For 3-way valves, pressure is applied to Port 1.

Specifications

Maximum Pressure	500 Bar (7250 PSI)
Body Material	Steel, ZnFe Plated 316Ti Stainless Steel
Ball Material	Steel, Chrome Plated 316 Stainless Steel, Chrome Plated
Spindle Material	Steel, Zinc Plated Stainless Steel
Standard Handle	Steel Offset, Zinc Plated
Standard Ball Seals	Delrin + MoS ₂
Standard Shaft Seals	Nitrile O-Ring & PTFE Backup Seals
Temperature Range with Standard Seals	-30°C to +100°C (-22°F to +212°F)

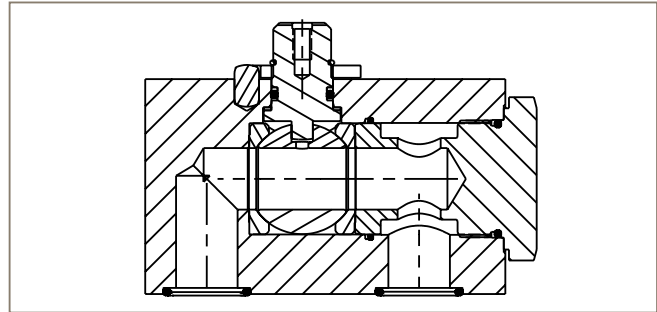
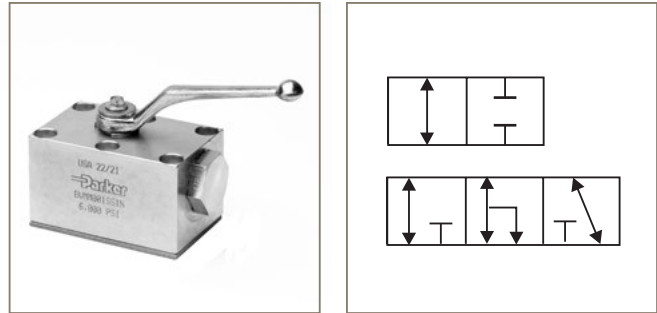

Features

- Variety of ball patterns allow for different flow paths and flexibility for many applications.
- Thrust bearings in the spindle and delrin moly ball seals result in low actuation torque as well as extended service life.

Performance Curves

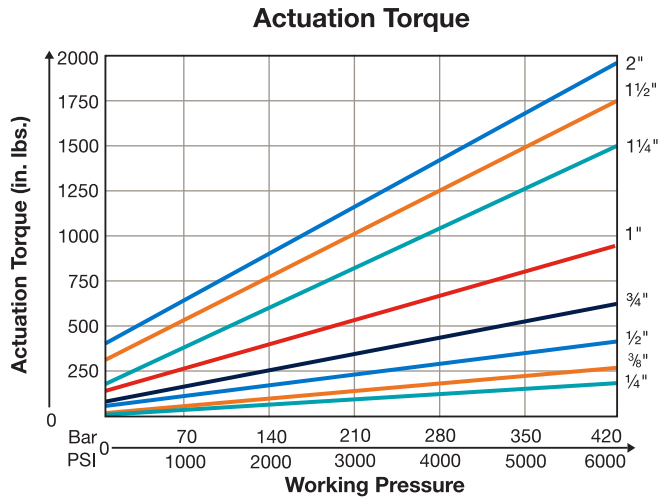
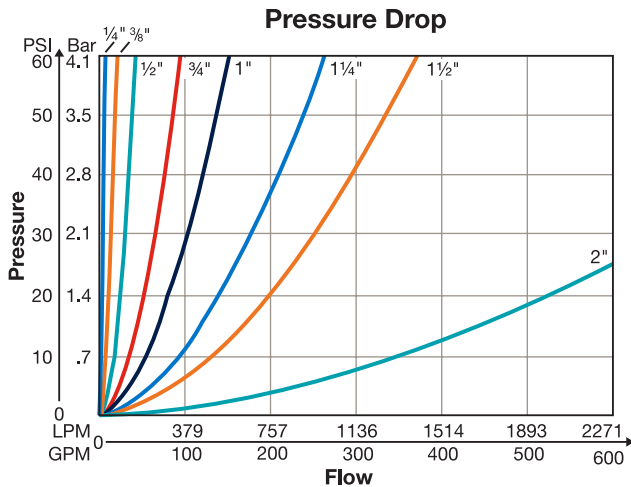

WARNING: This product can expose you to chemicals including Lead, Nickel (Metallic), or 1,3-Butadiene which are known to the State of California to cause cancer, and Lead or 1,3-Butadiene which is known to the State of California to cause birth defects and other reproductive harm. For more information go to www.P65Warnings.ca.gov.

Cat3300.indd, ddp, 09/22



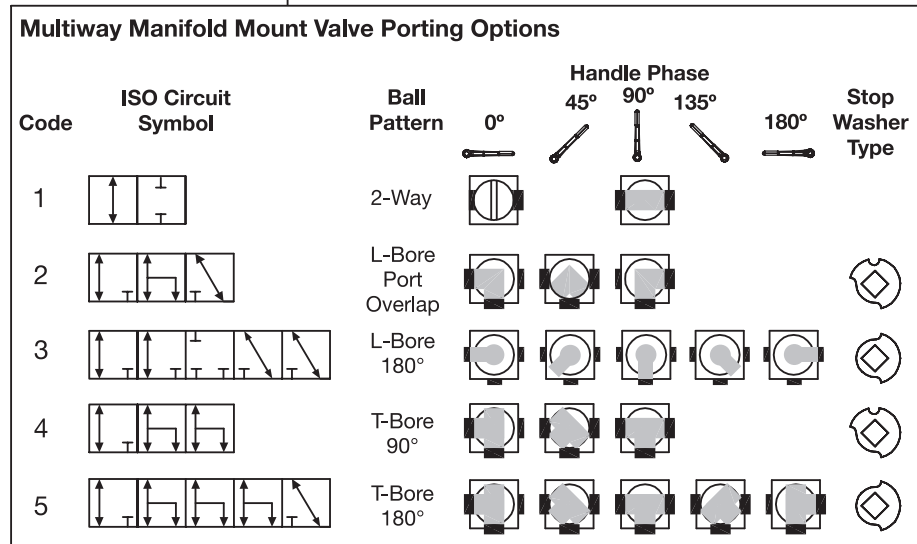
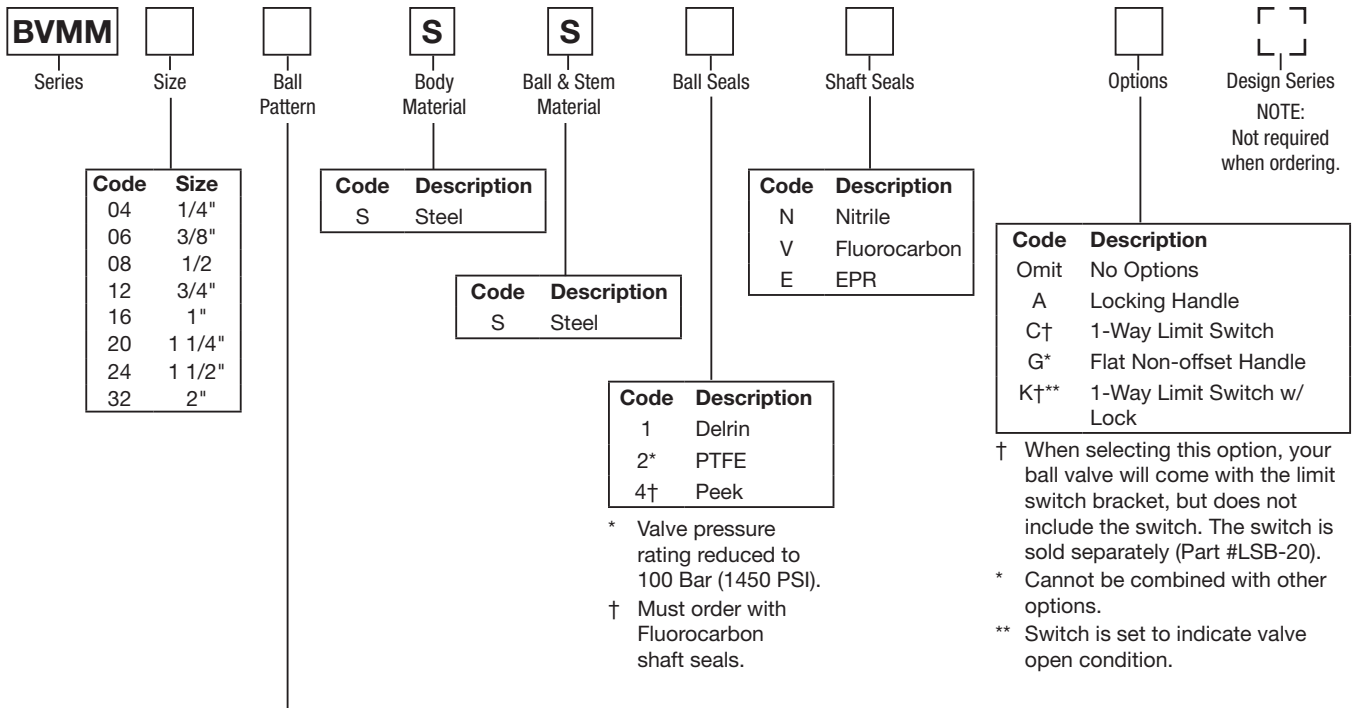

Replacement Handles Standard Steel Offset

Series	Part Number
BVMM04	BVH-HS0-20
BVMM06	BVH-HS1-20
BVMM08	BVH-HS1-20
BVMM12	BVH-HS2-20
BVMM16	BVH-HS2-20
BVMM20	BVH-HS3-20
BVMM24	BVH-HS3-20
BVMM32	BVH-HS3-20

Please request a certified print before building a manifold.

For 3-way valves, pressure is applied to Port 1.

Weights in kg (lbs)

Size Code	2-way		3-way	
Steel and Stainless Steel				
04	0.6	(1.32)	0.6	(1.32)
06	1.3	(2.87)	1.3	(2.87)
08	2.3	(5.07)	2.3	(5.07)
12	3.9	(8.64)	3.92	(8.64)
16	5.7	(12.52)	5.7	(12.52)
20	11.0	(24.25)	11.0	(24.25)
24	18.8	(41.40)	18.7	(41.23)
32*	29.7	(65.48)	28.8	(65.48)

* Weight for Stainless Steel 2-Way valve, size 32 is 29.6 (65.26).

Manifold Mounted

Inch equivalents for millimeter dimensions are shown in (**)

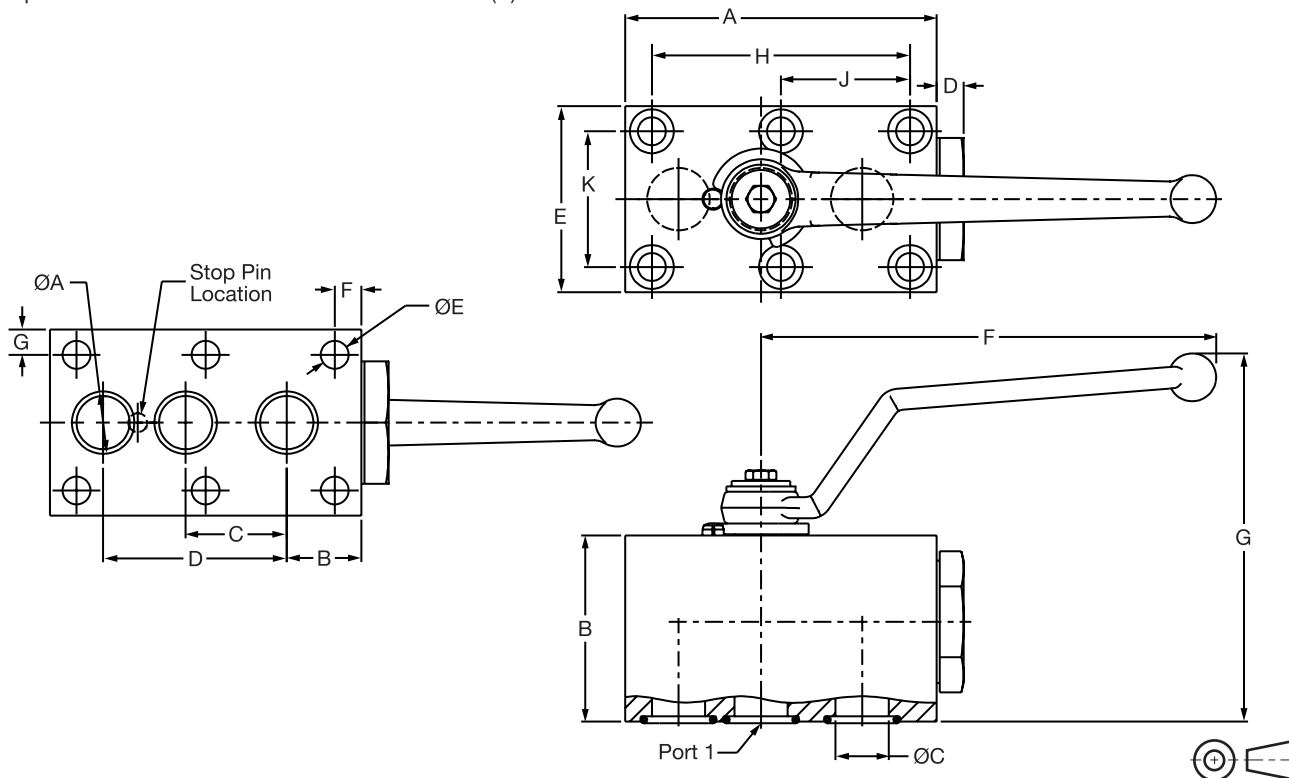

For 3-way valves, pressure is applied to Port 1.
Please request a certified print before building a manifold.

Code	Port Thread Size	Working Pressure	A	B	C**	D	E	F	G	H	J	K
BVMM – 2-Way and 3-Way Manifold Mounted												
04	1/4"	500 Bar (7250 PSI)	57 (2.24)	35 (1.38)	6 (0.24)	6 (0.24)	40 (1.57)	80 (3.15)	68 (2.68)	35 (1.38)	N/A*	27 (1.06)
06	3/8"	500 Bar (7250 PSI)	70 (2.76)	45 (1.77)	9.5 (0.37)	10 (0.39)	55 (2.17)	115 (4.53)	94 (3.70)	55 (2.17)	N/A*	40 (1.57)
08	1/2"	420 Bar (6000 PSI)	98 (3.86)	55 (2.17)	13 (0.51)	10 (0.39)	60 (2.36)	115 (4.53)	104 (4.09)	83 (3.27)	41.5 (1.63)	45 (1.77)
12	3/4"	420 Bar (6000 PSI)	117 (4.61)	70 (2.76)	20 (0.79)	10 (0.39)	70 (2.76)	171 (6.73)	140 (5.51)	97 (3.82)	48.5 (1.91)	51 (2.01)
16	1"	420 Bar (6000 PSI)	135 (5.31)	80 (3.15)	25 (0.98)	10 (0.39)	80 (3.15)	171 (6.73)	149 (5.87)	115 (4.53)	57.5 (2.26)	60 (2.36)
20	1 1/4"	420 Bar (6000 PSI)	165 (6.50)	100 (3.94)	32 (1.26)	11 (0.43)	100 (3.94)	306 (12.05)	192 (7.56)	136 (5.35)	68 (2.68)	78 (3.07)
24	1 1/2"	420 Bar (6000 PSI)	200 (7.87)	110 (4.33)	38 (1.50)	17 (0.67)	130 (5.12)	306 (12.05)	202 (7.95)	112 (4.41)	56 (2.20)	95 (3.74)
32	2"	420 Bar (6000 PSI)	240 (9.45)	129 (5.08)	48 (1.89)	15 (0.59)	150 (5.91)	306 (12.05)	221 (8.70)	136 (5.35)	68 (2.68)	112 (4.41)

* These sizes use only the four outside mounting holes. Dimension J is not applicable.

** Ball portings for multiway valves are smaller than their 2-way counterparts in some sizes. Please refer to dimension C to confirm suitability.

Manifold Porting Specifications

Inch equivalents for millimeter dimensions are shown in (**)

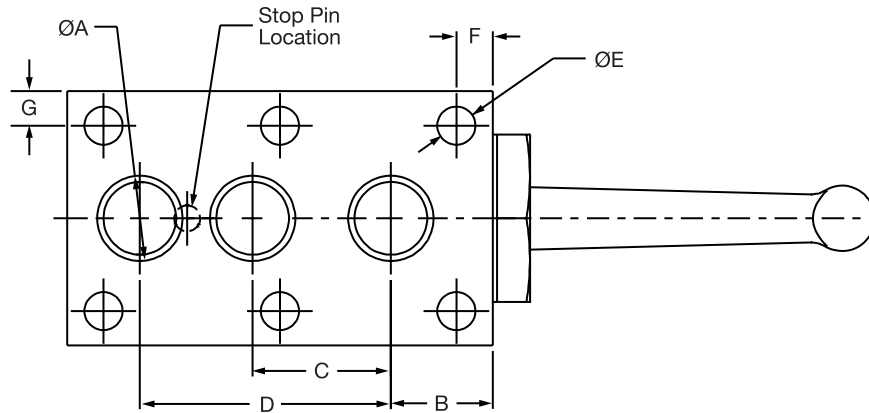

**For 3-way valves, pressure is applied to Port 1.
Please request a certified print before building a manifold.**

Code	Port Size	A	B	C*	D	E	F	G
BVMM – Mounting Pad Specifications								
04	1/4"	11.8 (0.46)	13.5 (0.53)	17.5 (0.69)	35 (1.38)	6.5 (0.26)	13.5 (0.53)	6.5 (0.26)
06	3/8"	14.9 (0.59)	16 (0.63)	25 (0.98)	44 (1.73)	8.4 (0.33)	7.5 (0.30)	7.5 (0.30)
08	1/2"	24.9 (0.98)	24 (0.94)	31.5 (1.24)	58 (2.28)	8.4 (0.33)	7.5 (0.30)	7.5 (0.30)
12	3/4"	29 (1.14)	28 (1.10)	38 (1.50)	69 (2.72)	10.5 (0.41)	10 (0.39)	9.5 (0.37)
16	1"	34.9 (1.37)	30 (1.18)	43 (1.69)	81 (3.19)	10.5 (0.41)	10 (0.39)	10 (0.39)
20	1 1/4"	40 (1.57)	40 (1.57)	50 (1.97)	96 (3.78)	13 (0.51)	17 (0.67)	11 (0.43)
24	1 1/2"	47.7 (1.88)	59.5 (2.34)	56 (2.20)	112 (4.41)	16.5 (0.65)	59.5 (2.34)	17.5 (0.69)
32	2"	59.8 (2.35)	66 (2.60)	68 (2.68)	136 (5.35)	21 (0.83)	66 (2.60)	19 (0.75)

* 2-way valves do not have a C dimension.

Ball Valve Seal Kits restore a ball valve to factory specifications, providing no erosion or metal-to-metal wear has taken place.

The Seal Kit includes all the o-rings, ball seals and thrust bearings that were originally installed at the factory. A sketch of these parts is provided at the right.

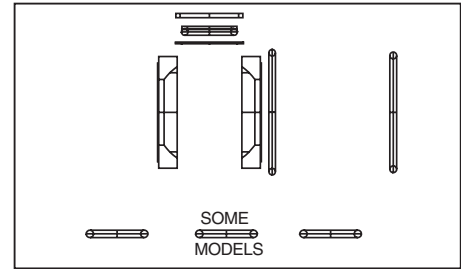

Ordering Information

<div style="border: 1px solid black; padding: 2px; width: 40px; margin: 0 auto;">SK</div> <p style="text-align: center; font-size: small;">Accessory</p> <div style="border: 1px solid black; padding: 2px; width: 100%; margin-top: 10px;"> <table border="0" style="width: 100%; border-collapse: collapse;"> <tr> <th style="text-align: left; border-right: 1px solid black; padding: 2px;">Code</th> <th style="padding: 2px;">Description</th> </tr> <tr> <td style="border-right: 1px solid black; padding: 2px;">SK</td> <td style="padding: 2px;">Seal Kit</td> </tr> </table> </div>	Code	Description	SK	Seal Kit	<div style="border: 1px solid black; padding: 2px; width: 60px; margin: 0 auto;">BVMM</div> <p style="text-align: center; font-size: small;">Series</p>	<div style="border: 1px solid black; width: 30px; height: 20px; margin: 0 auto;"></div> <p style="text-align: center; font-size: small;">Size</p> <div style="border: 1px solid black; padding: 2px; width: 100%; margin-top: 10px;"> <table border="0" style="width: 100%; border-collapse: collapse;"> <tr> <th style="text-align: left; border-right: 1px solid black; padding: 2px;">Code</th> <th style="padding: 2px;">Size</th> </tr> <tr> <td style="border-right: 1px solid black; padding: 2px;">04</td> <td style="padding: 2px;">1/4"</td> </tr> <tr> <td style="border-right: 1px solid black; padding: 2px;">06</td> <td style="padding: 2px;">3/8"</td> </tr> <tr> <td style="border-right: 1px solid black; padding: 2px;">08</td> <td style="padding: 2px;">1/2"</td> </tr> <tr> <td style="border-right: 1px solid black; padding: 2px;">12</td> <td style="padding: 2px;">3/4"</td> </tr> <tr> <td style="border-right: 1px solid black; padding: 2px;">16</td> <td style="padding: 2px;">1"</td> </tr> <tr> <td style="border-right: 1px solid black; padding: 2px;">20</td> <td style="padding: 2px;">1 1/4"</td> </tr> <tr> <td style="border-right: 1px solid black; padding: 2px;">24</td> <td style="padding: 2px;">1 1/2"</td> </tr> <tr> <td style="border-right: 1px solid black; padding: 2px;">32</td> <td style="padding: 2px;">2"</td> </tr> </table> </div>	Code	Size	04	1/4"	06	3/8"	08	1/2"	12	3/4"	16	1"	20	1 1/4"	24	1 1/2"	32	2"	<div style="border: 1px solid black; width: 30px; height: 20px; margin: 0 auto;"></div> <p style="text-align: center; font-size: small;">Ball Pattern</p>	<div style="border: 1px solid black; width: 30px; height: 20px; margin: 0 auto;"></div> <p style="text-align: center; font-size: small;">Ball Seals</p> <div style="border: 1px solid black; padding: 2px; width: 100%; margin-top: 10px;"> <table border="0" style="width: 100%; border-collapse: collapse;"> <tr> <th style="text-align: left; border-right: 1px solid black; padding: 2px;">Code</th> <th style="padding: 2px;">Description</th> </tr> <tr> <td style="border-right: 1px solid black; padding: 2px;">1</td> <td style="padding: 2px;">Delrin</td> </tr> <tr> <td style="border-right: 1px solid black; padding: 2px;">2*</td> <td style="padding: 2px;">PTFE</td> </tr> <tr> <td style="border-right: 1px solid black; padding: 2px;">4†</td> <td style="padding: 2px;">Peek</td> </tr> </table> <p style="font-size: x-small; margin-top: 5px;">* Valve pressure rating reduced to 100 Bar (1450 PSI). † Must order with Fluorocarbon shaft seals.</p> </div>	Code	Description	1	Delrin	2*	PTFE	4†	Peek	<div style="border: 1px solid black; width: 30px; height: 20px; margin: 0 auto;"></div> <p style="text-align: center; font-size: small;">Shaft Seals</p> <div style="border: 1px solid black; padding: 2px; width: 100%; margin-top: 10px;"> <table border="0" style="width: 100%; border-collapse: collapse;"> <tr> <th style="text-align: left; border-right: 1px solid black; padding: 2px;">Code</th> <th style="padding: 2px;">Description</th> </tr> <tr> <td style="border-right: 1px solid black; padding: 2px;">N</td> <td style="padding: 2px;">Nitrile</td> </tr> <tr> <td style="border-right: 1px solid black; padding: 2px;">V</td> <td style="padding: 2px;">Fluorocarbon</td> </tr> <tr> <td style="border-right: 1px solid black; padding: 2px;">E</td> <td style="padding: 2px;">EPR</td> </tr> </table> </div>	Code	Description	N	Nitrile	V	Fluorocarbon	E	EPR	<div style="border: 1px solid black; padding: 2px; width: 40px; margin: 0 auto;">20</div> <p style="text-align: center; font-size: x-small;">Design Series NOTE: Required when ordering.</p>
Code	Description																																											
SK	Seal Kit																																											
Code	Size																																											
04	1/4"																																											
06	3/8"																																											
08	1/2"																																											
12	3/4"																																											
16	1"																																											
20	1 1/4"																																											
24	1 1/2"																																											
32	2"																																											
Code	Description																																											
1	Delrin																																											
2*	PTFE																																											
4†	Peek																																											
Code	Description																																											
N	Nitrile																																											
V	Fluorocarbon																																											
E	EPR																																											

Code	ISO Circuit Symbol	Ball Pattern
1		2-Way
2		L-Bore Port Overlap
3		L-Bore 180°
4		T-Bore 90°
5		T-Bore 180°

BVMM2LK: Standard Series 'BVMM2LK-*' kit replaces the stopwasher with a stationary and moving plate, as illustrated below. As the handle is actuated, the moving plate aligns with one of the two locking positions in the stationary plate, enabling the valve to be locked in either **fully closed** or **fully open** position.

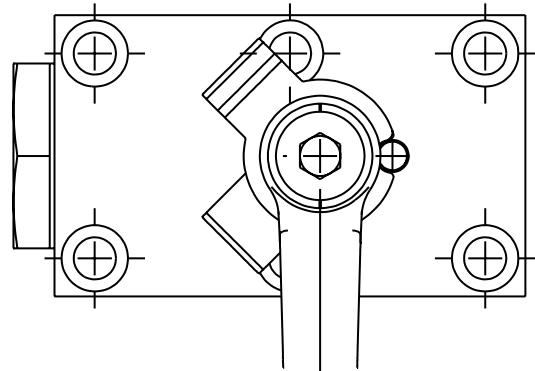
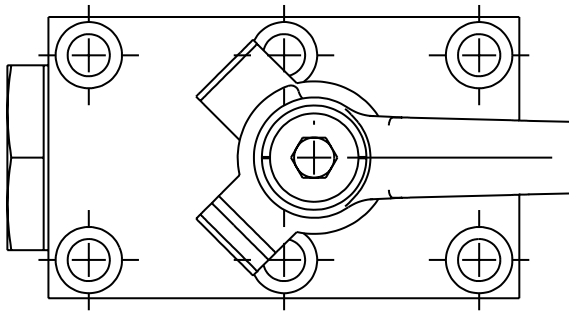

Ordering Information

BVMM		Standard Locking
Code	Size	(Part Number)
04	1/4"	BVDMLH-0-20
06	3/8"	BVDMLH-1-20
08	1/2"	BVDMLH-1-20
12	3/4"	BVDMLH-2-20
16	1"	BVDMLH-2-20
20	1 1/4"	BVDMLH-3-20
24	1 1/2"	BVDMLH-3-20
32	2"	BVDMLH-3-20

General Description

Series BVSL ball valves are designed to meet the needs of suction line and low pressure applications. This series is available from 1/4" to 4" ports NPT, SAE and BSPP, and is designed to assure leak free hydraulic suction and return line durability.

Operation

Parker's 2-way ball valves operate to either off or full flow by rotating the handle 90°. Ball valves are not designed to be a metering or flow control device.

Specifications

Maximum Pressure	100 Bar (1450 PSI)
Body Material	Aluminum
Ball Material	Steel, Chrome Plated 316 Stainless Steel
Stem Material	Steel, Zinc Plated 316 Stainless Steel
Standard Handle	Aluminum Offset, Anodized
Standard Ball Seals	PTFE
Standard Shaft Seals	Nitrile O-Ring & PTFE Backup
Temperature Range with Standard Seals	-30°C to +100°C (-22°F to +212°F)

Features

- Unrestricted bore from 1/4" to 4".
- Unrestricted flow and cavitation eliminated.
- Availability of NPT, BSPP and SAE O-ring sealed ports assure leak-free service.
- Choice of optional seal materials allows use with phosphate esters, water glycols and other media.
- Utilizes top grade PTFE ball seats with O-ring seals throughout to assure smooth and leak-free operation.

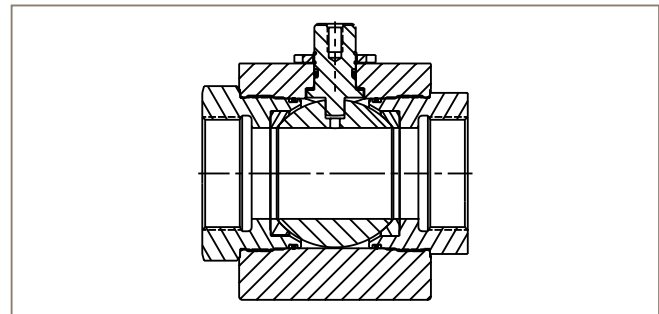
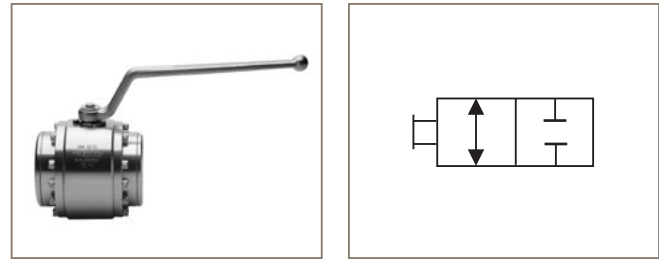

Performance Curves

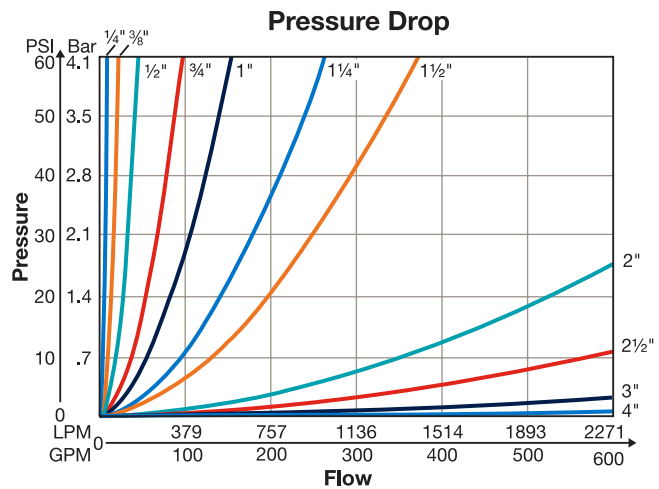

Actuation Torque

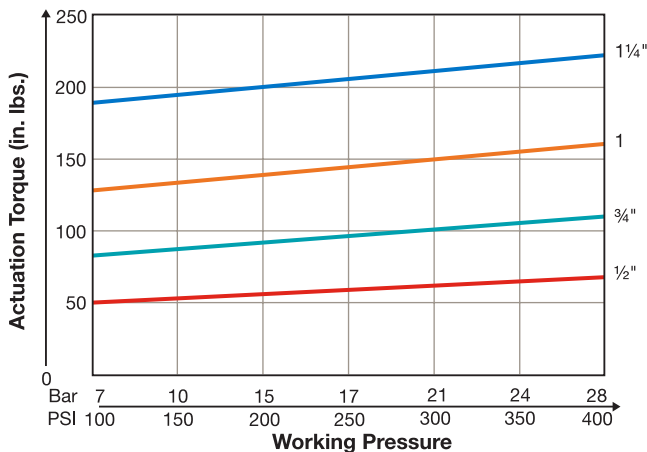

Actuation Torque

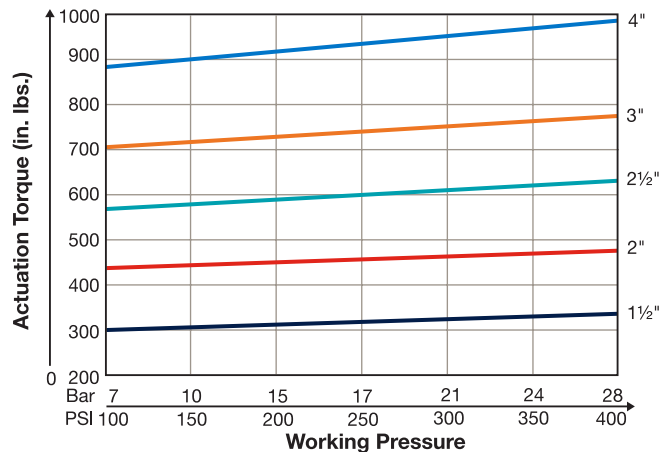

WARNING: This product can expose you to chemicals including Lead, Nickel (Metallic), or 1,3-Butadiene which are known to the State of California to cause cancer, and Lead or 1,3-Butadiene which is known to the State of California to cause birth defects and other reproductive harm. For more information go to www.P65Warnings.ca.gov.

Cat3300.indd, ddp, 09/22



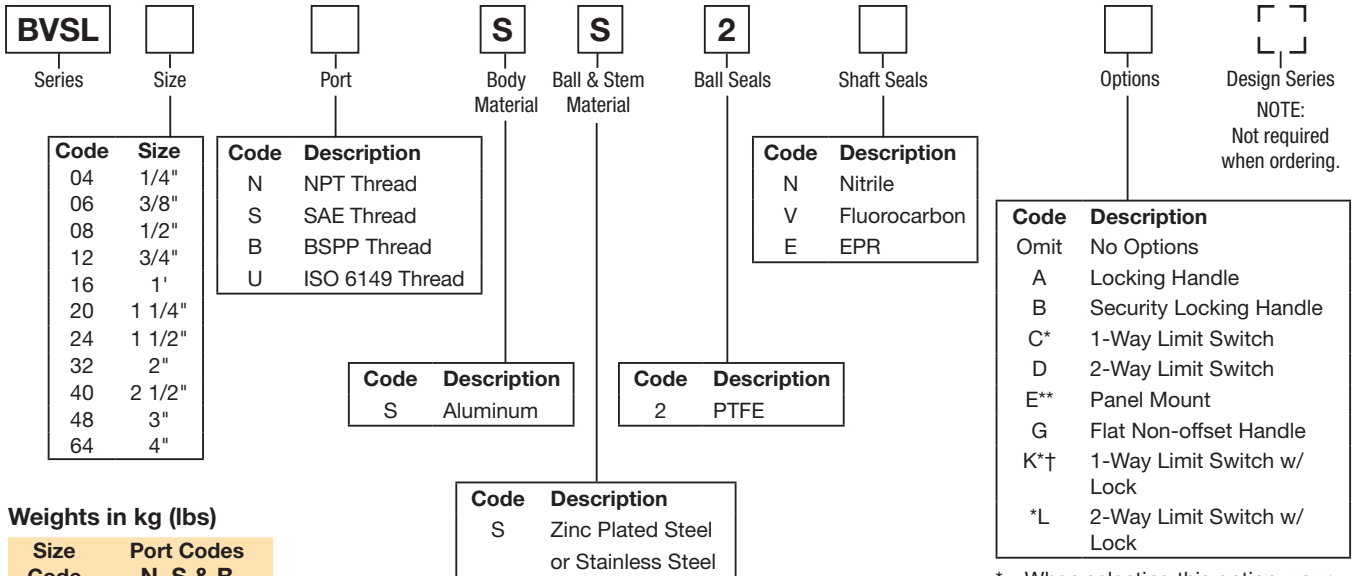

Weights in kg (lbs)

Size Code	Port Codes N, S & B
-----------	---------------------

Steel and Stainless Steel

Size Code	Weight (kg)	Weight (lbs)
04	0.27	(0.60)
06	0.32	(0.70)
08	0.36	(0.80)
12	0.68	(1.50)
16	1.14	(2.51)
20	2.73	(6.01)
24	3.64	(8.02)
32	4.55	(10.02)
40	5.45	(12.03)
48	8.64	(19.04)
64	15.91	(35.07)

- * When selecting this option, your ball valve will come with the limit switch bracket, but does not include the switch. The switch is sold separately (Part #LSB-20).
- ** Cannot be combined with other options.
- † Switch is set to indicate valve open condition.

Seal Kit Accessories

Ball Valve Seal Kits restore a ball valve to factory specifications, providing no erosion or metal-to-metal wear has taken place.

The Seal Kit includes all the o-rings, ball seals and thrust bearings that were originally installed at the factory. A sketch of these parts for most 2-way valves is provided at the right.

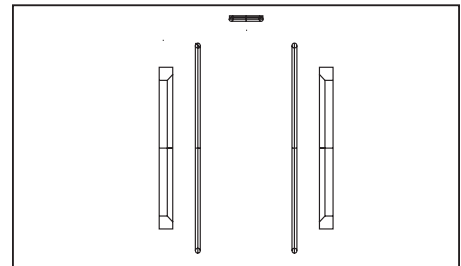

Ordering Information

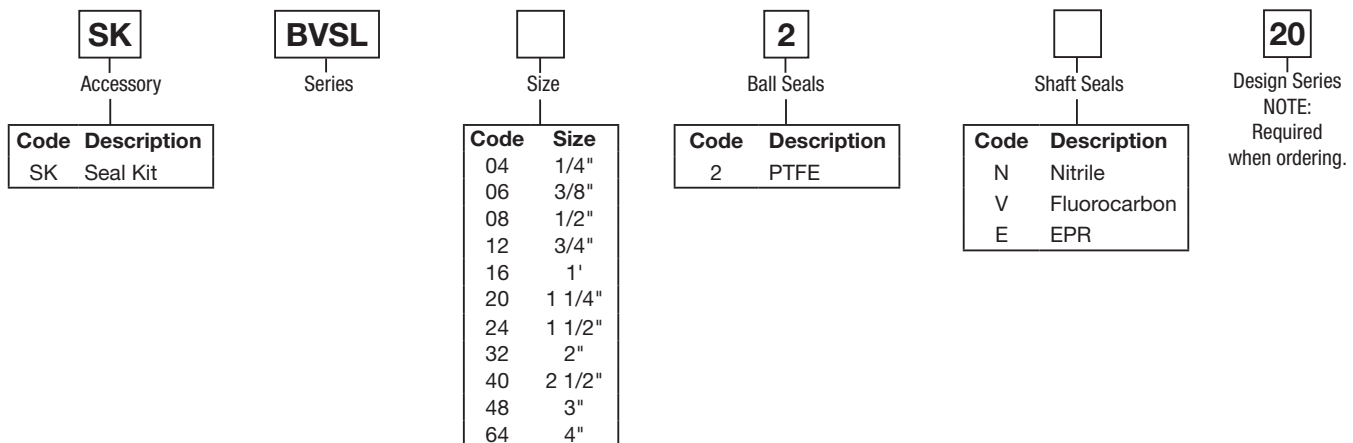

Threaded Ports Sizes 04 through 16

Inch equivalents for millimeter dimensions are shown in (**)

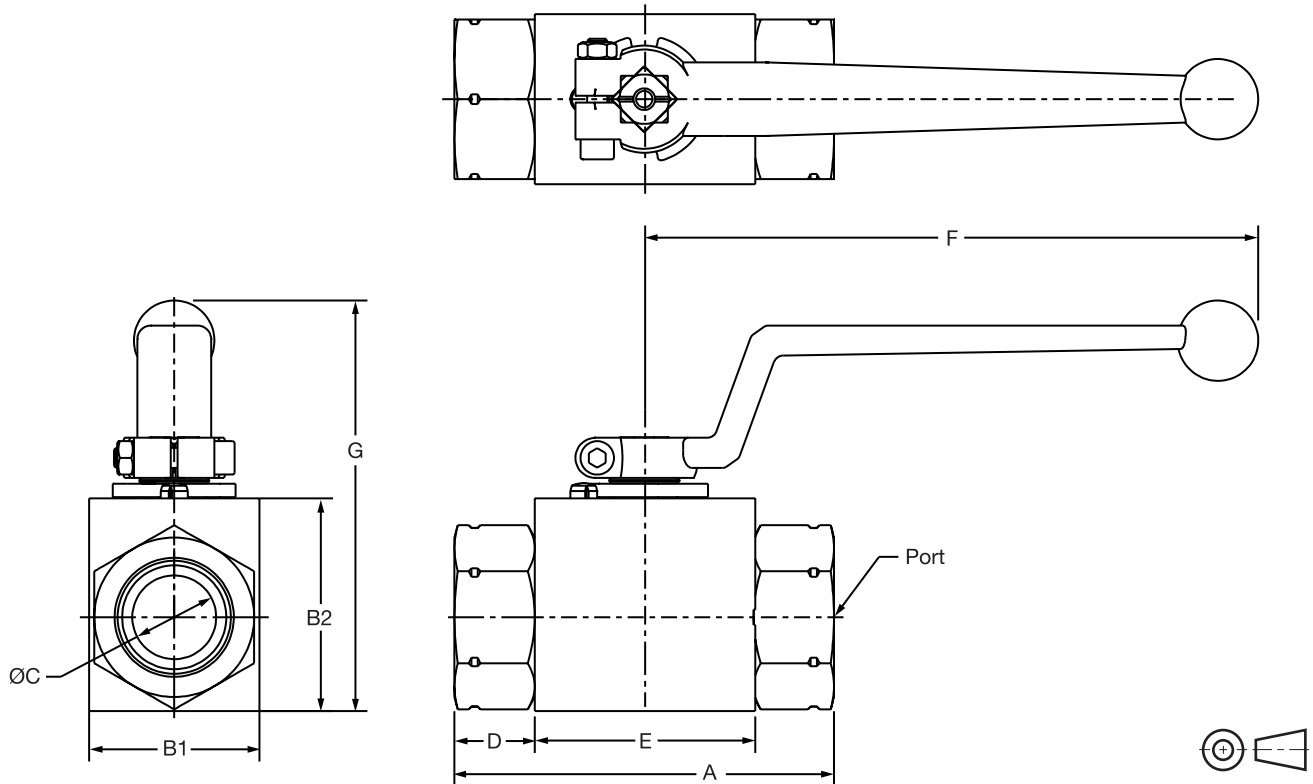

Code	Port Thread Size	Working Pressure	A	B1	B2	C	D	E	F	G
BVSL – NPT, SAE, and BSPP										
04	1/4"	100 Bar (1450 PSI)	68.9 (2.71)	31.75 (1.25)	38.1 (1.50)	10 (0.39)	12.9 (0.51)	43.1 (1.70)	117.1 (4.61)	86.25 (3.40)
06	3/8"	100 Bar (1450 PSI)	71.9 (2.83)	31.75 (1.25)	38.1 (1.50)	10 (0.39)	14.4 (0.57)	43.1 (1.70)	117.13 (4.61)	86.25 (3.40)
08	1/2"	100 Bar (1450 PSI)	82.5 (3.25)	31.75 (1.25)	38.1 (1.50)	13 (0.51)	17.25 (0.68)	48 (1.89)	117.07 (4.61)	86.45 (3.40)
12	3/4"	100 Bar (1450 PSI)	95.3 (3.75)	50.8 (2.00)	57.15 (2.25)	20 (0.79)	16.65 (0.66)	62 (2.44)	170 (6.69)	125.55 (4.94)
16	1"	70 Bar (1000 PSI)	113.1 (4.45)	50.8 (2.00)	63.5 (2.50)	25 (0.98)	23.45 (0.92)	66.2 (2.61)	170 (6.69)	131.9 (5.19)

Threaded Ports Sizes 20 through 32

Inch equivalents for millimeter dimensions are shown in (**)

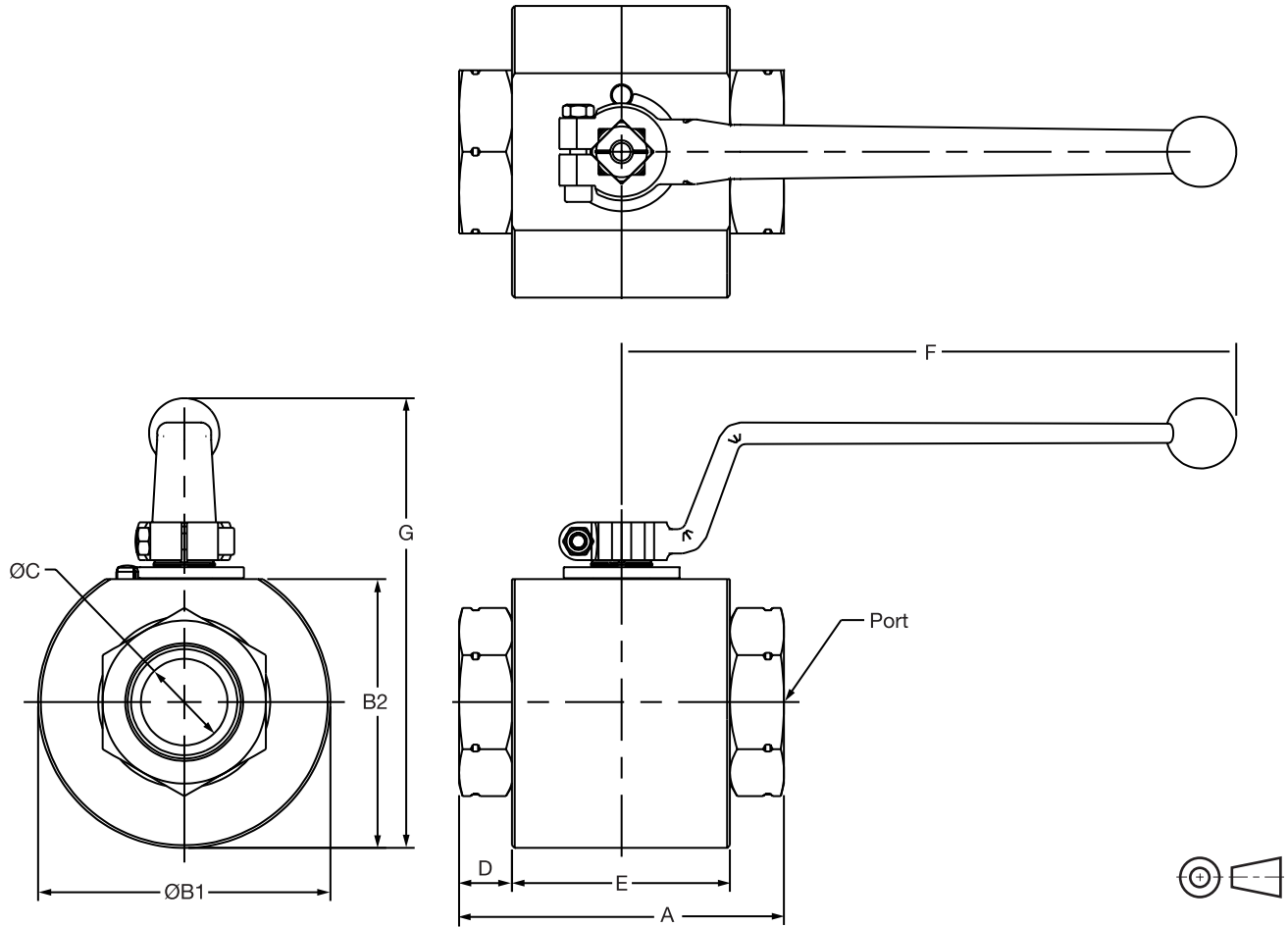

Code	Port Thread Size	Working Pressure	A	B1	B2	C	D	E	F	G
BVSL – NPT, SAE, and BSPP										
20	1-1/4"	70 Bar (1000 PSI)	120 (4.72)	82.55 (3.25)	80.33 (3.16)	32 (1.26)	19.49 (0.77)	80.51 (3.17)	170 (6.69)	155.47 (6.12)
24	1-1/2"	70 Bar (1000 PSI)	130 (5.12)	101.6 (4.00)	96.18 (3.79)	38 (1.50)	21.99 (0.87)	85.51 (3.37)	170 (6.69)	171.32 (6.74)
32	2"	70 Bar (1000 PSI)	139.8 (5.50)	107.95 (4.25)	104.04 (4.10)	48 (1.89)	19.39 (0.76)	100.51 (3.96)	170 (6.69)	179.18 (7.05)

Threaded Ports Sizes 40 through 64

Inch equivalents for millimeter dimensions are shown in (**)

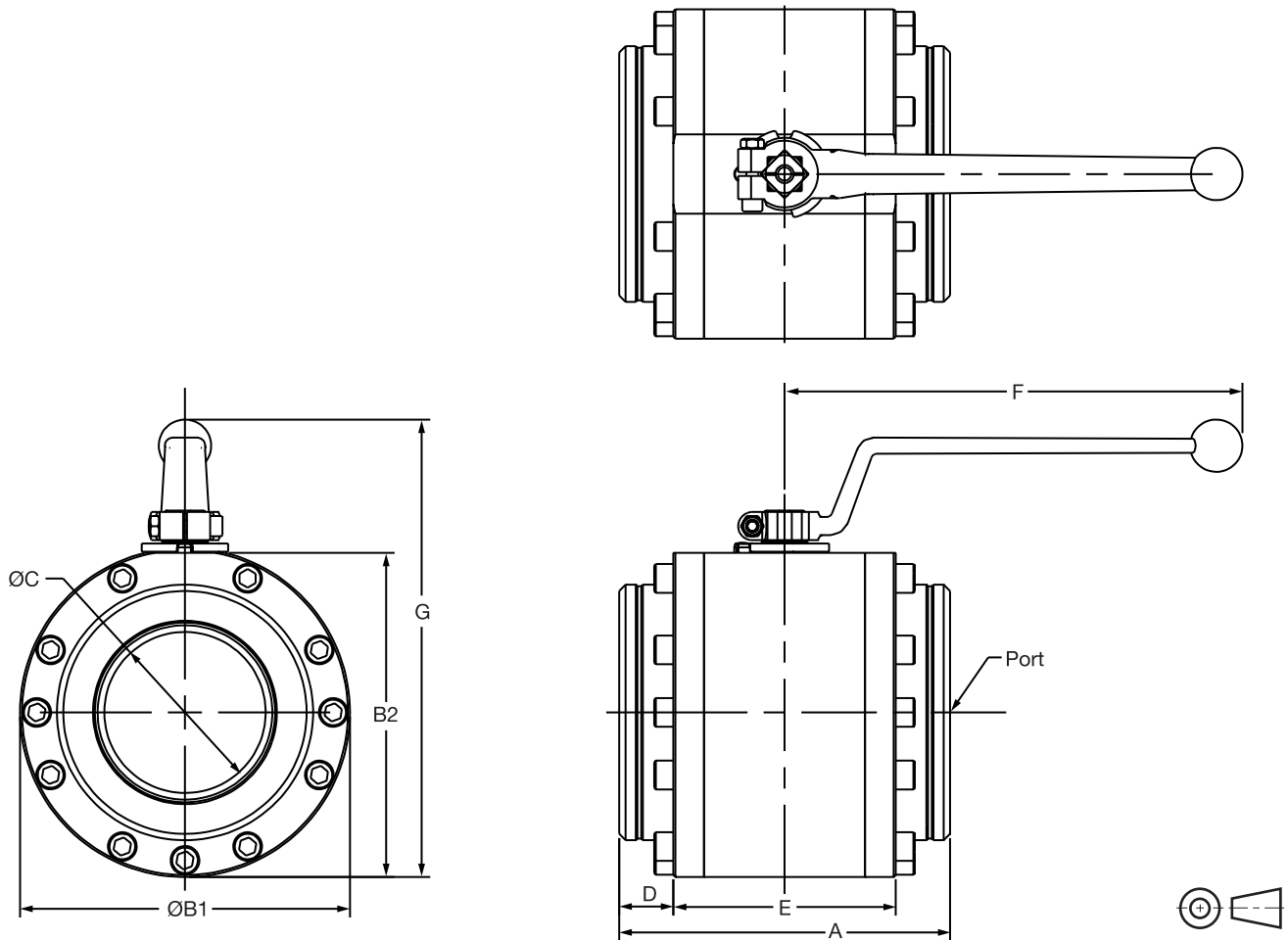

Code	Port Thread Size	Working Pressure	A	B1	B2	C	D	E	F	G
BVSL – NPT, SAE, and BSPP										
40	2-1/2"	50 Bar (725 PSI)	148.34 (5.84)	138.18 (5.44)	140.84 (5.54)	65 (2.56)	43.05 (1.69)	65.91 (2.59)	306 (12.00)	231.84 (9.13)
48	3"	50 Bar (725 PSI)	164.1 (6.46)	163.58 (6.44)	161.66 (6.36)	80 (3.15)	42.16 (1.66)	79.76 (3.14)	306 (12.00)	252.66 (9.95)
64	4"	50 Bar (725 PSI)	196.8 (7.75)	209.55 (8.25)	205.61 (8.09)	100 (3.94)	50.8 (2.00)	95.3 (3.75)	320 (12.60)	286.61 (11.30)

BVHPLK: Standard Series 'BVHPLK-*-*' kit replaces the stopwasher with a stationary and moving plate, as illustrated below. As the handle is actuated, the moving plate aligns with one of the two locking positions in the stationary plate, enabling the valve to be locked in either **fully closed** or **fully open** position.

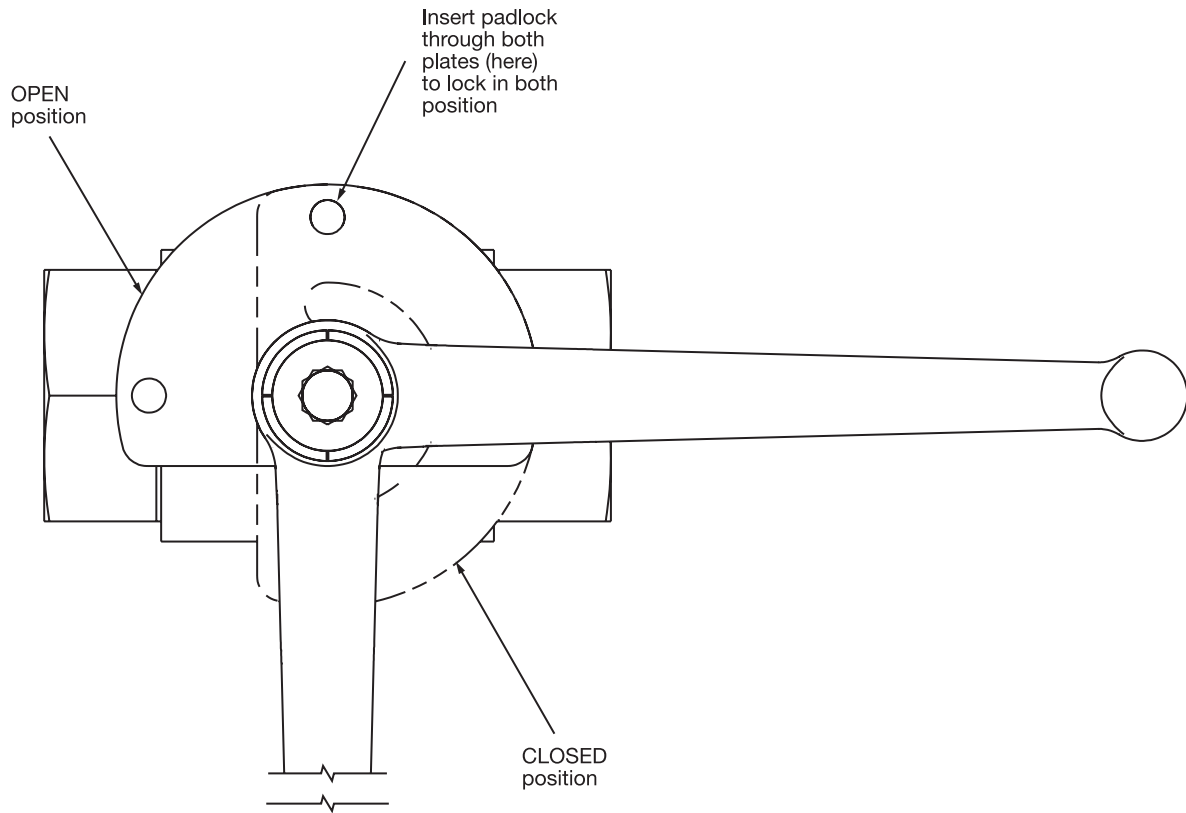

Ordering Information

BVSL		Standard Locking
Code	Size	(Part Number)
04	1/4"	BVHPLK-1-20
06	3/8"	BVHPLK-1-20
08	1/2"	BVHPLK-1-20
12	3/4"	BVHPLK-1-20
16	1"	BVHPLK-1-20
20	1 1/4"	BVHPLK-2-20
24	1 1/2"	BVHPLK-2-20
32	2"	BVHPLK-2-20
40	2 1/2"	BVHPLK-3-20
48	3"	BVHPLK-3-20
64	4"	BVHPLK-3-20

Ball Valve Sizing Chart (2-Way)

Parker's unrestricted bore ball valves provide a fluid path which, in most cases, imposes no discernable pressure drop in standard hydraulic circuits. As a result, you can treat our valves as just like a length of fluid line, unless you are working with closed loop or other circuits where a tiny pressure drop carries a price tag in heat generation, etc.

The selection chart at the right may be used as a guide for confirming your choice of ball valve fluid line size relative to the expected flow in LPM (GPM) at a given velocity.

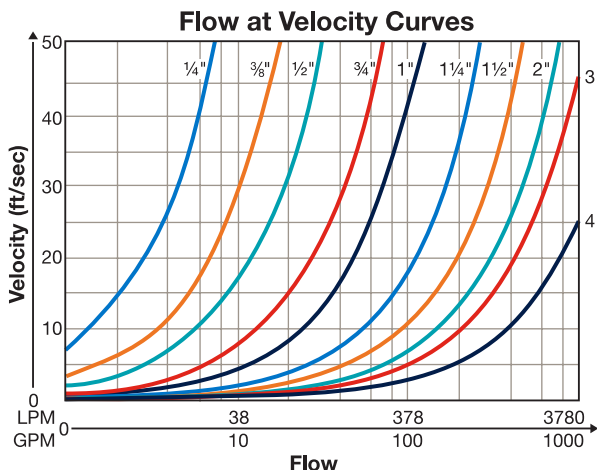

Ball Seals and Internal O-Rings

Standard Ball Seal Materials: Most application needs can be met by specifying one of the following ball seal materials:

- **Delrin™ Moly:** Standard with most ball valves. High pressure, moderate temperature range.
- **PTFE:** Excellent for suction and low pressure use. Inert to most substances and safe for food/water use.
- **Peek Hi-Temp:** Cost effective, provides additional temperature range up to 176.7°C (350°F). Best results with fluorocarbon sealing.

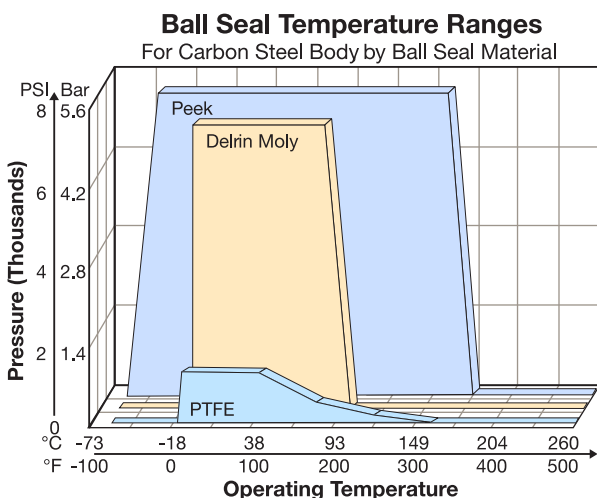

O-Ring and Backup Ring Material

- **Nitrile:** The industry standard for hydraulics using petroleum based fluids. Not suitable above 100°C (212°F).
- **EPR:** For use with Phosphate Esters (“Skydrol”), strong acids and bases, and other hostile media. Not compatible with petroleum based fluids. Good temperature range.
- **Fluorocarbon:** Extends temperature range to 350°F (176.7°C) with most Nitrile compatible media. Somewhat resistant to hostile media.

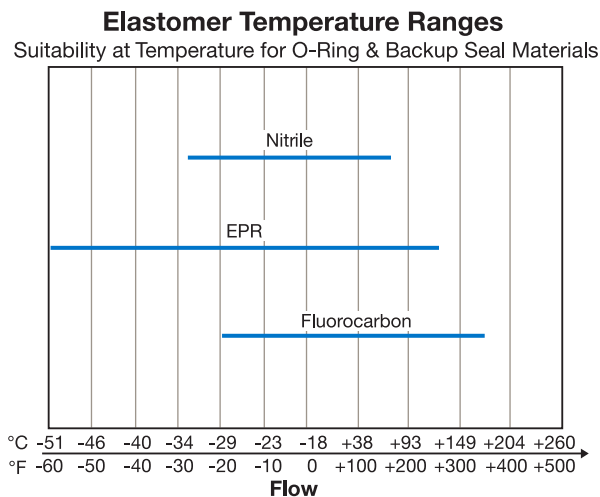

Sealing Materials Technical Data

Never operate Parker Ball Valves outside the temperature range published below for your selected thermoplastic and elastomer materials, even if the combination is approved in the Media Acceptability Table. You may experience valve leakage or failure.

Order Code Description	Ball Seal Materials			O-Ring & Backup Seal Materials		
	1 Delrin™ Moly	2 PTFE	4 PEEK Hi-Temp	N Nitrile	E EPR	V Fluorocarbon
Temperature Range	-30°C to +100°C (-22°F to +212°F)	-60°C to +180°C (-76°F to +356°F)	-40°C to +250°C (-40°F to +482°F)	-30°C to +100°C (-22°F to +212°F)	-50°C to +150°C (-58°F to +302°F)	-25°C to +250°C (-13°F to +482°F)
Seal Compound Identification	Delrin+MoS2 Polyoxymethylene impregnated with diene rubber Molybdenum Disulphide	Polytetra- fluoroethylene	Polyether-ether- ketone	Nitrile Butadiene rubber	Ethylene- polypropylene- diene rubber	Fluoropropylene methylene
Acronym	DM	PTFE	PEEK	NBR	EPR EPDM	FPM
Classification Synthesis	Thermoplast Saturated heteropolymer of heterogeneous polymer chains compounded with sulphide of molyb- denum metal for lubrication	Thermoplast Homogeneous, pure polymer chains, containing fluorine	Thermoplast Aromatic linear polymer	Elastomer Unsaturated heteropolymer compounded from acrylonitrile and butadiene	Elastomer Saturated heteropolymer utilizing double valence bands outside the primary chain	Elastomer Multiple monomers & fluorine compounded into saturated hetero- polymer
Commercial Trade Names	Made to Parker's specifications	PTFE Hostafion Fluon	Victrex	Nitrile Perbunan Chemigum Elaprim Krynac	Buna AP Dutral Epcar Keltran Nordel	Viton Fluorel Technoflon
Chemical Resistance Examples						
Suitable	Hydraulic fluids Water Inert Gases Air Alcohols Glycols Petroleum based fluids	Foodstuffs Acids & Alkalis Organic & inorganic solvents	Most fluids acceptable with Delrin Moly	Hydraulic fluids (except Skydrol) Water Air Petroleum based fluids	Phosphate esters Brake fluid Acids & Alkalis	NBR compatible fluids Acids & Alkalis
Not Suitable	High molar acids & alkalis Fluorines Liquids for human consumption	Fluorines Liquid alkali metals	High molar acids & alkalis	Phosphate esters	Petroleum based oil & grease Chlorinated hydrocarbons	Phosphate esters

Terms of Sale with Warranty Limitations

PARKER-HANNIFIN CORPORATION — HYDRAULIC VALVE DIVISION OFFER OF SALE

- 1. Definitions.** As used herein, the following terms have the meanings indicated.
- Buyer:** means any customer receiving a Quote for Products from Seller.
- Goods:** means any tangible part, system or component to be supplied by the Seller.
- Products:** means the Goods, Services and/or Software as described in a Quote provided by the Seller.
- Quote:** means the offer or proposal made by Seller to Buyer for the supply of Products.
- Seller:** means Parker-Hannifin Corporation, including all divisions and businesses thereof.
- Services:** means any services to be supplied by the Seller.
- Software:** means any software related to the Products, whether embedded or separately downloaded.
- Terms:** means the terms and conditions of this Offer of Sale or any newer version of the same as published by Seller electronically at www.parker.com/saleterms.
- 2. Terms.** All sales of Products by Seller are contingent upon, and will be governed by, these Terms and, these Terms are incorporated into any Quote provided by Seller to any Buyer. Buyer's order for any Products whether communicated to Seller verbally, in writing, by electronic data interface or other electronic commerce, shall constitute acceptance of these Terms. Seller objects to any contrary or additional terms or conditions of Buyer. Reference in Seller's order acknowledgement to Buyer's purchase order or purchase order number shall in no way constitute an acceptance of any of Buyer's terms of purchase. No modification to these Terms will be binding on Seller unless agreed to in writing and signed by an authorized representative of Seller.
- 3. Price; Payment.** The Products set forth in Seller's Quote are offered for sale at the prices indicated in Seller's Quote. Unless otherwise specifically stated in Seller's Quote, prices are valid for thirty (30) days and do not include any sales, use, or other taxes or duties. Seller reserves the right to modify prices at any time to adjust for any raw material price fluctuations. Unless otherwise specified by Seller, all prices are F.C.A. Seller's facility (INCOTERMS 2010). All sales are contingent upon credit approval and payment for all purchases is due thirty (30) days from the date of invoice (or such date as may be specified in the Quote). Unpaid invoices beyond the specified payment date incur interest at the rate of 1.5% per month or the maximum allowable rate under applicable law.
- 4. Shipment; Delivery; Title and Risk of Loss.** All delivery dates are approximate. Seller is not responsible for damages resulting from any delay. Regardless of the manner of shipment, delivery occurs and title and risk of loss or damage pass to Buyer, upon placement of the Products with the shipment carrier at Seller's facility. Unless otherwise agreed, Seller may exercise its judgment in choosing the carrier and means of delivery. No deferment of shipment at Buyer's request beyond the respective indicated shipping date will be made except on terms that will indemnify, defend and hold Seller harmless against all loss and additional expense. Buyer shall be responsible for any additional shipping charges incurred by Seller due to Buyer's acts or omissions.
- 5. Warranty.** The warranty related to the Products is as follows: (i) Goods are warranted against defects in material or workmanship for a period of eighteen (18) months from the date of delivery; (ii) Services shall be performed in accordance with generally accepted practices and using the degree of care and skill that is ordinarily exercised and customary in the field to which the Services pertain and are warranted for a period of six (6) months from the completion of the Services by Seller; and (iii) Software is only warranted to perform in accordance with applicable specifications provided by Seller to Buyer for ninety (90) days from the date of delivery or, when downloaded by a Buyer or end-user, from the date of the initial download. All prices are based upon the exclusive limited warranty stated above, and upon the following disclaimer:
- DISCLAIMER OF WARRANTY: THIS WARRANTY IS THE SOLE AND ENTIRE WARRANTY PERTAINING TO PRODUCTS. SELLER DISCLAIMS ALL OTHER WARRANTIES, EXPRESS AND IMPLIED, INCLUDING DESIGN, NON-INFRINGEMENT, MERCHANTABILITY, AND FITNESS FOR A PARTICULAR PURPOSE. SELLER DOES NOT WARRANT THAT THE SOFTWARE IS ERROR-FREE OR FAULT-TOLERANT, OR THAT BUYER'S USE THEREOF WILL BE SECURE OR UNINTERRUPTED. BUYER AGREES AND ACKNOWLEDGES THAT UNLESS OTHERWISE AUTHORIZED IN WRITING BY SELLER THE SOFTWARE SHALL NOT BE USED IN CONNECTION WITH HAZARDOUS OR HIGH RISK ACTIVITIES OR ENVIRONMENTS. EXCEPT AS EXPRESSLY STATED HEREIN, ALL PRODUCTS ARE PROVIDED "AS IS".**
- 6. Claims; Commencement of Actions.** Buyer shall promptly inspect all Products upon receipt. No claims for shortages will be allowed unless reported to the Seller within ten (10) days of delivery. Buyer shall notify Seller of any alleged breach of warranty within thirty (30) days after the date the non-conformance is or should have been discovered by Buyer. Any claim or action against Seller based upon breach of contract or any other theory, including tort, negligence, or otherwise must be commenced within twelve (12) months from the date of the alleged breach or other alleged event, without regard to the date of discovery.
- 7. LIMITATION OF LIABILITY.** IN THE EVENT OF A BREACH OF WARRANTY, SELLER WILL, AT ITS OPTION, REPAIR OR REPLACE THE NON-CONFORMING PRODUCT, RE-PERFORM THE SERVICES, OR REFUND THE PURCHASE PRICE PAID WITHIN A REASONABLE PERIOD OF TIME. IN NO EVENT IS SELLER LIABLE FOR ANY SPECIAL, INDIRECT, INCIDENTAL OR CONSEQUENTIAL DAMAGES ARISING OUT OF, OR AS THE RESULT OF, THE SALE, DELIVERY, NON-DELIVERY, SERVICING, NON-COMPLETION OF SERVICES, USE, LOSS OF USE OF, OR INABILITY TO USE THE PRODUCTS OR ANY PART THEREOF, LOSS OF DATA, IDENTITY, PRIVACY, OR CONFIDENTIALITY, OR FOR ANY CHARGES OR EXPENSES OF ANY NATURE INCURRED WITHOUT SELLER'S WRITTEN CONSENT, WHETHER BASED IN CONTRACT, TORT OR OTHER LEGAL THEORY. IN NO EVENT SHALL SELLER'S LIABILITY UNDER ANY CLAIM MADE BY BUYER EXCEED THE PURCHASE PRICE PAID FOR THE PRODUCTS.
- 8. Loss to Buyer's Property.** Any designs, tools, patterns, materials, drawings, confidential information or equipment furnished by Buyer or any other items which are or become Buyer's property, will be considered obsolete and may be destroyed by Seller after two (2) consecutive years have elapsed without Buyer ordering the Products manufactured using such property. Seller shall not be responsible for any loss or damage to such property while it is in Seller's possession or control.
- 9. Special Tooling.** Special Tooling includes but is not limited to tooling, jigs, fixtures and associated manufacturing equipment acquired or necessary to manufacture Products. A tooling charge may be imposed for any Special Tooling. Such Special Tooling shall be and remain Seller's property notwithstanding payment of any charges by Buyer. In no event will Buyer acquire any interest in Special Tooling belonging to Seller that is utilized in the manufacture of the Products, even if such Special Tooling has been specially converted or adapted for such manufacture and notwithstanding any charges paid by Buyer. Unless otherwise agreed, Seller has the right to alter, discard or otherwise dispose of any Special Tooling or other property in its sole discretion at any time.
- 10. Security Interest.** To secure payment of all sums due, Seller retains a security interest in all Products delivered to Buyer and, Buyer's acceptance of these Terms is deemed to be a Security Agreement under the Uniform Commercial Code. Buyer authorizes Seller as its attorney to execute and file on Buyer's behalf all documents Seller deems necessary to perfect its security interest.
- 11. User Responsibility.** The Buyer through its own analysis and testing, is solely responsible for making the final selection of the Products and assuring that all performance, endurance, maintenance, safety and warning requirements of the application of the Products are met. The Buyer must analyze all aspects of the application and follow applicable industry standards, specifications, and other technical information provided with the Product. If Seller provides Product options based upon data or specifications provided by the Buyer, the Buyer is responsible for determining that such data and specifications are suitable and sufficient for all applications and reasonably foreseeable uses of the Products. In the event the Buyer is not the end-user, Buyer will ensure such end-user complies with this paragraph.
- 12. Use of Products, Indemnity by Buyer.** Buyer shall comply with all instructions, guides and specifications provided by Seller with the Products. Unauthorized Uses. If Buyer uses or resells the Products for any uses prohibited in Seller's instructions, guides or specifications, or Buyer otherwise fails to comply with Seller's instructions, guides and specifications, Buyer acknowledges that any such use, resale, or non-compliance is at Buyer's sole risk. Buyer shall indemnify, defend, and hold Seller harmless from any losses, claims, liabilities, damages, lawsuits, judgments and costs (including attorney fees and defense costs), whether for personal injury, property damage, intellectual property infringement or any other claim, brought by or incurred by Buyer, Buyer's employees, or any other person, arising out of: (a) improper selection, application, design, specification or other misuse of Products provided by Seller; (b) any act or omission, negligent or otherwise, of Buyer; (c) Seller's use of patterns, tooling, equipment, plans, drawings, designs or specifications or other information or things furnished by Buyer; (d) damage to the Products from an external cause, repair or attempted repair by anyone other than Seller, failure to follow instructions, guides and specifications provided by Seller, use with goods not provided by Seller, or opening, modifying, deconstructing or tampering with the Products for any reason; or (e) Buyer's failure to comply with these Terms. Seller shall not indemnify Buyer under any circumstance except as otherwise provided in these Terms.
- 13. Cancellations and Changes.** Buyer may not cancel or modify any order for any reason, except with Seller's written consent and upon terms that will indemnify, defend and hold Seller harmless against all direct, incidental and consequential loss or damage. Seller, at any time, may change Product features, specifications, designs and availability.
- 14. Limitation on Assignment.** Buyer may not assign its rights or obligations without the prior written consent of Seller.
- 15. Force Majeure.** Seller does not assume the risk and is not liable for delay or failure to perform any of Seller's obligations by reason of events or circumstances beyond its reasonable control ("Events of Force Majeure"). Events of Force Majeure shall include without limitation: accidents, strikes or labor disputes, acts of any government or government agency, acts of nature, delays or failures in delivery from carriers or suppliers, shortages of materials, or any other cause beyond Seller's reasonable control.
- 16. Waiver and Severability.** Failure to enforce any provision of these Terms will not invalidate that provision; nor will any such failure prejudice Seller's right to enforce that provision in the future. Invalidation of any provision of these Terms by legislation or other rule of law shall not invalidate any other provision herein and, the remaining provisions will remain in full force and effect.
- 17. Termination.** Seller may terminate any agreement governed by or arising from these Terms for any reason and at any time by giving Buyer thirty (30) days prior written notice. Seller may immediately terminate, in writing, if Buyer: (a) breaches any provision of these Terms (b) appoints a trustee, receiver or custodian for all or any part of Buyer's property (c) files a petition for relief in bankruptcy on its own behalf, or one if filed by a third party (d) makes an assignment for the benefit of creditors; or (e) dissolves its business or liquidates all or a majority of its assets.
- 18. Ownership of Software.** Seller retains ownership of all Software supplied to Buyer hereunder. In no event shall Buyer obtain any greater right in and to the Software than a right in the nature of a license limited to the use thereof and subject to compliance with any other terms provided with the Software.
- 19. Indemnity for Infringement of Intellectual Property Rights.** Seller is not liable for infringement of any patents, trademarks, copyrights, trade dress, trade secrets or similar rights ("Intellectual Property Rights") except as provided in this Section. Seller will defend at its expense and will pay the cost of any settlement or damages awarded in an action brought against Buyer based on a third party claim that one or more of the Products sold hereunder infringes the Intellectual Property Rights of a third party in the country of delivery of the Products by the Seller to the Buyer. Seller's obligation to defend and indemnify Buyer is contingent on Buyer notifying Seller within ten (10) days after Buyer becomes aware of any such claim, and Seller having sole control over the defense of the claim including all negotiations for settlement or compromise. If one or more Products sold hereunder is subject to such a claim, Seller may, at its sole expense and option, procure for Buyer the right to continue using the Products, replace or modify the Products so as to render them non-infringing, or offer to accept return of the Products and refund the purchase price less a reasonable allowance for depreciation. Seller has no obligation or liability for any claim of infringement: (i) arising from information provided by Buyer; or (ii) directed to any Products provided hereunder for which the designs are specified in whole or part by Buyer; or (iii) resulting from the modification, combination or use in a system of any Products provided hereunder. The foregoing provisions of this Section constitute Seller's sole and exclusive liability and Buyer's sole and exclusive remedy for such claims of infringement of Intellectual Property Rights.
- 20. Governing Law.** These Terms and the sale and delivery of all Products are deemed to have taken place in, and shall be governed and construed in accordance with, the laws of the State of Ohio, as applicable to contracts executed and wholly performed therein and without regard to conflicts of laws principles. Buyer irrevocably agrees and consents to the exclusive jurisdiction and venue of the courts of Cuyahoga County, Ohio with respect to any dispute, controversy or claim arising out of or relating to the sale and delivery of the Products.
- 21. Entire Agreement.** These Terms, along with the terms set forth in the main body of any Quote, forms the entire agreement between the Buyer and Seller and constitutes the final, complete and exclusive expression of the terms of sale. In the event of a conflict between any term set forth in the main body of a Quote and these Terms, the terms set forth in the main body of the Quote shall prevail. All prior or contemporaneous written or oral agreements or negotiations with respect to the subject matter shall have no effect. These Terms may not be modified unless in writing and signed by an authorized representative of Seller.
- 22. Compliance with Laws.** Buyer agrees to comply with all applicable laws, regulations, and industry and professional standards, including those of the United States of America, and the country or countries in which Buyer may operate, including without limitation the U.S. Foreign Corrupt Practices Act ("FCPA"), the U.S. Anti-Kickback Act ("Anti-Kickback Act"), U.S. and E.U. export control and sanctions laws ("Export Laws"), the U.S. Food Drug and Cosmetic Act ("FDCA"), and the rules and regulations promulgated by the U.S. Food and Drug Administration ("FDA"), each as currently amended. Buyer agrees to indemnify, defend, and hold harmless Seller from the consequences of any violation of such laws, regulations and standards by Buyer, its employees or agents. Buyer acknowledges that it is familiar with all applicable provisions of the FCPA, the Anti-Kickback Act, Export Laws, the FDCA and the FDA and certifies that Buyer will adhere to the requirements thereof and not take any action that would make Seller violate such requirements. Buyer represents and agrees that Buyer will not make any payment or give anything of value, directly or indirectly, to any governmental official, foreign political party or official thereof, candidate for foreign political office, or commercial entity or person, for any improper purpose, including the purpose of influencing such person to purchase Products or otherwise benefit the business of Seller. Buyer further represents and agrees that it will not receive, use, service, transfer or ship any Product from Seller in a manner or for a purpose that violates Export Laws or would cause Seller to be in violation of Export Laws.

5/17





Parker Safety Guide for Selecting and Using Hose, Tubing, Fittings and Related Accessories

Publication No. 4400-B.1

Revised: October 2015, Rev A

WARNING: Failure or improper selection or improper use of hose, tubing, fittings, assemblies, valves, connectors, conductors or related accessories (“Products”) can cause death, personal injury and property damage. Possible consequences of failure or improper selection or improper use of these Products include but are not limited to:

- Fittings thrown off at high speed.
- High velocity fluid discharge.
- Explosion or burning of the conveyed fluid.
- Electrocutation from high voltage electric powerlines.
- Contact with suddenly moving or falling objects that
- are controlled by the conveyed fluid.
- Injections by high-pressure fluid discharge.

- Dangerously whipping Hose.
- Tube or pipe burst.
- Weld joint fracture.
- Contact with conveyed fluids that may be hot, cold, toxic or otherwise injurious.
- Sparking or explosion caused by static electricity buildup or other sources of electricity.
- Sparking or explosion while spraying paint or flammable liquids.
- Injuries resulting from inhalation, ingestion or exposure to fluids.

Before selecting or using any of these Products, it is important that you read and follow the instructions below. No product from any division in Parker Fluid Connectors Group is approved for in-flight aerospace applications. For hoses and fittings used in in-flight aerospace applications, please contact Parker Aerospace Group.

1.0 GENERAL INSTRUCTIONS

1.1 Scope: This safety guide provides instructions for selecting and using (including assembling, installing, and maintaining) these Products. For convenience, all rubber and/or thermoplastic products commonly called “hose” or “tubing” are called “Hose” in this safety guide. Metallic tube or pipe are called “tube”. All assemblies made with Hose are called “Hose Assemblies”. All assemblies made with Tube are called “Tube Assemblies”.

All products commonly called “fittings”, “couplings” or “adapters” are called “Fittings”. Valves are fluid system components that control the passage of fluid. Related accessories are ancillary devices that enhance or monitor performance including crimping, flaring, flanging, presetting, bending, cutting, deburring, swaging machines, sensors, tags, lockout handles, spring guards and associated tooling. This safety guide is a supplement to and is to be used with the specific Parker publications for the specific Hose, Fittings and Related Accessories that are being considered for use. Parker publications are available at www.parker.com. SAE J1273 (www.sae.org) and ISO 17165-2 (www.ansi.org) also provide recommended practices for hydraulic Hose Assemblies, and should be followed.

1.2 Fail-Safe: Hose, Hose Assemblies, Tube, Tube Assemblies and Fittings can and do fail without warning for many reasons. Design all systems and equipment in a fail-safe mode, so that failure of the Hose, Hose Assembly, Tube, Tube Assembly or Fitting will not endanger persons or property.

1.3 Distribution: Provide a copy of this safety guide to each person responsible for selecting or using Hose, Tube and Fitting products. Do not select or use Parker Hose, Tube or Fittings without thoroughly reading and understanding this safety guide as well as the specific Parker publications for the Products.

1.4 User Responsibility: Due to the wide variety of operating conditions and applications for Hose, Tube and Fittings. Parker does not represent or warrant that any particular Hose, Tube or Fitting is suitable for any specific end use system. This safety guide does not analyze all technical parameters that must be considered in selecting a product. The user, through its own analysis and testing, is solely responsible for:

- Making the final selection of the Products.
- Assuring that the user’s requirements are met and that the application presents no health or safety hazards.
- Following the safety guide for Related Accessories and being trained to operate Related Accessories.
- Providing all appropriate health and safety warnings on the equipment on which the Products are used.
- Assuring compliance with all applicable government and industry standards.

1.5 Additional Questions: Call the appropriate Parker technical service department if you have any questions or require any additional information. See the Parker publication for the Products being considered or used, or call 1-800-CPARKER, or go to www.parker.com, for telephone numbers of the appropriate technical service department.

2.0 HOSE, TUBE & FITTINGS SELECTION INSTRUCTIONS

2.1 Electrical Conductivity: Certain applications require that the Hose be nonconductive to prevent electrical current flow. Other applications require the Hose and the Fittings and the Hose/Fitting interface to be sufficiently conductive to drain off static electricity. Extreme care must be exercised when selecting Hose, Tube and Fittings for these or any other applications in which electrical conductivity or nonconductivity is a factor.

The electrical conductivity or nonconductivity of Hose, Tube and Fittings is dependent upon many factors and may be susceptible to change. These factors include but are not limited to the various materials used to make the Hose and the Fittings, Fitting finish (some Fitting finishes are electrically conductive while others are nonconductive), manufacturing methods (including moisture control), how the Fittings contact the Hose, age and amount of deterioration or damage or other changes, moisture content of the Hose at any particular time, and other factors.

The following are considerations for electrically nonconductive and conductive Hose. For other applications consult the individual catalog pages and the appropriate industry or regulatory standards for proper selection.

2.1.1 Electrically Nonconductive Hose: Certain applications require that the Hose be nonconductive to prevent electrical current flow or to maintain electrical isolation. For applications that require Hose to be electrically nonconductive, including but not limited to applications near high voltage electric lines, only special nonconductive Hose can be used. The manufacturer of the equipment in which the nonconductive Hose is to be used must be consulted to be certain that the Hose, Tube and Fittings that are selected are proper for the application. Do not use any Parker Hose or Fittings for any such application requiring nonconductive Hose, including but not limited to applications near high voltage electric lines or dense magnetic fields, unless (i) the application is expressly approved in the Parker technical publication for the product, (ii) the Hose is marked “nonconductive”, and (iii) the manufacturer of the equipment on which the Hose is to be used specifically approves the particular Parker Hose, Tube and Fittings for such use.

2.1.2 Electrically Conductive Hose: Parker manufactures special Hose for certain applications that require electrically conductive Hose. Parker manufactures special Hose for conveying paint in airless paint spraying applications. This Hose is labeled “Electrically Conductive Airless Paint Spray Hose” on its layline and packaging. This Hose must be properly connected to the appropriate Parker Fittings and properly grounded in order to dissipate dangerous static charge buildup, which occurs in all airless paint spraying applications. Do not use any other Hose for airless paint spraying, even if electrically conductive. Use of any other Hose or failure to properly connect the Hose can cause a fire or an explosion resulting in death, personal injury, and property damage. All hoses that convey fuels must be grounded.

Parker manufactures a special Hose for certain compressed natural gas (“CNG”) applications where static electricity buildup may occur. Parker CNG Hose assemblies comply with the requirements of ANSI/IAS NGV 4.2; CSA 12.52, “Hoses for Natural Gas Vehicles and Dispensing Systems” (www.ansi.org). This Hose is labeled “Electrically Conductive for CNG Use” on its layline and packaging. This Hose must be properly connected to the appropriate Parker Fittings and properly grounded in order to dissipate dangerous static charge buildup, which occurs in, for example, high velocity CNG dispensing or transfer. Do not use any other Hose for CNG applications where static charge buildup may occur, even if electrically conductive. Use of other Hoses in CNG applications or failure to properly connect or ground this Hose can cause a fire or an explosion resulting in death, personal injury, and property damage. Care must also be taken to protect against CNG permeation through the Hose wall. See section 2.6, Permeation, for more information. Parker CNG Hose is intended for dispenser and vehicle use within the specified temperature range. Parker CNG Hose should not be used in confined spaces or unventilated areas or areas exceeding the specified temperature range.

Parker Safety Guide (Continued)

Final assemblies must be tested for leaks. CNG Hose Assemblies should be tested on a monthly basis for conductivity per ANSI/ASME NGV 4.2; CSA 12.52.

Parker manufactures special Hose for aerospace in-flight applications. Aerospace in-flight applications employing Hose to transmit fuel, lubricating fluids and hydraulic fluids require a special Hose with a conductive inner tube. This Hose for in-flight applications is available only from Parker's Stratoflex Products Division. Do not use any other Parker Hose for in-flight applications, even if electrically conductive. Use of other Hoses for in-flight applications or failure to properly connect or ground this Hose can cause a fire or an explosion resulting in death, personal injury and property damage. These Hose assemblies for in-flight applications must meet all applicable aerospace industry, aircraft engine and aircraft requirements.

2.2 Pressure: Hose, Tube and Fitting selection must be made so that the published maximum working pressure of the Hose, Tube and Fittings are equal to or greater than the maximum system pressure. The maximum working pressure of a Hose, or Tube Assembly is the lower of the respective published maximum working pressures of the Hose, Tube and the Fittings used. Surge pressures or peak transient pressures in the system must be below the published maximum working pressure for the Hose, Tube and Fitting. Surge pressures and peak pressures can usually only be determined by sensitive electrical instrumentation that measures and indicates pressures at millisecond intervals. Mechanical pressure gauges indicate only average pressures and cannot be used to determine surge pressures or peak transient pressures. Published burst pressure ratings for Hose is for manufacturing test purposes only and is no indication that the Product can be used in applications at the burst pressure or otherwise above the published maximum recommended working pressure.

2.3 Suction: Hoses used for suction applications must be selected to insure that the Hose will withstand the vacuum and pressure of the system. Improperly selected Hose may collapse in suction application.

2.4 Temperature: Be certain that fluid and ambient temperatures, both steady and transient, do not exceed the limitations of the Hose, Tube, Fitting and Seals. Temperatures below and above the recommended limit can degrade Hose, Tube, Fittings and Seals to a point where a failure may occur and release fluid. Tube and Fittings performances are normally degraded at elevated temperature. Material compatibility can also change at temperatures outside of the rated range. Properly insulate and protect the Hose Assembly when routing near hot objects (e.g. manifolds). Do not use any Hose in any application where failure of the Hose could result in the conveyed fluids (or vapors or mist from the conveyed fluids) contacting any open flame, molten metal, or other potential fire ignition source that could cause burning or explosion of the conveyed fluids or vapors.

2.5 Fluid Compatibility: Hose, and Tube Assembly selection must assure compatibility of the Hose tube, cover, reinforcement, Tube, Plating and Seals with the fluid media used. See the fluid compatibility chart in the Parker publication for the product being considered or used. This information is offered only as a guide. Actual service life can only be determined by the end user by testing under all extreme conditions and other analysis.

Hose, and Tube that is chemically compatible with a particular fluid must be assembled using Fittings and adapters containing likewise compatible seals. Flange or flare processes can change Tube material properties that may not be compatible with certain requirements such as NACE.

2.6 Permeation: Permeation (that is, seepage through the Hose or Seal) will occur from inside the Hose or Fitting to outside when Hose or Fitting is used with gases, liquid and gas fuels, and refrigerants (including but not limited to such materials as helium, diesel fuel, gasoline, natural gas, or LPG). This permeation may result in high concentrations of vapors which are potentially flammable, explosive, or toxic, and in loss of fluid. Dangerous explosions, fires, and other hazards can result when using the wrong Hose for such applications. The system designer must take into account the fact that this permeation will take place and must not use Hose or Fitting if this permeation could be hazardous. The system designer must take into account all legal, government, insurance, or any other special regulations which govern the use of fuels and refrigerants. Never use a Hose or Fitting even though the fluid compatibility is acceptable without considering the potential hazardous effects that can result from permeation through the Hose or Tube Assembly. Permeation of moisture from outside the Hose or Fitting to

inside the Hose or Fitting will also occur in Hose or Tube assemblies, regardless of internal pressure. If this moisture permeation would have detrimental effects (particularly, but not limited to refrigeration and air conditioning systems), incorporation of sufficient drying capacity in the system or other appropriate system safeguards should be selected and used. The sudden pressure release of highly pressurized gas could also result in Explosive Decompression failure of permeated Seals and Hoses.

2.7 Size: Transmission of power by means of pressurized fluid varies with pressure and rate of flow. The size of the components must be adequate to keep pressure losses to a minimum and avoid damage due to heat generation or excessive fluid velocity.

2.8 Routing: Attention must be given to optimum routing to minimize inherent problems (kinking or flow restriction due to Hose collapse, twisting of the Hose, proximity to hot objects or heat sources). For additional routing recommendations see SAE J1273 and ISO 17165-2. Hose Assemblies have a finite life and should be installed in a manner that allows for ease of inspection and future replacement. Hose because of its relative short life, should not be used in residential and commercial buildings inside of inaccessible walls or floors, unless specifically allowed in the product literature. Always review all product literature for proper installation and routing instructions.

2.9 Environment: Care must be taken to insure that the Hose, Tube and Fittings are either compatible with or protected from the environment (that is, surrounding conditions) to which they are exposed. Environmental conditions including but not limited to ultraviolet radiation, sunlight, heat, ozone, moisture, water, salt water, chemicals and air pollutants can cause degradation and premature failure.

2.10 Mechanical Loads: External forces can significantly reduce Hose, Tube and Fitting life or cause failure. Mechanical loads which must be considered include excessive flexing, twist, kinking, tensile or side loads, bend radius, and vibration. Use of swivel type Fittings or adapters may be required to insure no twist is put into the Hose. Use of proper Hose or Tube clamps may also be required to reduce external mechanical loads. Unusual applications may require special testing prior to Hose selection.

2.11 Physical Damage: Care must be taken to protect Hose from wear, snagging, kinking, bending smaller than minimum bend radius and cutting, any of which can cause premature Hose failure. Any Hose that has been kinked or bent to a radius smaller than the minimum bend radius, and any Hose that has been cut or is cracked or is otherwise damaged should be removed and discarded. Fittings with damages such as scratches on sealing surfaces and deformation should be replaced.

2.12 Proper End Fitting: See instructions 3.2 through 3.5. These recommendations may be substantiated by testing to industry standards such as SAE J517 for hydraulic applications, or MIL-A-5070, AS1339, or AS3517 for Hoses from Parker's Stratoflex Products Division for aerospace applications.

2.13 Length: When determining the proper Hose or Tube length of an assembly, be aware of Hose length change due to pressure, Tube length change due to thermal expansion or contraction, and Hose or Tube and machine tolerances and movement must be considered. When routing short hose assemblies, it is recommended that the minimum free hose length is always used. Consult the hose manufacturer for their minimum free hose length recommendations. Hose assemblies should be installed in such a way that any motion or flexing occurs within the same plane.

2.14 Specifications and Standards: When selecting Hose, Tube and Fittings, government, industry, and Parker specifications and recommendations must be reviewed and followed as applicable.

2.15 Hose Cleanliness: Hose and Tube components may vary in cleanliness levels. Care must be taken to insure that the Hose and Tube Assembly selected has an adequate level of cleanliness for the application.

2.16 Fire Resistant Fluids: Some fire resistant fluids that are to be conveyed by Hose or Tube require use of the same type of Hose or Tube as used with petroleum base fluids. Some such fluids require a special Hose, Tube, Fitting and Seal, while a few fluids will not work with any Hose at all. See instructions 2.5 and 1.5. The wrong Hose, Tube, Fitting or Seal may fail after a very short service. In addition, all liquids but pure water may burn fiercely under certain conditions, and even pure water leakage may be hazardous.

2.17 Radiant Heat: Hose and Seals can be heated to destruction without contact by such nearby items as hot manifolds or molten metal.

Parker Safety Guide (Continued)

The same heat source may then initiate a fire. This can occur despite the presence of cool air around the Hose or Seal. Performance of Tube and Fitting subjected to the heat could be degraded.

2.18 Welding or Brazing: When using a torch or arc welder in close proximity to hydraulic lines, the hydraulic lines should be removed or shielded with appropriate fire resistant materials. Flame or weld spatter could burn through the Hose or Seal and possibly ignite escaping fluid resulting in a catastrophic failure. Heating of plated parts, including Hose Fittings and adapters, above 450°F (232°C) such as during welding, brazing or soldering may emit deadly gases. Any elastomer seal on fittings shall be removed prior to welding or brazing, any metallic surfaces shall be protected after brazing or welding when necessary. Welding and brazing filler material shall be compatible with the Tube and Fitting that are joined.

2.19 Atomic Radiation: Atomic radiation affects all materials used in Hose and Tube assemblies. Since the long-term effects may be unknown, do not expose Hose or Tube assemblies to atomic radiation. Nuclear applications may require special Tube and Fittings.

2.20 Aerospace Applications: The only Hose, Tube and Fittings that may be used for in-flight aerospace applications are those available from Parker's Stratoflex Products Division. Do not use any other Hose or Fittings for in-flight applications. Do not use any Hose or Fittings from Parker's Stratoflex Products Division with any other Hose or Fittings, unless expressly approved in writing by the engineering manager or chief engineer of Stratoflex Products Division and verified by the user's own testing and inspection to aerospace industry standards.

2.21 Unlocking Couplings: Ball locking couplings or other Fittings with quick disconnect ability can unintentionally disconnect if they are dragged over obstructions, or if the sleeve or other disconnect member, is bumped or moved enough to cause disconnect. Threaded Fittings should be considered where there is a potential for accidental uncoupling.

3.0 HOSE AND FITTINGS ASSEMBLY AND INSTALLATION INSTRUCTIONS

3.1 Component Inspection: Prior to assembly, a careful examination of the Hose and Fittings must be performed. All components must be checked for correct style, size, catalog number, and length. The Hose must be examined for cleanliness, obstructions, blisters, cover looseness, kinks, cracks, cuts or any other visible defects. Inspect the Fitting and sealing surfaces for burrs, nicks, corrosion or other imperfections. Do NOT use any component that displays any signs of nonconformance.

3.2 Hose and Fitting Assembly: Do not assemble a Parker Fitting on a Parker Hose that is not specifically listed by Parker for that Fitting, unless authorized in writing by the engineering manager or chief engineer of the appropriate Parker division. Do not assemble a Parker Fitting on another manufacturer's Hose or a Parker Hose on another manufacturer's Fitting unless (i) the engineering manager or chief engineer of the appropriate Parker division approves the Assembly in writing or that combination is expressly approved in the appropriate Parker literature for the specific Parker product, and (ii) the user verifies the Assembly and the application through analysis and testing. For Parker Hose that does not specify a Parker Fitting, the user is solely responsible for the selection of the proper Fitting and Hose Assembly procedures. See instruction 1.4.

To prevent the possibility of problems such as leakage at the Fitting or system contamination, it is important to completely remove all debris from the cutting operation before installation of the Fittings. The Parker published instructions must be followed for assembling the Fittings on the Hose. These instructions are provided in the Parker Fitting catalog for the specific Parker Fitting being used, or by calling 1-800-CPARKER, or at www.parker.com.

3.3 Related Accessories: Do not crimp or swage any Parker Hose or Fitting with anything but the listed swage or crimp machine and dies in accordance with Parker published instructions. Do not crimp or swage another manufacturer's Fitting with a Parker crimp or swage die unless authorized in writing by the engineering manager or chief engineer of the appropriate Parker division.

3.4 Parts: Do not use any Parker Fitting part (including but not limited to socket, shell, nipple, or insert) except with the correct Parker mating parts, in accordance with Parker published instructions, unless authorized in writing by the engineering manager or chief engineer of the appropriate Parker division.

3.5 Field Attachable/Permanent: Do not reuse any field attachable Hose Fitting that has blown or pulled off a Hose. Do not reuse a Parker permanent Hose Fitting (crimped or swaged) or any part thereof. Complete Hose Assemblies may only be reused after proper inspection under section 4.0. Do not assemble Fittings to any previously used hydraulic Hose that was in service, for use in a fluid power application.

3.6 Pre-Installation Inspection: Prior to installation, a careful examination of the Hose Assembly must be performed. Inspect the Hose Assembly for any damage or defects. DO NOT use any Hose Assembly that displays any signs of nonconformance.

3.7 Minimum Bend Radius: Installation of a Hose at less than the minimum listed bend radius may significantly reduce the Hose life. Particular attention must be given to preclude sharp bending at the Hose to Fitting juncture. Any bending during installation at less than the minimum bend radius must be avoided. If any Hose is kinked during installation, the Hose must be discarded.

3.8 Twist Angle and Orientation: Hose Assembly installation must be such that relative motion of machine components does not produce twisting.

3.9 Securement: In many applications, it may be necessary to restrain, protect, or guide the Hose to protect it from damage by unnecessary flexing, pressure surges, and contact with other mechanical components. Care must be taken to insure such restraints do not introduce additional stress or wear points.

3.10 Proper Connection of Ports: Proper physical installation of the Hose Assembly requires a correctly installed port connection insuring that no twist or torque is transferred to the Hose when the Fittings are being tightened or otherwise during use.

3.11 External Damage: Proper installation is not complete without insuring that tensile loads, side loads, kinking, flattening, potential abrasion, thread damage or damage to sealing surfaces are corrected or eliminated. See instruction 2.10.

3.12 System Checkout: All air entrapment must be eliminated and the system pressurized to the maximum system pressure (at or below the Hose maximum working pressure) and checked for proper function and freedom from leaks. Personnel must stay out of potential hazardous areas while testing and using.

3.13 Routing: The Hose Assembly should be routed in such a manner so if a failure does occur, the escaping media will not cause personal injury or property damage. In addition, if fluid media comes in contact with hot surfaces, open flame or sparks, a fire or explosion may occur. See section 2.4.

3.14 Ground Fault Equipment Protection Devices (GFEPDs):

WARNING! Fire and Shock Hazard. To minimize the danger of fire if the heating cable of a Multitube bundle is damaged or improperly installed, use a Ground Fault Equipment Protection Device. Electrical fault currents may be insufficient to trip a conventional circuit breaker.

For ground fault protection, the IEEE 515: (www.ansi.org) standard for heating cables recommends the use of GFEPDs with a nominal 30 milliampere trip level for "piping systems in classified areas, those areas requiring a high degree of maintenance, or which may be exposed to physical abuse or corrosive atmospheres".

4.0 TUBE AND FITTINGS ASSEMBLY AND INSTALLATION INSTRUCTIONS

4.1 Component Inspection: Prior to assembly, a careful examination of the Tube and Fittings must be performed. All components must be checked for correct style, size, material, seal, and length. Inspect the Fitting and sealing surfaces for burrs, nicks, corrosion, missing seal or other imperfections. Do NOT use any component that displays any signs of nonconformance.

4.2 Tube and Fitting Assembly: Do not assemble a Parker Fitting with a Tube that is not specifically listed by Parker for that Fitting, unless authorized in writing by the engineering manager or chief engineer of the appropriate Parker division. The Tube must meet the requirements specified to the Fitting. The Parker published instructions must be followed for assembling the Fittings to a Tube. These instructions are provided in the Parker Fitting catalog for the specific Parker Fitting being used, or by calling 1-800-CPARKER, or at www.parker.com.

4.3 Related Accessories: Do not preset or flange Parker Fitting components using another manufacturer's equipment or procedures unless authorized in writing by the engineering manager or chief engineer of the appropriate Parker division. Tube, Fitting component and tool

Parker Safety Guide (Continued)

ing must be checked for correct style, size and material. Operation and maintenance of Related Accessories must be in accordance with the operation manual for the designated Accessory.

4.4 Securement: In many applications, it may be necessary to restrain, protect, or guide the Tube to protect it from damage by unnecessary flexing, pressure surges, vibration, and contact with other mechanical components. Care must be taken to insure such restraints do not introduce additional stress or wear points.

4.5 Proper Connection of Ports: Proper physical installation of the Tube Assembly requires a correctly installed port connection insuring that no torque is transferred to the Tube when the Fittings are being tightened or otherwise during use.

4.6 External Damage: Proper installation is not complete without insuring that tensile loads, side loads, flattening, potential abrasion, thread damage or damage to sealing surfaces are corrected or eliminated. See instruction 2.10.

4.7 System Checkout: All air entrapment must be eliminated and the system pressurized to the maximum system pressure (at or below the Tube Assembly maximum working pressure) and checked for proper function and freedom from leaks. Personnel must stay out of potential hazardous areas while testing and using.

4.8 Routing: The Tube Assembly should be routed in such a manner so if a failure does occur, the escaping media will not cause personal injury or property damage. In addition, if fluid media comes in contact with hot surfaces, open flame or sparks, a fire or explosion may occur. See section 2.4.

5.0 HOSE AND FITTING MAINTENANCE AND REPLACEMENT INSTRUCTIONS

5.1 Even with proper selection and installation, Hose life may be significantly reduced without a continuing maintenance program. The severity of the application, risk potential from a possible Hose failure, and experience with any Hose failures in the application or in similar applications should determine the frequency of the inspection and the replacement for the Products so that Products are replaced before any failure occurs. Certain products require maintenance and inspection per industry requirements. Failure to adhere to these requirements may lead to premature failure. A maintenance program must be established and followed by the user and, at minimum, must include instructions 5.2 through 5.7

5.2 Visual Inspection Hose/Fitting: Any of the following conditions require immediate shut down and replacement of the Hose Assembly:

- Fitting slippage on Hose;
- Damaged, cracked, cut or abraded cover (any reinforcement exposed);
- Hard, stiff, heat cracked, or charred Hose;
- Cracked, damaged, or badly corroded Fittings;
- Leaks at Fitting or in Hose;
- Kinked, crushed, flattened or twisted Hose; and
- Blistered, soft, degraded, or loose cover.

5.3 Visual Inspection All Other: The following items must be tightened, repaired, corrected or replaced as required:

- Leaking port conditions;
- Excess dirt buildup;/
- Worn clamps, guards or shields; and
- System fluid level, fluid type, and any air entrapment.

5.4 Functional Test: Operate the system at maximum operating pressure and check for possible malfunctions and leaks. Personnel must avoid potential hazardous areas while testing and using the system. See section 2.2.

5.5 Replacement Intervals: Hose assemblies and elastomeric seals used on Hose Fittings and adapters will eventually age, harden, wear and deteriorate under thermal cycling and compression set. Hose Assemblies and elastomeric seals should be inspected and replaced at specific replacement intervals, based on previous service life, government or industry recommendations, or when failures could result in unacceptable downtime, damage, or injury risk. See section 1.2. Hose and Fittings may be subjected to internal mechanical and/or chemical wear from the conveying fluid and may fail without warning. The user must determine the product life under such circumstances by testing. Also see section 2.5.

5.6 Hose Inspection and Failure: Hydraulic power is accomplished by utilizing high pressure fluids to transfer energy and do work. Hoses, Fittings and Hose Assemblies all contribute to this by transmitting fluids at high pressures. Fluids under pressure can be dangerous and potentially lethal and, therefore, extreme caution must be exercised when working with fluids under pressure and handling the Hoses transporting the fluids. From time to time, Hose Assemblies will fail if they are not replaced at proper time intervals. Usually these failures are the result of some form of misapplication, abuse, wear or failure to perform proper maintenance. When Hoses fail, generally the high pressure fluids inside escape in a stream which may or may not be visible to the user. Under no circumstances should the user attempt to locate the leak by "feeling" with their hands or any other part of their body. High pressure fluids can and will penetrate the skin and cause severe tissue damage and possibly loss of limb. Even seemingly minor hydraulic fluid injection injuries must be treated immediately by a physician with knowledge of the tissue damaging properties of hydraulic fluid.

If a Hose failure occurs, immediately shut down the equipment and leave the area until pressure has been completely released from the Hose Assembly. Simply shutting down the hydraulic pump may or may not eliminate the pressure in the Hose Assembly. Many times check valves, etc., are employed in a system and can cause pressure to remain in a Hose Assembly even when pumps or equipment are not operating. Tiny holes in the Hose, commonly known as pinholes, can eject small, dangerously powerful but hard to see streams of hydraulic fluid. It may take several minutes or even hours for the pressure to be relieved so that the Hose Assembly may be examined safely.

Once the pressure has been reduced to zero, the Hose Assembly may be taken off the equipment and examined. It must always be replaced if a failure has occurred. Never attempt to patch or repair a Hose Assembly that has failed. Consult the nearest Parker distributor or the appropriate Parker division for Hose Assembly replacement information. Never touch or examine a failed Hose Assembly unless it is obvious that the Hose no longer contains fluid under pressure. The high pressure fluid is extremely dangerous and can cause serious and potentially fatal injury.

5.7 Elastomeric Seals: Elastomeric seals will eventually age, harden, wear and deteriorate under thermal cycling and compression set. Elastomeric seals should be inspected and replaced.

5.8 Refrigerant Gases: Special care should be taken when working with refrigeration systems. Sudden escape of refrigerant gases can cause blindness if the escaping gases contact the eye and can cause freezing or other severe injuries if it contacts any other portion of the body.

5.9 Compressed Natural Gas (CNG): Parker CNG Hose Assemblies should be tested after installation and before use, and at least on a monthly basis per instructions provided on the Hose Assembly tag. The recommended procedure is to pressurize the Hose and check for leaks and to visually inspect the Hose for damage and to perform an electrical resistance test.

Caution: Matches, candles, open flame or other sources of ignition shall not be used for Hose inspection. Leak check solutions should be rinsed off after use.

6.0 HOSE STORAGE

6.1 Age Control: Hose and Hose Assemblies must be stored in a manner that facilitates age control and first-in and first-out usage based on manufacturing date of the Hose and Hose Assemblies. Unless otherwise specified by the manufacturer or defined by local laws and regulations:

6.1.1 The shelf life of rubber hose in bulk form or hose made from two or more materials is 28 quarters (7 years) from the date of manufacture, with an extension of 12 quarters (3 years), if stored in accordance with ISO 2230;

6.1.2 The shelf life of thermoplastic and polytetrafluoroethylene hose is considered to be unlimited;

6.1.3 Hose assemblies that pass visual inspection and proof test shall not be stored for longer than 2 years.

6.1.4 Storage: Stored Hose and Hose Assemblies must not be subjected to damage that could reduce their expected service life and must be placed in a cool, dark and dry area with the ends capped. Stored Hose and Hose Assemblies must not be exposed to temperature extremes, ozone, oils, corrosive liquids or fumes, solvents, high humidity, rodents, insects, ultraviolet light, electromagnetic fields or radioactive materials.



Parker Hannifin Corporation
Hydraulic Valve Division
520 Ternes Avenue
Elyria, Ohio 44035 USA
Tel: 440 366 5100
Fax: 440 366 5253
www.parker.com/hydraulicvalve